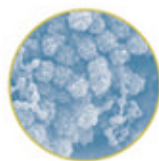




# Microbial Ecology



LARRY L. BARTON • DIANA E. NORTHUP

 WILEY-BLACKWELL



# MICROBIAL ECOLOGY







---

# MICROBIAL ECOLOGY

Larry L. Barton and Diana E. Northup

 **WILEY-BLACKWELL**

A JOHN WILEY & SONS, INC., PUBLICATION



Copyright © 2011 by Wiley-Blackwell. All rights reserved.

Published by John Wiley & Sons, Inc., Hoboken, New Jersey  
Published simultaneously in Canada

Wiley-Blackwell is an imprint of John Wiley & Sons, formed by the merger  
of Wiley's global Scientific, Technical and Medical business with Blackwell Publishing.

No part of this publication may be reproduced, stored in a retrieval system, or transmitted in any form or by any means, electronic, mechanical, photocopying, recording, scanning, or otherwise, except as permitted under Section 107 or 108 of the 1976 United States Copyright Act, without either the prior written permission of the Publisher, or authorization through payment of the appropriate per-copy fee to the Copyright Clearance Center, Inc., 222 Rosewood Drive, Danvers, MA 01923, (978) 750-8400, fax (978) 750-4470, or on the web at [www.copyright.com](http://www.copyright.com). Requests to the Publisher for permission should be addressed to the Permissions Department, John Wiley & Sons, Inc., 111 River Street, Hoboken, NJ 07030, (201) 748-6011, fax (201) 748-6008, or online at <http://www.wiley.com/go/permission>.

**Limit of Liability/Disclaimer of Warranty:** While the publisher and author have used their best efforts in preparing this book, they make no representations or warranties with respect to the accuracy or completeness of the contents of this book and specifically disclaim any implied warranties of merchantability or fitness for a particular purpose. No warranty may be created or extended by sales representatives or written sales materials. The advice and strategies contained herein may not be suitable for your situation. You should consult with a professional where appropriate. Neither the publisher nor author shall be liable for any loss of profit or any other commercial damages, including but not limited to special, incidental, consequential, or other damages.

For general information on our other products and services or for technical support, please contact our Customer Care Department within the United States at (800) 762-2974, outside the United States at (317) 572-3993 or fax (317) 572-4002.

Wiley also publishes its books in a variety of electronic formats. Some content that appears in print may not be available in electronic formats. For more information about Wiley products, visit our web site at [www.wiley.com](http://www.wiley.com).

***Library of Congress Cataloging-in-Publication Data:***

Barton, Larry, 1940-  
Microbial ecology / Larry L. Barton and Diana E. Northrup.  
p. cm.  
Includes index.  
ISBN 978-0-470-04817-7 (hardback)  
1. Microbial ecology. I. Northrup, Diana E. II. Title.  
QR100.B37 2011  
579'.17—dc22

2010043470

Printed in the United States of America

oBook ISBN: 978-1-118-01584-1  
ePDF ISBN: 978-1-118-01582-7  
ePUB ISBN: 978-1-118-01583-4

10 9 8 7 6 5 4 3 2 1

*Dedicated to  
Sandra, Kenneth,  
and the many students who  
inspired us to write this book*



---

# CONTENTS

---

<b>PREFACE</b>	<b>xvii</b>
<b>GLOSSARY</b>	<b>xix</b>
<b>1 MICROBIAL ECOLOGY: BEGINNINGS AND THE ROAD FORWARD</b>	<b>1</b>
1.1 Central Themes	1
1.2 Introduction	2
1.2.1 Roots of Microbial Ecology	3
1.2.2 Current Perspectives	4
1.3 Timeline	5
1.4 Microfossils	7
1.5 Early Life	9
1.5.1 The Precellular World	9
1.5.2 The First Cell	10
1.5.3 Development of Cellular Biology	11
1.5.4 Evolution of Metabolic Pathways	12
1.6 Characteristics of Microbial Life	13
1.6.1 Structure and Evolution of Cell Shape	13
1.6.2 Metabolism and Use of Energy	16
1.6.3 Growth, Reproduction, and Development	17
1.6.4 Adaptations and Response to Stimuli	18
1.7 Classification and Taxonomy: The Species Concept	18
1.8 The Three Domains: Tree of Life	19
1.9 Relationship of Microbial Ecology to General Ecology	22
1.10 Changing Face of Microbial Ecology	23
1.10.1 Change in Focus	23
1.10.2 Diversity: From Culturing to Molecular Phylogeny	24
1.11 Summary	25
1.12 Delving Deeper: Critical Thinking Questions	26
Bibliographic Material	26

<b>2</b>	<b>DIVERSITY OF MICROORGANISMS</b>	<b>29</b>
2.1	Central Themes	29
2.2	The Ubiquity of Microorganisms	29
2.3	The Amazing Diversity of Morphologies	30
2.3.1	Comparison of the Three Domains	32
2.3.2	What's in a Name: Prokaryotes	32
2.3.3	Winogradsky's Experiments with Chemolithotrophs	32
2.4	Diversity of Bacterial Groups	33
2.4.1	Expansion of the Number of Bacterial Phyla	33
2.4.2	Bacterial Portrait Gallery: Processes and Players	35
2.5	Discovery of Archaea as a Separate Domain	38
2.6	Archaeal Diversity	39
2.6.1	Archaeal Portrait Gallery	39
2.7	Archaea–Bacteria Differences	45
2.8	Eukarya: A Changing Picture of Phylogenetic Diversity	46
2.9	Protist Diversity	46
2.9.1	Protist Gallery	49
2.10	Fungal Diversity	51
2.11	Algal Diversity	54
2.12	Viral Diversity	56
2.13	Summary	57
2.14	Delving Deeper: Critical Thinking Questions	58
	Bibliographic Material	58
<b>3</b>	<b>COMPLEXITY AND SIMPLICITY OF CELL SYSTEMS</b>	<b>61</b>
3.1	Central Themes	61
3.2	Introduction	62
3.3	Cell Parameters	63
3.3.1	Life at the Lowest Level	64
3.3.2	Large Microorganisms	66
3.4	Cell Movement and Chemotaxis	68
3.5	Structures of Sporulation	71
3.6	Nutrient Reserves and Storage Materials	74
3.7	Cell–Cell Associations	75
3.7.1	Cell Attachment	76
3.7.2	Biofilms	78
3.7.3	Filamentous Growth	82
3.8	Cell Physiology and Metabolism	84
3.8.1	Sensory Response	84
3.8.2	Global Regulation	86

3.8.3	Internal Membranes in Bacteria	87
3.9	Energetics and Environment	88
3.9.1	Heterotrophs	88
3.9.2	Chemolithotrophs	91
3.9.3	Photophosphorylation	94
3.9.4	Bacteriorhodopsin Reaction	94
3.10	Bioelectrochemical Activities	97
3.11	Summary	99
3.12	Delving Deeper: Critical Thinking Questions	100
	Bibliographic Material	100
<b>4</b>	<b>THE MICROBIAL HABITAT: AN ECOLOGICAL PERSPECTIVE</b>	<b>103</b>
4.1	Central Themes	103
4.2	Habitats: An Overview	104
4.2.1	The Niche	105
4.3	Aquatic Habitats	105
4.3.1	Freshwater	107
4.3.2	Marine Habitats	110
4.4	Soil Habitats	111
4.4.1	Microbial Food Webs in the Soil Habitat	112
4.5	Rock and Subsurface Habitats	117
4.5.1	Rock Varnish	117
4.5.2	Cave Habitats	119
4.5.3	Groundwater	120
4.5.4	Deep Subsurface	120
4.6	Atmospheric Habitats	121
4.6.1	Atmospheric Microbial Diversity: African Dust	121
4.6.2	Mysteries Remain	122
4.7	Population Ecology Across Habitats	124
4.7.1	Population Growth and Dynamics	124
4.7.2	Horizontal Gene Transfer	125
4.7.3	Biogeography versus Everything is Everywhere; the Environment Selects	126
4.8	Summary	128
4.9	Delving Deeper: Critical Thinking Questions	129
	Bibliographic Material	129
<b>5</b>	<b>THE HOW OF MICROBIAL ECOLOGY STUDIES</b>	<b>131</b>
5.1	Central Themes	131
5.2	Introduction	132
5.3	Sampling and Sample Storage	134

5.4	Microscopy	135
5.4.1	Gram Stains	135
5.4.2	Direct Count Procedures	135
5.4.3	Determining Actively Respiring Cells	136
5.4.4	Fluorescent <i>in situ</i> Hybridization (FISH)	137
5.4.5	Electron Microscopy	139
5.5	Cultivation of Microorganisms	139
5.5.1	Microbial Respiration	144
5.5.2	Microbial Biomass	144
5.5.3	Measuring Carbon Substrate Utilization	145
5.6	Molecular Phylogenetics	146
5.7	Culturing Versus Molecular Techniques: Comparisons from Soil Studies	148
5.8	Community Fingerprinting Methods	149
5.8.1	Denaturing Gradient Gel Electrophoresis	149
5.9	Metagenomics: A New Tool for Answering Community Ecology Questions	149
5.10	Environmental Proteomics	150
5.11	Stable-Isotope Studies	152
5.11.1	Using Stable Isotopes: Movile Cave Food Web Case Study	153
5.12	Summary	154
5.13	Delving Deeper: Critical Thinking Questions	155
	Bibliographic Sources	155

## **6 MICROBE–MICROBE INTERACTIONS 159**

6.1	Central Themes	159
6.2	Introduction	160
6.3	Classification of Microbial Interactions	161
6.3.1	Neutralism	162
6.3.2	Commensalism	162
6.3.3	Competition	162
6.3.4	Parasitism	163
6.3.5	Predation	164
6.3.6	Antagonism (Amensalism)	164
6.3.7	Syntrophism	167
6.4	Symbiotic Associations	168
6.4.1	Diatoms	168
6.4.2	Lichen	169
6.4.3	Hatena	171
6.4.4	Symbiosis between Bacteria and Protozoa	173



6.5	Fungus–Bacterium Symbiosis	174
6.6	Prokaryote–Prokaryote Interactions	174
6.6.1	Two-Member Mutualism	174
6.6.2	Examples of Parasites and Predators	174
6.7	Establishing a Symbiosis: The Nostoc–Geosiphon Association	176
6.8	Sexual Interactions	176
6.9	Summary	178
6.10	Delving Deeper: Critical Thinking Questions	180
	Bibliographic Material	181

## **7 INTERACTIONS BETWEEN MICROORGANISMS AND PLANTS 183**

7.1	Central Themes	183
7.2	Introduction	184
7.3	Symbiotic Associations with Cyanobacteria	186
7.4	Interactions in the Rhizosphere	187
7.5	Mycorrhizae	189
7.5.1	Ectomycorrhizae	190
7.5.2	Endomycorrhizae	193
7.5.3	Other Mycorrhizal Associations	193
7.6	Nitrogen-Fixing Bacteria and Higher Plants	195
7.6.1	Root Associations	195
7.6.2	Stem Associations	202
7.7	Bacteria Supporting Plant Growth	202
7.7.1	Production of Hormones	202
7.7.2	Growth-Promoting Rhizobacteria	202
7.7.3	Cactus Symbiosis	204
7.8	Leaf Surfaces and Microorganisms	205
7.9	Detrimental Activities of Microorganisms on Plants	206
7.9.1	Fungal Parasites	206
7.9.2	Bacterial Pathogens	207
7.9.3	Rhizosphere Activities and Plant Diseases	209
7.10	Fungi Promoting Increased Heat Tolerance in Plants	211
7.11	Biocontrol of Pests and Pathogens	211
7.12	Summary	214
7.13	Delving Deeper: Critical Thinking Questions	214
	Bibliographic Material	215

## **8 INTERACTIONS BETWEEN MICROORGANISMS AND ANIMALS 217**

8.1	Central Themes	217
8.2	Introduction	218

8.3	Primary and Secondary Symbionts	222
8.4	Microbe–Animal Interactions: Parasitism	223
8.4.1	Parasitism Introduction	223
8.4.2	Nematode Parasitism of Insects	223
8.4.3	Effects of Multiple Parasitic Infections on Virulence	224
8.4.4	A Widespread Endosymbiosis: <i>Wolbachia</i> — Parasitism or Mutualism?	224
8.5	Microbe–Animal Interactions: Mutualism	225
8.5.1	Gut Animal–Microbe Mutualistic Interactions	225
8.5.2	Case Study: Unique Bacterial–Polychaete Endosymbiosis	227
8.5.3	Case Study: Beetles Cultivating Fungal Gardens	228
8.5.4	Mealybug Mutualisms	229
8.5.5	Luminescent Bacteria in Fish and Squid: Turning on the Lights	230
8.6	Lessons from the Deep: Evolutionary and Ecosystem Insights from Deep-Sea Vents Symbioses	230
8.7	Microbial–Vertebrate Interactions	233
8.7.1	Bacteria and Birds	235
8.7.2	Microorganisms and Humans	236
8.8	Grazing and Predation by Animals	236
8.9	Summary	239
8.10	Delving Deeper: Critical Thinking Questions	239
	Bibliographic Material	240

## **9 LIVING TOGETHER: MICROBIAL COMMUNITIES 243**

9.1	Central Themes	243
9.2	Introduction	244
9.2.1	Dominant Issues and Questions in Microbial Community Ecology	245
9.3	Metagenomics: A New Tool for Answering Community Ecology Questions	246
9.4	Biomats and Biofilms	247
9.4.1	Changes in Community Structure during Biofilm Succession	249
9.5	Formation of Organized Communities: Quorum Sensing	249
9.6	Colonization and Recolonization by Microorganisms	251
9.6.1	Case Study: Colonization of the Sterile Newborn Gut	252
9.6.2	Case Study: Undesirable Colonization—Factors in Disease	253
9.6.3	Case Study: Recolonization and Early Succession in Intertidal Sediments	253
9.7	Dispersal, Succession, and Stability	253

9.7.1	Case Study: Dispersal and Succession in the Oceans— Whale Falls as Dispersal Agents between Vents	254
9.7.2	Competition as a Structuring Force in Succession	254
9.7.3	Stability in Microcosm Studies	255
9.8	Species Diversity	256
9.8.1	Diversity Indices	257
9.8.2	Connections between Metazoans and Microorganisms: Co-occurrence Patterns	258
9.8.3	Disturbance and Diversity	258
9.9	Food Webs	259
9.9.1	Structure of Microbial Food Webs	260
9.9.2	Keystone Species Effects on Food Webs and Diversity	261
9.10	Primary Production and Energy Flow	261
9.10.1	Cycling of Nutrients	261
9.11	Microbial Community Examples	262
9.11.1	Plankton in Marine Ecosystems	263
9.11.2	Hot Springs	264
9.11.3	Wine and Cheese	266
9.12	Summary	269
9.13	Delving Deeper: Critical Thinking Questions	270
	Bibliographic Material	270

## **10 MICROBIAL PROCESSES CONTRIBUTING TO BIOGEOCHEMICAL CYCLES** **273**

10.1	Central Themes	273
10.2	Introduction	274
10.3	Energy Flow	276
10.4	Oxygen and Carbon Cycling	278
10.5	Nitrogen Cycling	281
10.5.1	Nitrogen Fixation	282
10.5.2	Nitrogen Assimilation	283
10.5.3	Nitrification	283
10.5.4	Denitrification	284
10.6	Sulfur Cycling	284
10.6.1	Organic Sulfur Metabolism	285
10.6.2	Inorganic Sulfur Metabolism	285
10.7	Phosphorus Cycling	286
10.8	Iron Cycling	287
10.8.1	Siderophores	288
10.8.2	Ferritin and Magnetosomes	289

10.9	Cycling of Manganese and Selenium	290
10.10	Cycling of Hydrogen	293
10.11	Transformation of Mercury	294
10.12	Closed Systems	295
10.13	Summary	296
10.14	Delving Deeper: Critical Thinking Questions	297
	Bibliographic Material	297

## **11 MICROBES AT WORK IN NATURE: BIOMINERALIZATION AND MICROBIAL WEATHERING 299**

11.1	Central Themes	299
11.2	Introduction	300
	11.2.1 Passive versus Active Biomineralization	302
11.3	Cell Characteristics and Metal Binding	303
	11.3.1 Passive Metal Adsorption	303
	11.3.2 Active Metal Adsorption	303
11.4	Energy Flow: Shuffling Electrons; Redox Reactions	304
11.5	Dissolution Versus Precipitation	305
11.6	Formation of Ores and Minerals	306
	11.6.1 Biomining	307
	11.6.2 Recovery of Petroleum	307
	11.6.3 Sulfuric Acid–Driven Speleogenesis	310
11.7	Microbial Participation in Silicification	312
	11.7.1 Silica Formation in Diatoms, Radiolarians, and Sponges	312
	11.7.2 Geysers	313
11.8	Biomineralization of Ferromanganese Deposits	314
	11.8.1 Magnetite Formation	314
	11.8.2 Rock Varnish	315
11.9	Microbial Carbonate Microbialites	317
11.10	Stromatolites	319
	11.10.1 Thrombolites	320
	11.10.2 Travertines and Tufas	321
	11.10.3 Coccolithophores and Foraminifera: Biologically Controlled Mineralization	323
11.11	Summary	324
11.12	Delving Deeper: Critical Thinking Questions	324
	Bibliographic Material	325

## **12 DECOMPOSITION OF NATURAL COMPOUNDS 327**

12.1	Central Themes	327
12.2	Introduction	328

12.3	Decomposition of Wood	329
12.4	Digestion of Plant Cell Wall Structures	331
	12.4.1 Protopectinase and Pectinase Activities	333
	12.4.2 Microbial Decomposition of Lignin	333
	12.4.3 Degradation of Hemicellulose	334
	12.4.4 Enzymatic Degradation of Cellulose	335
12.5	Starch Hydrolysis	336
12.6	Inulin Hydrolysis	336
12.7	Decomposition of Diverse Biopolymers Including Animal Fibrous Proteins	337
	12.7.1 Chitin Digestion	337
	12.7.2 Decomposition of Keratin	337
	12.7.3 Fibroin Decomposition	338
	12.7.4 Collagen Breakdown	339
12.8	Ecology of Fermented Foods	341
12.9	Ecology of Bioenergy Production	343
	12.9.1 Alcohol Production	345
	12.9.2 H <sub>2</sub> Production	346
	12.9.3 Methane Production	347
	12.9.4 Biodiesel Production by Algae	348
12.10	Waste Treatment Systems	349
12.11	Composting of Plant Organic Matter	350
12.12	Impact of Microbial Degradation on Humans	352
12.13	Summary	354
12.14	Delving Deeper: Critical Thinking Questions	355
	Bibliographic Material	355

## **13 MICROBES AT WORK: BIOREMEDIATION** **359**

13.1	Central Themes	359
13.2	Introduction	360
13.3	Bioremediation as a Technology	361
13.4	Genetic Engineering	362
13.5	Design and Implementation of Bioremediation	362
	13.5.1 Bioreactors	362
	13.5.2 Biofarming	363
	13.5.3 Permeable Reactive Barriers	363
	13.5.4 Optimizing Bioremediation	363
13.6	Bioremediation of Organic Compounds	365
13.7	Degradation of Hydrocarbons	365
	13.7.1 Oil Spills	366
	13.7.2 Methane Utilization	366

13.7.3	Fuel Hydrocarbons	368
13.7.4	Polyaromatic Hydrocarbons	372
13.8	Degradation of Xenobiotics	373
13.8.1	Detoxification of Chlorinated Organic Compounds	375
13.8.2	Herbicides and Pesticides	376
13.8.3	Biodegradation of Explosives	377
13.8.4	Decomposition of Textile Dyes	378
13.9	Bioremediation with Inorganic Pollutants	380
13.9.1	Microbe–Toxic Metal Interactions	381
13.9.2	Detoxification of Selenium	384
13.9.3	Reactions with Arsenic	385
13.9.4	Bioremediation of Perchlorate Sites	387
13.9.5	Bioremediation of Nitrate Pollution	387
13.10	Summary	389
13.11	Delving Deeper: Critical Thinking Questions	390
	Bibliographic Material	390

**INDEX****395**

---

# PREFACE

---

This book was written with the objective of including it as a central part of a higher-education program that offers a semester course in microbial ecology. This book is appropriate for upper-level undergraduate or graduate students pursuing majors in biology, microbiology, ecology, or environmental science. In our presentation, we have assumed that students have backgrounds in chemistry, biology, and microbiology. Our approach is to present basic principles, provide an insight into relevant methodologies, and discuss interactions that are characteristic of microorganisms. We have used an integrative approach to relate new topics that are addressed in the book to the broader scientific field. As an outgrowth of our teaching numerous courses of microbiology, we understand the importance of providing specifics for different topics and, therefore, have included many examples associated with microbial ecology. We broadly cover the environments where microorganisms are found and include community activities in processes that are important in commercial and environmental events. Since this book is designed for use in teaching, each chapter contains a summary, bibliographic sources for additional reading, and review questions appropriate for class discussion. Numerous bibliographic references are cited throughout the text to provide access to additional information on topics covered. It is our hope that this book will stimulate the study of microbial ecology and development of new approaches to evaluate microbes in a natural setting.

We provide an overview of the field of microbial ecology, and while we focus on bacteria, we include numerous examples of other microorganisms. Chapter 1 provides a perspective on historical developments and more recent activities of microbial ecology. The diversity of the organisms in the “tree of life” and the distinctions between *Archaea* and *Bacteria* are covered in Chapter 2. To assist in the understanding of cellular processes for specific environments, Chapter 3 covers the structural, physiological, and metabolic characteristics of microorganisms. The ubiquity of microorganisms in various habitats and techniques for studying them are the topics of Chapters 4 and 5, respectively. Microbe–microbe interactions, including dominance in a population, are discussed in Chapter 6. Plant–microbial interactions are relatively unique, and features of these activities are discussed in Chapter 7. To illustrate the many different interactions between microorganisms and animals, we have provided information on several of these in Chapter 8. Community structure, colonization activities, and species diversity are covered in Chapter 9. Microorganisms are important in several of the major nutrient cycles, and in Chapter 10 we cover the influence of microorganisms on biogeochemical cycles. Since microorganisms may have considerable impact on the environment, we have designated Chapter 11 as a summary of the activities of biomineralization and microbial weathering. The beneficial activities of natural polymer decomposition and use of microbes in bioenergy production are discussed in Chapter 12. The final

chapter, Chapter 13, discusses the participation of microorganisms in various types of bioremediation and processes to achieve microbial detoxification of the environment.

We appreciate the support of our colleagues and friends who have contributed to this book. Most of the photographs and other images used in this text are original and were provided by many scientists working in microbial ecology. We also acknowledge these scientists for providing highlights of their microbial ecology activities, biographic and these sketches are presented in the chapters as microbial “spotlight” events. Selection of individuals for spotlights was based on our desire to cover a diversity of areas of microbial ecology, and we wish that we had more space to include additional spotlights. We gratefully acknowledge these contributors as follows:

- **Photographs provided by**

Esther Angert  
 Sue Barns  
 Sandra Barton  
 Dennis Bazylinski  
 Rebecca Bixby  
 Cliff Dahm  
 Airidas Dapkevicius  
 Armand Dichosa  
 Martin Dworkin  
 Jane Gillespie  
 Girhsorn  
 Dale Griffin  
 G. Hirson  
 Kenneth Ingham  
 Gordon Johnson  
 Brian Jones  
 Peter Jones  
 Leslie Melim  
 Yauoi Nishiyama  
 T.C. Onstott  
 Robin Renaut  
 Adam W. Rollins

Janet Shagam  
 Holly Simon  
 David Scott Simonton  
 Jessica Snider  
 Michael Spilde  
 Helga Stan-Lotter  
 Ward’s Natural Science  
 John Waterbury

- **Microbial spotlights provided by**

Dominique Expert  
 Gill Geesey  
 Dale Griffin  
 Jared Leadbetter  
 Lynn Margulis  
 David Mills  
 Michael O’Connell  
 T.C. Onstott  
 Norman Pace  
 Anna-Louise Reysenbach  
 Mitch Sogin  
 Joseph Sufleta  
 Brad Tebo  
 Lily Young

We are most appreciative of the assistance, patience, and professional contributions of Karen Chambers and the editorial staff at John Wiley.

LARRY L. BARTON  
 DIANA E. NORTHUP



---

# GLOSSARY

---

- actinomycete** A group of chemoorganotrophic soil bacteria that may grow as filaments and display branching.
- adhesins** Microbial surface antigens, often in the form of filamentous pili or proteins, that bind one cell to another.
- air stripping** The injection of air into soil with the purpose of carrying volatile materials into the atmosphere.
- alkane** Referring to saturated hydrocarbons with carbon atoms in a chain without double bonds.
- alkene** Referring to unsaturated hydrocarbons with carbon atoms in a chain containing double bonds between the carbon atoms.
- allelopathy** Inhibition of growth of one species by another species by production of secondary metabolites known as *allelochemicals*. Commonly allelopathy is associated with plants but in a broad sense may be associated with microorganisms and coral.
- amensalism** The state of one microorganism having a negative effect on another microorganism.
- anaerobic microorganisms** Bacteria, archaea, or yeast growing in the absence of oxygen.
- anammox reaction** A bacterial reaction involving the anaerobic oxidation of ammonium with reduction of nitrite to produce N<sub>2</sub>.
- anoxygenic** Referring to activity that contributes to the anaerobic environment.
- antagonism** The state of one organism inhibiting the growth of another organism.
- anthropogenic** Referring to chemicals that result from human influence in contrast to chemicals resulting from natural processes.
- Arthropoda** Animals with exoskeletons, segmented bodies, and jointed appendages. They include *Acari*, arachnids that include mites and ticks; Annelida, segmented worms such as earthworms (Enchytraeida), and Nematoda, unsegmented worms (also termed *roundworms*).
- assimilation** The incorporation of compounds into cellular materials.
- augmentation** With respect to bioremediation, the addition of desired bacteria to a bioreactor or to a contaminated site.
- azo dyes** Brightly colored dyes used in the textile industry that contain the azo ( $-N=N-$ ) group.
- bacteriome** A specialized organelle in insects that hosts bacterial endosymbionts.
- bacteriophages** Viruses that attack bacteria.
- benthic** Referring to habitats at the bottom of aquatic environments.
- biodiesel** An extract of algal cells containing oils; suitable for use in engines.
- biofarming** The addition of contaminated soil to agricultural soil with the purpose of soil microorganisms mineralizing the organic contaminant.

- biofilm** Film containing microbial cells of diverse genera that are localized on a surface by extracellular matrix material.
- biofuel** A biological product (ethanol, methane, H<sub>2</sub>, etc.) that can be used as an engine fuel.
- biogeochemical cycle** The path that a nutrient or element takes as it moves through the biosphere, hydrosphere, lithosphere, and atmosphere.
- biogeography** The spatial distribution of organisms and the processes that bring about this distribution.
- biolomics** The study of all biological systems and biochemical components of a cellular system.
- biomineralization** The process by which microorganisms form mineral phases.
- biomining** The use of microorganisms to aid in the extraction and recovery of metals from ores.
- bioremediation** The application of microorganisms (or biological material) to detoxify organic substances or inorganic compounds.
- biosignatures** Characteristic morphologies or attributes, such as biominerals, found in rocks; reveal the presence of microorganisms in the past.
- bisorption** Metabolism-independent binding of metal ions or radionuclide species to cellular components.
- biosphere** An entity that includes all ecosystems of Earth.
- cellulose** A biopolymer that consists of several dozen chains of microfibrils where each chain of glucose is held by  $\beta$ -1,4-glycosidic bonds.
- cellulosome** The structure containing enzymes for cellulose digestion; may occur on the surface of some bacterial cells.
- chemoautotrophy** The process in which carbon dioxide is used as the source of carbon.
- chemolithotrophs** Microorganisms that couple electron flow to oxidation or reduction of inorganic materials.
- chemolithotrophy** The process in which inorganic compounds are oxidized to generate energy for organisms.
- chemoorganotrophs** Organisms that utilize organic compounds as their energy sources.
- chert** Microcrystalline quartz that may contain microfossils.
- codon** Three bases in RNA that code for a specific amino acid in the synthesis of proteins.
- coenocytic** Referring to multinucleated cells resulting from incomplete crosswalls as is the case with some fungi.
- colonization resistance** The ability of the host's gut to prevent colonization by nonnative microorganisms, due at least in part to the native microbiota's actions.
- commensalism** Situation in which one partner benefits, while the other neither benefits nor is harmed; in mutualism both partners benefit; and in parasitism one partner is harmed while the other benefits.
- community** An association of species that interact and live within a physical environment.
- community ecology** The study of interactions among species that live together in a defined physical area and the biogeography, abundance, and distribution of the coexisting populations.
- competition** Activity involving two or more microorganisms seeking the same niche or nutrients.

- compost** A process using aerobic microbial decomposition of plant material for the production of a soil conditioner.
- conjugation** The genetic exchange resulting from cell–cell contact; occurs in both prokaryotic and eukaryotic microorganisms.
- coprophilic** Referring to organisms that have a preference for growing on fecal material.
- creosote** A distillation of coal tar that contains polyaromatic hydrocarbons; has been used to preserve wood in poles and railroad ties.
- cryptomonad** A flagellated cell with a chloroplast that may be considered as a member of either algae or protozoa.
- cyanobionts** Intracellular or extracellular associations of cyanobacteria with diatoms.
- cyst** A resting cell produced by a few bacterial or protest species; this structure is less resistant than a bacterial endospore.
- dehydrogenase** An enzyme that oxidizes molecules by transferring electrons to an electron carrier of NAD or cytochromes.
- denitrification** The conversion of nitrate to atmospheric nitrogen.
- desert varnish** The darkened surface on rocks in desert environments, also called *rock varnish*.
- dinitrogen** Atmospheric nitrogen, N<sub>2</sub>.
- dissimilation** Activity leading to the conversion of an electron acceptor to a metabolic end product; not associated with incorporation of chemicals into cell biomass.
- dissimilatory reduction** In microbiology, the transfer of a large number of electrons to an electron acceptor with the consequence of producing a high quantity of product from respiration.
- dissimilatory sulfate reduction** The use of sulfate as the final electron acceptor by chemolithotrophic organisms with the production of H<sub>2</sub>S.
- disturbance** An event that causes the death, displacement, or harm of or to individuals within a given population, community, or ecosystem; leads to opportunities for new individuals to replace them.
- DMRB** Dissimilatory metal-reducing bacteria, in which electrons from an organic are passed to an oxidized metal ion.
- ecotype** A group of individuals (population or subspecies) that have adapted to a particular ecological niche in which they live, becoming genetically similar.
- endolithic** Referring to microorganisms that live within rock in the pore spaces.
- endospore** The most resistant biological structure; is produced by specific bacteria.
- epilimnion** The surface layer of lakes, which is warmer, less dense, and sunlit.
- epiphyte** A microorganism growing on the surface, usually leaves, of a plant.
- Eukarya** One of the three phylogenomic domains of the tree of life; contains all of the eukaryotes.
- eukaryote** A cell or organism that has a true nuclear nucleus and internal membranes and is a member of Eukarya.
- eutrophic habitats** Habitats that are nutrient-rich, potentially leading to eutrophication in which oxygen levels become very low and algal blooms occur.
- extracellular polymeric matrix (EPM)** Polysaccharide material surrounding bacterial cells along with other polymeric material.
- extremophiles** Organisms that live in and have adapted to extreme conditions of pH, temperature, or salinity.
- fermentation** An anaerobic metabolic process of bacteria and yeast resulting in the production of desired end products including ethanol and lactic acid.

- ferritin** A protein consisting of 24 subunits; used to store iron in the cytoplasm of animals and a few bacteria.
- filament** A cluster of cells arranged in a linear form.
- food chain** A representation of the flow of energy within a food web, from one level to the next, showing the sequence of what is eaten by what.
- food web** A system representing feeding relationships within a community and linkages among food chains.
- fruiting body** An asexual reproductive structure produced by soil fungi and a few bacteria.
- genetic engineering** Activity involving the transfer of desired genes into a microorganism for the purpose of exploiting the activity of the gene product.
- genomics** Study of the gene content of an organism.
- genotype** The gene content of an organism.
- glutathione** A peptide consisting of three amino acids (glycine, cysteine, and glutamate); functions to protect cells against various toxicities.
- Gram-negative/Gram-positive bacteria** Bacteria distinguished under a microscope by differential staining procedures. Generally Gram-negative bacteria have a more diverse metabolism and grow faster than do Gram-positive bacteria.
- guild** A group of species that share a common ecological niche.
- haustaria** Specialized branches extending from a parasitic fungal cell that may be extended into a host cell.
- hemicellulose** The material extracted from the cell walls of plants consisting of xylose–glucose polymers or glucose–arabinose–xylose polymers.
- herbicide** Chemical agents that are used to kill plants.
- heterocyst** A specialized cell that occurs in some filamentous cyanobacteria, providing oxygen-free environments in which nitrogen fixation can take place.
- heterotrophs** (Or chemoorganotrophs) organisms that use organic compounds as energy sources and to obtain carbon for cellular processes.
- hopanoids** Heterocyclic lipids found in the membranes of bacteria. The chemical structure is similar to that of sterols such as cholesterol.
- horizontal gene transfer** The movement of genes between different organisms rather than by vertical transmission during cell division.
- horizontal transmission** A process in which endosymbionts are transferred from one individual of the host species to another or even to other species.
- hydrogel** A substance in which the biofilm polymer is hydrated with water, forming a viscous jelly-like matrix.
- hydrogenase** An enzyme that cleaves molecular hydrogen to two protons and two electrons.
- hydrogenosomes** Organisms found in some anaerobic microbial eukaryotes; ferment pyruvate, yielding carbon dioxide, hydrogen, and acetate. Like mitochondria, hydrogenosomes generate energy in the form of ATP.
- hydrolytic reaction** An enzymatic process in which water is added across a covalent bond to produce monomeric units from a dimer or polymer.
- hyperthermophiles** Organisms that live above 80°C.
- hyphae** The thread-like web of fungal cells making up the mycelium (singular *hypha*).
- hypolimnion** The bottom layer of lakes, which is colder, more dense, and darker than the epilimnion.
- indigenous bacteria** Bacteria normally present in the environment.

- kerogen** A mixture of complex organic compounds of high molecular weight that are found in sedimentary rocks.
- lateral gene transfer** A term often applied to horizontal gene transfer.
- lignin** An amorphous polymer present in woody tissue that functions to secure the cellulose fibrils together.
- lyase** A class of enzyme that releases a small molecule from a large compound.
- magnetosomes** Magnetic structures found in cells of specific bacterial species.
- magnetotaxis** The ability of magnetotactic bacteria to align themselves and swim along magnetic field lines.
- manganese nodules** Rock-like deposits of manganese and other metals found on the sea floor.
- melanin** An organic molecule with a complex structure that is responsible for brown to black pigmentation.
- metabiomics** The study of small molecules and intermediate compounds produced from metabolism.
- metagenomics** The culture-independent whole-genome analysis of all members of a community of microorganisms to determine the composition and functions of the microorganisms.
- metallomics** The study of metal ions and their activities in a biological system.
- metallothionein** A cytoplasmic protein containing numerous cysteine residues that bind toxic metal ions; found in eukaryotic cells and a few cyanobacteria.
- metaproteomics** The analysis of all proteins present in a specific environment.
- methane hydrate** Also known as *methane clathrate*; ice-containing methane in a water crystal.
- methanobacteria** Bacteria that grow by obtaining energy from the oxidation of methane.
- methanotroph** A microorganism that grows with methane as the electron donor.
- methylobacteria** Bacteria that grow with methanol as the electron donor.
- micrite** Very fine-grained (1–5- $\mu\text{m}$ ) calcite crystals.
- microbialites** Microbially produced organosedimentary benthic deposits.
- microbially influenced corrosion (MIC)** Also termed biocorrosion; the process by which microorganisms deteriorate metal.
- microbiomics** The study of all microorganisms and their interactions in an environment.
- microfossils** Fossils that contain cyanobacteria or other microorganisms.
- microorganisms** Prokaryotic, eukaryotic, and other organisms that are microscopic in nature.
- mitosomes** Double-membrane sacs that contain clustered mitochondria-like proteins.
- mold** A general name for filamentous fungi.
- MTBE** Methyl-(*tert*)-tertiary butyl ether; a gasoline additive that increases the oxygen content of the fuel.
- mutualism** The state where both partners benefit from a relationship.
- mycelium** The entire mass resulting from aggregation of fungal hyphae.
- mycobiont** The fungal partner in a symbiotic relationship (e.g., fungi in lichen).
- nanobacteria** Organisms of a specific species that have a normal growing size of 0.2–0.4  $\mu\text{m}$ .
- neutralism** The state of two microorganisms growing in close proximity to each other without any effect (positive or negative) on the other.

- nitrification** The production of nitrate from nitrite or other reduced nitrogen compounds.
- nitrogen fixation** Also called *diazotrophy*; the process of reducing atmospheric nitrogen to ammonia, carried out by various bacteria and archaea in order to supply nitrogen for building proteins and nucleic acids.
- nitrogenase** The enzyme that converts atmospheric nitrogen to ammonia.
- nucleoid** The nuclear material in a prokaryotic organism.
- oligotrophic** Referring to habitats that are nutrient-poor and hence exhibit low productivity; a term often applied to low levels of organic carbon.
- oxygenase** An enzyme that incorporates molecular oxygen directly into a substrate.
- oxygenic** Referring to activity resulting in the generation of molecular oxygen.
- parasitism** The state of one organism benefiting at the expense of another organism.
- pectin** A mixture of branched heterogeneous polysaccharides containing galacturonic acid with the polysaccharide held in the cell wall by  $\text{Ca}^{2+}$ .
- pelagic** Term referring to habitats above the bottom of aquatic environments.
- pesticide** A chemical effective in killing unwanted agents in the environment.
- phenotype** The characteristics of an organism that are readily observed.
- pheromones** Low-molecular-weight compounds secreted by cells that are important for mating.
- phosphonate** A compound with phosphorus covalently linked to a carbon atom.
- photobiont** The photosynthetic partner in a symbiotic relationship.
- photosynthesis** A process in which solar energy is used to reduce carbon dioxide to carbohydrates.
- phototrophy** The type of metabolism in which energy from light is converted to chemical energy.
- phycobilin** Light-capturing molecules in red algae and cyanobacteria that transmit light energy to chlorophylls.
- phylogenetics** The study of relationships among organisms based on evolutionary differences and similarities.
- phytic acid** Common name for inositol hexaphosphate, a major storage phosphorus compound in plants.
- phytochelator** A cytoplasmic protein found in plant cells that contains several cysteine residues and binds toxic metal ions.
- phytoplankton** *Marine phytoplankton* include the microscopic algae and diatoms that float in the ocean and are responsible for the bulk of marine photosynthesis.
- picoplankton** Very small organisms ( $<2 \mu\text{m}$ ) that float free in the water column.
- pili** Linear structures of protein that extend from the surface of Gram-negative bacteria.
- planktonic organisms** Organisms that are not attached to surfaces.
- plasmid** DNA found in the cytoplasm of bacterial cells that provides the cell with special benefits.
- polyaromatic hydrocarbon** A water-insoluble molecule consisting of several ring structures.
- POP** Persistent organic pollutant.
- predation** The preying of one microorganism on another microorganism.
- prokaryote** A microorganism that does not have a true nucleus but in which DNA is distributed in the cell cytoplasm.
- proteomics** Study of the protein content of an organism.

- Redfield ratio** Our oceans show a ratio of 16–1 of nitrogen to phosphorus, which corresponds to the average ratio seen in marine phytoplankton; this is called the *Redfield ratio*.
- resilience** The ability of an ecosystem to return to its former state following a disturbance (derived from the Latin *resilire*, to rebound).
- rhizosphere** The area of soil surrounding plant roots.
- ribozyme** An RNA molecule with enzymatic activity.
- selenomethionine** An amino acid that has a selenium element substituting for sulfur in methionine.
- sensory systems** Systems consisting of a cascade of proteins that enable cells to respond to physical or chemical stimuli.
- siderophores** Small organic compounds produced by bacteria or fungi; these compounds facilitate cellular uptake of  $\text{Fe}^{3+}$ .
- silicalemma** The membrane of the silica deposition vesicle in diatoms.
- sludge** Solid material containing a high concentration of microorganisms, inorganic precipitates, and undigested organic solids.
- sorption** A term used to include adsorption and absorption; a process where a chemical moves from a soluble phase to an insoluble phase.
- species** A genus subdivision consisting of closely related organisms.
- stability** The ability of a community to return to its prior species composition, diversity, and abundance and to retain its genetic traits following a disturbance.
- stromatolite** The layered limestone structure developed in shallow water that results from inorganic precipitation. Some stromatolites contain fossilized microbes.
- succession** The replacement of one community by another over time.
- sulfureta** The zones in an aquatic environment where sulfur bacteria grow in association with sulfate-reducing bacteria (singular *sulfuretum*).
- symbiogenesis** A phenomenon that occurs when new physiological processes, tissues, or organs evolve as a result of a symbiotic relationship.
- symbiosis** A long-term association between organisms of different species; derived from the terms *biosis* (living) and *sym* (with).
- syntrophism** The relationship where the metabolism of one microorganism enables a second microorganism to grow.
- thallus** The structure or body of lichen, large fungus, or algae.
- thrombolites** Microbialites with macroscopically clotted mineral fabrics.
- transcriptomics** The study evaluating the presence of specific mRNA produced by an organism.
- trichome** A linear array of cells that function as a single unit.
- UMB** Ultramicroscopic bacteria; cells of reduced size that are produced as a result of starvation.
- vegetative cells** Actively metabolizing and dividing cells.
- vertical transmission** A process in which endosymbionts are transferred from the mother to the egg or embryo.
- xenobiotic** A chemical produced in the laboratory and not produced by any living system.





---

# MICROBIAL ECOLOGY: BEGINNINGS AND THE ROAD FORWARD

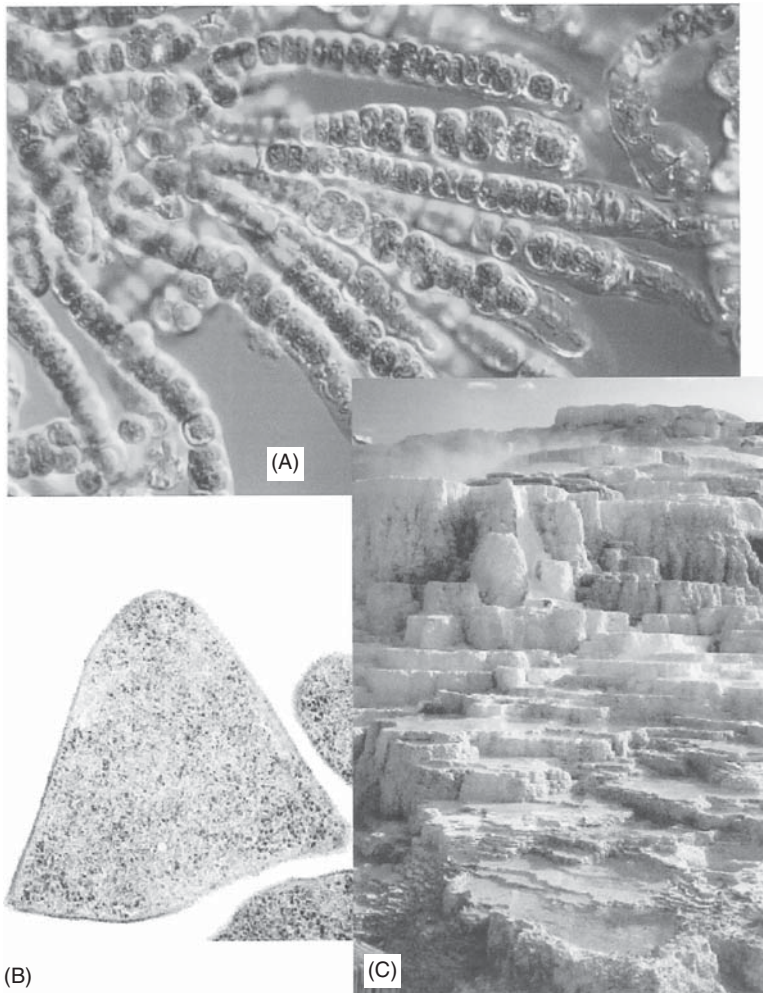
---

## 1.1 CENTRAL THEMES

- Interdisciplinary studies addressing the origin and evolution of life stimulate many ongoing conversations and research activities.
- Prokaryote classification is based on biochemical and physiological activities as well as structures including cell morphology. Classification within Bacteria and Archaea domains is complicated because the definition for a prokaryotic species is currently under review.
- Our knowledge of the microbial diversity of Earth is growing exponentially with the discovery and implementation of molecular phylogeny to study environmental microbiology.
- Configuration of the “tree of life” has changed since the 1990s with the use of molecular and genomic techniques to evaluate microbial relationships.
- Microbial ecology as a discipline will benefit substantially from the development of a theoretical basis that draws on principles identified in general ecology.

## 1.2 INTRODUCTION

The study of microbial ecology encompasses topics ranging from individual cells to complex systems and includes many different microbial types. Not only is there a visual difference in examining pure cultures and unique microbial environments (see Figure 1.1), but also there is a difference in study approach in each of these images. Microbial ecology has benefited from studies by scientists from many different scientific fields addressing environments throughout the globe. At this time there is considerable interest in understanding microbial community structure in the environment. To achieve this understanding, it is necessary to identify microbes present; this can be



**Figure 1.1.** Understanding our environment through the study of cells and systems: (A) *Fischerella* sp; (B) electron micrographs of the triangular archaea, *Haloarcula japonica* TR-1 (provided by Yayoi Nishiyama); (C) Mammoth Hot Springs in Yellowstone National Park. (Photos A and B courtesy of Sue Barns). See insert for color representation.

accomplished by using molecular methods even though the microbes have not been cultivated in the laboratory. Enzymatic activities of microorganisms and microbial adaptations to the environment are contributing to our knowledge of the physiological ecology of microorganisms.

Persistent questions about microorganisms in the environment include:

- Which microbes are present?
- What is the role of each species?
- What interactions occur in the microbial environment?
- How do microbes change the environment?

While this book provides some answers to these questions, each discovery brings with it more questions. The objective of this book is to emphasize the basics of microbial ecology and to explain how microorganisms interact in and with the environment.

### 1.2.1 Roots of Microbial Ecology

For centuries and long before bacteria were known, people from different regions around the world used selective procedures to influence the production of desired foods. Starter cultures were passed throughout a community to make fermented milk, and common procedures were used for fermentation of fruit juices. Pickling procedures involving normal fermentations were customary for food preservation. In various regions of the world, increased production of rice resulted from specific practices that we now understand select for the growth of nitrogen-fixing cyanobacteria. Some consider that microbiology started with the reports by Anton van Leeuwenhoek (1632–1723) in 1675 with the description of “very little animacules” that have the shape of bacteria, yeast, and protozoa. The environments that van Leeuwenhoek examined included saliva, dental plaque, and contaminated water. Gradually, information on microorganisms appeared as scientists in various countries explored the environment through direct observations or experimentation (Brock 1961; Lechecalier and Solotorovsky 1965). Early discoveries relevant to microbial ecology are listed in Table 1.1 (Schlegel and Köhler 1999). The contributions of scientists to disprove the “doctrine of spontaneous generation” had a great impact on microbiology, and especially important was the presentation by Louis Pasteur (1822–1895) in 1864 at the Sorbonne in Paris. In addition to studying the role of microorganisms in diseases and their impact on our lives, Pasteur emphasized the importance of microorganisms in fermentation. Many consider that the founders of microbial ecology were Sergei Winogradsky (1845–1916) and Martinus Beijerinck (1851–1931), who were the first to demonstrate the role of bacteria in nutrient cycles and to formulate principles of microbial interactions in soil. Beijerinck worked at the Delft Polytechnic School in The Netherlands, where he developed the enrichment culture technique to isolate several bacterial cultures, including those now known as *Azotobacter*, *Rhizobium*, *Desulfovibrio*, and *Lactobacillus*. Also, Beijerinck’s early studies contributed to the demonstration of the tobacco mosaic virus and provided insight into the principles of virology. Winogradsky was a Russian soil microbiologist who developed the concept of chemolithotrophy while working with nitrifying bacteria. In addition to demonstrating that bacteria could grow autotrophically with CO<sub>2</sub> as the carbon source, Winogradsky established the concept of nitrogen fixation resulting from his experimentation with *Clostridium pasteurianum*.

TABLE 1.1. Pioneers in the Field of Microbial Ecology

Year	Individual	Contribution
1683	Antonie van Leeuwenhoek	Published drawings of bacteria showing rods, cocci, and spirals
1786	Otto Friedrich Müller	Reported the characteristics of 379 different species in his publication <i>Animalcules of Infusions, Rivers and the Sea</i>
1823	Bartholomeo Bizio	Described the “blood” drops in “bleeding” bread used in communion rites as attributed to <i>Serratia marcescens</i>
1837	FriedrichTraugott Kützing, Charles Cagniard-Latour, and Theodor Schwann	Independently published papers stating that microorganisms were responsible for ethanol production
1838	Christian Gottfried Ehrenberg	Described <i>Gallionella ferruginea</i> as responsible for ocher
1843	Friedrich Traugott Kützing	Described <i>Leptothrix ochracea</i> , a filamentous iron-oxidizing bacterium
1852	Maximilian Perty	Described several species of <i>Chromatium</i> including <i>C. vinosum</i>
1866	Ernst Haeckel	Proposed the term <i>ecology</i>
1877	Theophile Schoesing and Achille Muntz	Demonstrated that microorganisms were responsible for nitrification ( $\text{NO}_3^- \rightarrow \text{NH}_3$ )
1878	Anton de Berry	Proposed concepts of mutualistic and antagonistic symbiosis
1885	A. B. Frank	Described the fungus–root symbiosis known as <i>mycorrhiza</i>
1886	H. Hellriegel and H.Wilfarth	Demonstrated that root nodules on legumes supplied nitrogen to plants
1889	Matrinus W. Beijerinck	Developed enrichment technique that produced pure cultures of many bacteria in nitrogen–sulfur cycle
1889	Sergus N. Winogradsky	Established concept of chemolithotrophy and autotrophic growth of bacteria
1904	L. Hiltner	Studied the biology of the root zone and proposed the term <i>rhizosphere</i>
1909	Sigurd Orla-Jensen	Presented a natural system for arrangement of bacteria with lithoautotrophs as the most primitive bacteria

With an increased interest in microbiology, it became apparent that there was a highly dynamic interaction among microorganisms and also between microorganisms with their environment. Today the study of microbial ecology includes many different fields, and these are addressed in subsequent chapters of this book.

### 1.2.2 Current Perspectives

The study of microbial ecology includes the influence of environment on microbial growth and development. Not only do physical and chemical changes in the environment select for microorganisms, but biological adaptation enables bacteria and archaea to optimize

the use of nutrients available to support growth. The prokaryotic cell was the perfect system for early life forms because it had the facility for rapid genetic evolution. As we now understand, horizontal gene transfer (Section 4.7.2) between prokaryotes serves as the mechanism for cellular evolution of early life forms to produce progeny with diverse genotypes and phenotypes. While fossils provide evidence of plant and animal evolution, fossils can also provide evidence of early animal forms that have become extinct. It is an irony in biology that the same prokaryotic organisms that evolved to produce eukaryotic organisms also participated in the decomposition of dinosaurs and other prehistoric forms. The prokaryotic form of life not only persists today but thrives and continues to evolve. It has been estimated that there are more living microbial cells in the top one inch of soil than the number of eukaryotic organisms living above ground. William Whitman and colleagues have estimated that there are  $5 \times 10^{30}$  (five million trillion trillion) prokaryotes on Earth, and these cells make up over half of the living protoplasm on Earth (Whitman et al. 1998). The number of bacteria growing in the human body exceeds the number of human cells by a factor of 10 (Curtin 2009). While it is impossible to assess the role of each of these prokaryotic cells, collectively groups of prokaryotic cells can have considerable impact on eukaryotic life. Analysis of the human microbiome reveals that although the microbial flora of the skin is similar, each human has a bacterial biome that is unique for that individual (Curtin 2009). Not only are microorganisms important in cycling of nutrients but they have an important role in community structure and interactions with other life forms. It would be impossible to envision life on Earth without microorganisms. Before addressing important divisions in microbial ecology, it is useful to reflect on the development of microbes on Earth.

### 1.3 TIMELINE

Formation of Earth occurred about 4.5 billion years ago, and this was followed by development of Earth's crust and oceans. Volcanic and hydrothermal activities of Earth released various gases into the atmosphere. In addition to water vapor, dinitrogen ( $N_2$ ), carbon dioxide ( $CO_2$ ), methane ( $CH_4$ ), and ammonia ( $NH_3$ ) were the major atmospheric gases, while hydrogen ( $H_2$ ), carbon monoxide ( $CO$ ), and hydrogen cyanide ( $HCN$ ) were present at trace levels. Chemical developments of prebiotic Earth relevant to the evolution of life have been critically reviewed by Williams and Fraústo da Silva (2006). The anaerobic environment on Earth provided the reducing power for the formation of the first organic compounds.

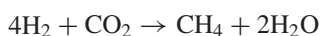
Early life forms were anaerobes that included thermophilic  $H_2$ -utilizing chemolithotrophs, methanogens, and various microbes displaying dissimilatory mineral reduction. Hyperthermophilic prokaryotes are proposed to have been one of the earliest life forms, and Karl Stetter has collected over 1500 strains of these organisms from hot terrestrial and submarine environments (Stetter 2006). There is considerable abundance of these microorganisms in the environment, with  $10^7$  cells of *Thermoproteus* found in a gram of boiling muds near active volcanoes,  $10^8$  cells of *Methanopyrus* found in a gram of hot vent chimney rock, and  $10^7$  cells of *Archaeoglobus* and *Pyrococcus* found per milliliter (mL) of deep subterranean fluids under the North Sea (Stetter 2006). While the hyperthermophiles characteristically grow at 80–113°C with a range of pH 0–9.0, one archaeal species, *Pyrolobus fumarii*, withstands one hour in an autoclave that has a temperature of 121°C. Currently, about 90 species

TABLE 1.2. Examples of Hyperthermophilic Prokaryotes

Genera of Archaea	Genera of Bacteria
<i>Acidianus</i>	
<i>Archaeoglobus</i>	<i>Aquifex</i>
<i>Ferroglobus</i>	<i>Desulfurobacterium</i>
<i>Igniococcus</i>	<i>Thermocrinis</i>
<i>Metallosphaera</i>	<i>Thermotoga</i>
<i>Methanopyrus</i>	<i>Thermovibrio</i>
<i>Methanothermus</i>	
<i>Nanoarchaeum</i>	
<i>Pyrococcus</i>	
<i>Pyrodictium</i>	
<i>Pyrolobus</i>	
<i>Sulfolobus</i>	
<i>Thermococcus</i>	
<i>Thermofilum</i>	
<i>Thermoproteus</i>	

of microorganisms are hyperthermophiles, and some of these species are listed in Table 1.2. Most hyperthermophiles are chemolithotrophic organisms using molecular hydrogen ( $H_2$ ) as the electron source for energy-yielding reactions. While many of the hyperthermophilic archaea use  $S^0$  as the electron acceptor, some hyperthermophiles can couple growth to the use of  $Fe^{3+}$ ,  $SO_4^{2-}$ ,  $NO_3^-$ ,  $CO_2$ , or  $O_2$  as electron acceptors. Molecular oxygen ( $O_2$ ) is a suitable electron acceptor for a few hyperthermophilic archaea, and in these cases only under microaerophilic conditions. Hyperthermophilic bacteria usually require organic material to support their anaerobic or aerobic growth. Many of the anaerobes have active systems using  $H_2$  as the electron donor.

The biological production of methane is considered to be an ancient process and would have been attributed to prokaryotes catalyzing the following reaction:

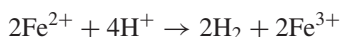


When organic compounds such as acetate accumulated in the environment, methanogens could have produced methane from methanol, formate, or acetate. Only members of the Archaea domain are capable of methane production.

Chemoautotrophic microbes could have evolved to grow on the energy from oxidation of molecular hydrogen and reduction of carbon dioxide according to the following reaction:



In addition to the production of  $H_2$  from geologic formations, ultraviolet radiation could have released  $H_2$  according to the following reaction:



Another source of  $H_2$  would be the radiolysis of water attributed to alpha radiation (Landström et al. 1983). With the accumulation of diverse organic compounds in the

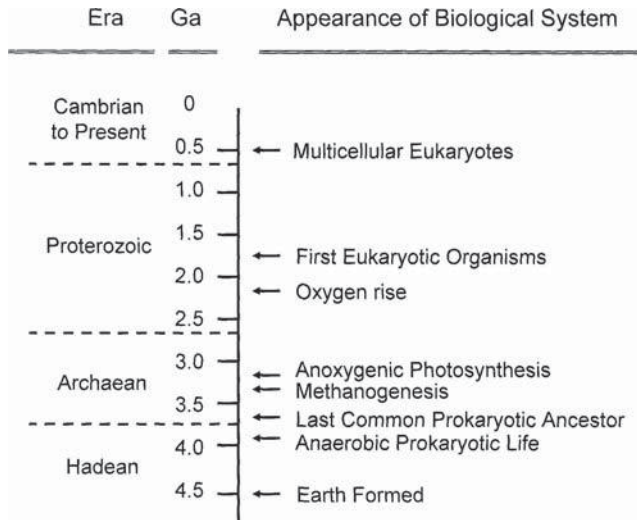


Figure 1.2. Early development of life.

environment, heterotrophic prokaryotes metabolizing organic carbon materials would have appeared sometime after the chemoautotrophs were established.

As presented in Figure 1.2, anaerobic photodriven energy activities may have been present ~3 billion years ago, using light to activate bacteriorhodopsin-like proteins to pump ions across cell membranes. The bacteriorhodopsin type of photodriven energetics would have been followed by chlorophyll-containing anoxygenic bacterial photosynthesis involving purple and green photosynthetic bacteria where  $H_2S$  was the electron source. While microbial evolution was initially in the marine environment, microorganisms may have migrated to dry land about 2.75 billion years ago (Rasmussen et al. 2009). Cyanobacteria with oxygenic photosynthesis produced the aerobic atmosphere, and this has been called the “great oxidation event.” Since  $O_2$  was produced from water by the photocatalytic process, the rate of  $O_2$  released was not limited by availability of water.

Once molecular oxygen was released into the atmosphere, it reacted with reduced iron and sulfur compounds (i.e.,  $FeS$  and  $FeS_2$ ) to produce oxidized inorganic compounds by both microbial and abiotic processes. Gradually the  $O_2$  level in Earth’s atmosphere increased and by ~1.78–1.68 billion years ago oxygen respiration could have been used to support the growth of the first single-cell eukaryotes (Rasmussen et al. 2008). Another important development of an aerobic atmosphere was the generation of ozone ( $O_3$ ) from  $O_2$  due to a reaction with ultraviolet light. Ozone absorbs ultraviolet light and forms a protective layer in the atmosphere to shield Earth from destructive activity of ultraviolet radiation (Madigan et al. 2009). Prior to the development of an ozone layer, microorganisms would have been growing only in subsurface areas or in environments shielded by rocks.

## 1.4 MICROFOSSILS

Fossils are important for understanding the evolution of plants and animals; however, there are few fossils available for microorganisms. Dating of dinosaur presence can



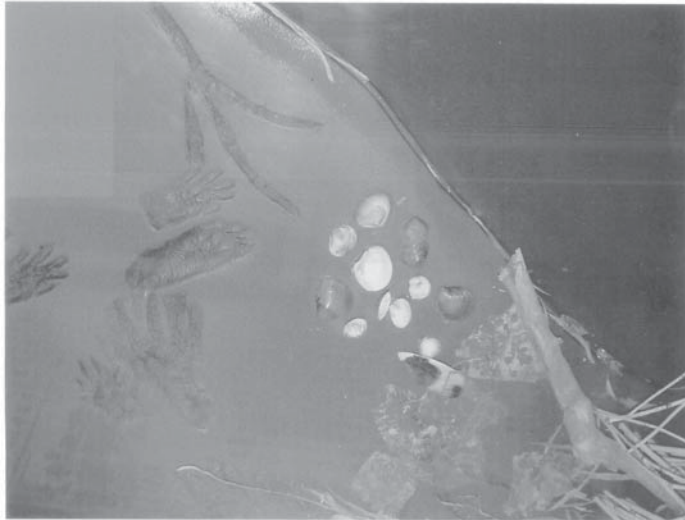


**Figure 1.3.** Dinosaur footprints present on surface stone in Texas (A) and Arizona (B). [Photograph (A) by Diana Northup, (B) by Larry Barton]. See insert for color representation.

be derived from bone fragments or footprints left in mud (Figure 1.3). As depicted in Figure 1.4, footprints can provide considerable information about the presence of life; however, the early history of microorganisms is relatively sparse. Electron microscopy of aggregates found in the Archean Apex chert of Western Australia revealed cell-like structures characteristic of cyanobacterial trichomes, and these were reported to be 3.5 billion years old (Schopf 1993). However, the inability to demonstrate appropriate biomarkers in the microfossils has generated concern about the dating of these images (Rasmussen et al. 2008). Fossilized stromatolites (see Section 11.10 for additional information) consisting of mats of cyanobacteria and other microorganisms were reported to be present in rocks from the Warrawoona Group in Western Australia. Images of bacteria are suggested in scanning electron micrographs of rocks that are 3.4 billion years old from the Barberton Greenstone Belt, South Africa. From carbonaceous chert in the Ural Mountains there are structures resembling the bacterium *Gleodiniopsis*, and this has been dated to be 1.5 billion years old. Microfossils of the cyanobacterium *Palaeolyngbya* are 950 million years old and were found in the Khabarousk region in Siberia.

Konhauser (2007) has critiqued the use of Archean microfossils in dating primitive aerobic phototrophs. Some scientists maintain that the mere presence of kerogen in microfossils is not sufficient to indicate biogenic origin. Biomarkers useful in suggesting the presence of prokaryotes would be the lipid soluble hopanes and steranes that would be derivatives of hopanoids and sterols, respectively. Degradation products of these compounds are useful in assessing the biogenic character of microfossils because hopanoids are lipids characteristically found in the plasma membrane of prokaryotes and sterols are typically found in the membranes of eukaryotic cells. An additional significance in finding derivatives of sterols in microfossils is that molecular  $O_2$  is required for one of the final enzyme steps in the biosynthesis of sterols. Of course, definitive proof of life in the microfossils would be the detection of DNA or decomposition products of DNA.





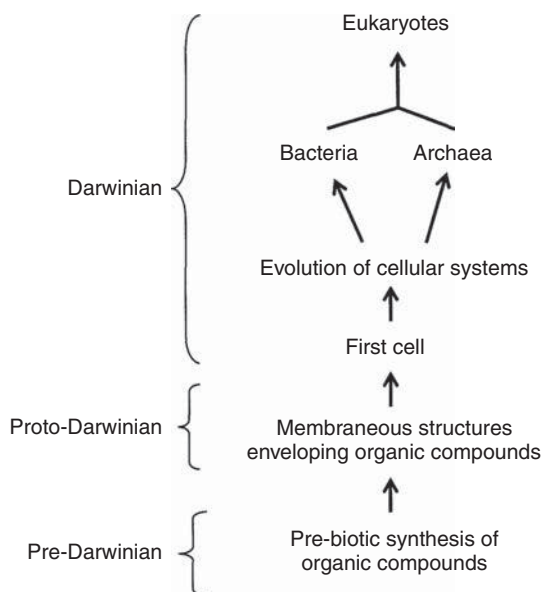
**Figure 1.4.** Examples of organisms present in a specific environment: footprints of several animals and shell records; exhibit at the educational center in Albuquerque museum (photograph by Larry Barton). See insert for color representation.

## 1.5 EARLY LIFE

The origin of life on Earth is a topic that has attracted the attention of many scientists and has resulted in publication of numerous fascinating opinions. In a more recent review, Koch and Silver (2005) discuss the stages required in development of chemical processes into a biological unit. The transition from an abiotic environment to a world with microorganisms is summarized in Figure 1.5. Using cellular evolution as a perspective, early development of the evolutionary tree of life could be divided into various phases (Koch and Silver 2005): (1) the *pre-Darwinian phase*, which represents Earth's environment prior to the formation of a cell; (2) the *proto-Darwinian phase*, during which the first cell was formed; and (3) the *Darwinian phase*, which involved selective pressures on cell development that favored diverse forms of prokaryotes and eukaryotes.

### 1.5.1 The Precellular World

The *precellular phase* would involve astrophysical and geochemical activities at a time before the presence of biological cells. The activities involved in formation of small organic molecules (e.g., sugars, amino acids, lipids, porphyrins, nucleotides, heterocyclic bases) may have been unrelated. There are several different opinions concerning the energy sources and sites or regions where synthesis of organic molecules may have occurred. Wächtershäuser (1990) proposed that the organic macromolecules were produced on clay-like surfaces, while Koch (1985) and Deamer (1997) supported the idea that vesicles enclosed with membrane-like structures were involved in the formation of organic molecules. Some have supported the idea that life arose from a "primordial soup" in a lake on the surface of Earth, while others consider that life arose from a subsurface



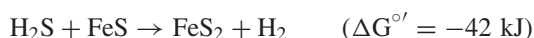
**Figure 1.5.** Evolutionary development of early life [modified from Koch and Silver (2005)].

spring. All of these theories provide for an interesting interplay of geochemical processes that may have culminated in biological activity.

### 1.5.2 The First Cell

Prior to the first living cell, various organic compounds presumably accumulated in the environment. Koch and Silver (2005) propose that prebiotic compounds could have included nucleic acid inside a vesicle and that the vesicle had a mechanism for generating an ionic charge across the membrane barrier. It was not necessary for this first cell-like unit to have enzymes for metabolism, nor was there a requirement for ATP, ribosomes, proteins, or DNA. The presence of a self-replicating single-stranded RNA with autocatalytic activity, also known as *ribozyme*, could provide a basis for development of molecular biology in this evolutionary process. The membrane provided a lipid closure for the vesicle, and in terms of structure and composition the early membrane may have been different from current unit membranes.

Energy is paramount for development of life and could have resulted from the following reaction:



The oxidation of inorganic compounds (see Section 11.4 for additional information), such as given in the reaction above, could have provided the potential for various reactions, including the generation of an ionic gradient across the membrane. This vesicular structure would not yet be a cell but could evolve into a cell after acquiring DNA, proteins for metabolism, ribosomes, ATP, and related components. The presence of RNA in the first membrane vesicle would have been useful because even a small RNA molecule is highly charged and could nonspecifically bind protein and small organic molecules found

in the environment. DNA replaced RNA as the molecule carrying genetic information and was more stable than RNA. Undoubtedly, the time required for development of the first self-replicating unit (cell) was considerable, but once this process was achieved, cellular evolution proceeded at an accelerated rate. The extent of evolution by eukaryotes is apparent when reviewing the diversity of eukaryotic life forms, but it should be recalled that eukaryotes have been on Earth for only one-third as long as prokaryotes.

### 1.5.3 Development of Cellular Biology

With the presence of DNA and other protein-synthesizing materials inside the membrane vesicle, the cell had the capability for heredity with new phenotypes expressed. Evolution leading to different lifestyles and life forms could follow selection based on the hypothesis of Alfred Wallace and Charles Darwin. The bacterial and archaeal species surviving and reproducing in an environment were the ones capable of dealing with that environment. The evolutionary process was not continuous, but changes in genetic information would have been displayed by periodic environmental changes providing the selective pressure that led to new cell types. Genetic variation in these asexual microorganisms would be attributed to mutations and horizontal (lateral) gene transfer (Section 4.7.2). There is no record suggesting the events responsible for the universal ancestor to produce two lineages of prokaryotes (i.e., Bacteria and Archaea). Many of the biomolecules and biochemical processes found in Bacteria and Archaea are similar, but numerous details in accomplishing certain activities distinguish organisms of these two domains. Since prokaryotes were the only living organisms on Earth for over 2 billion years, it is rather remarkable that only two prokaryotic cell types were produced.

One theory for the formation of a eukaryotic cell is the establishment of a nucleus prior to the development of mitochondria and chloroplasts by endosymbiosis (see Section 8.2 for additional information). The *genome fusion hypothesis* has been developed to explain the formation of the eukaryotic nucleus where the eukaryotic genome arose from a combination of archaeal and bacterial genes. An examination of energy production and chemistry of lipids in the cell membrane reveals that eukaryotic cells are more similar to Bacteria than to Archaea. However, when examining transcription and translation processes, eukaryotes have characteristics of the Archaea. As the genome of the ancestral eukaryote increased in size, chromosomes were developed to enhance organization of DNA, and it has been proposed that the nuclear membrane arose spontaneously to segregate DNA from the cytoplasm. More recently it has been discovered that one bacterial species has a “primitive” nuclear membrane (see Section 3.8.3), and the function of this internal membrane is unresolved.

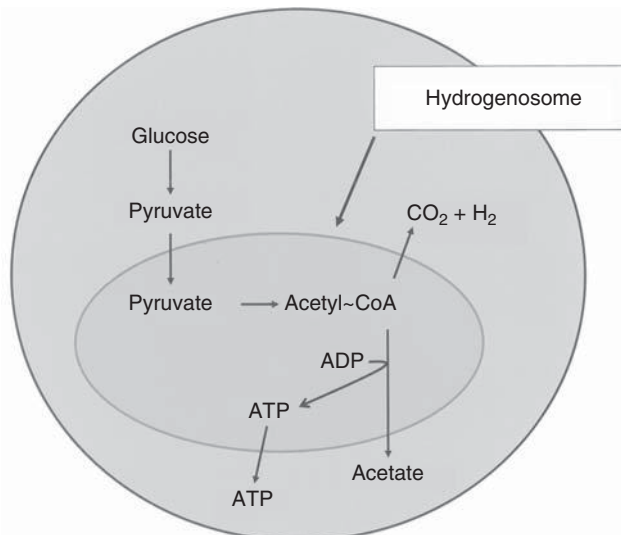
The *endosymbiotic hypothesis* (see Section 8.2) addresses the origin of chloroplasts and mitochondria where both of these organelles developed from bacteria. Lynn Margulis (see “Microbial spotlight” in Chapter 8) suggests that the formation of the eukaryotic cell is a product of several sequential endosymbiotic steps. Spirochete bacteria were an early surface symbiont with an anaerobic organism resulting in motility of the eukaryotic cell. Endosymbiotic activity contributed to the development of mitochondria and chloroplasts. The endosymbiont provided the host with a capability useful to the host cell, while the endosymbiont benefited from nutrients and a safe environment provided by the host. Some have proposed that the primitive eukaryotic cell receiving the endosymbiont was derived from the archaeal cell line. Genes for the synthesis of bacterial-like membranes may have been transferred to the host archaeal cell and may have promoted the early

development of cytoplasmic membranes. The genome of *Rickettsia prowazekii*, a member of the Alphaproteobacteria, is remarkably similar to the mitochondrial genome, and additional inspection is required to determine whether it was the source of the mitochondria or if both the mitochondria and rickettsia evolved from a common ancestor. Most likely chloroplasts developed in the cell line producing higher plants. Chloroplasts in green algae and higher plants could have evolved from *Prochloron*, a cyanobacterium, because it is the only aerobic photosynthetic cell that has both chlorophyll *a* and *b*.

An alternate idea pertaining to development of organelles in eukaryotes is the *hydrogen hypothesis*. The endosymbiont in this situation is proposed to be an anaerobic member of the Alphaproteobacteria that releases  $\text{CO}_2$  and  $\text{H}_2$  as end products. This endosymbiont is proposed to evolve along two distinct lines to produce a hydrogenosome for anaerobic metabolism and a mitochondrion for aerobic respiration. The hydrogenosome (Figure 1.6) would obtain ATP from pyruvate metabolism with the release of  $\text{CO}_2$  and  $\text{H}_2$ . From genome analysis, it appears that there is considerable similarity between the genomes of hydrogenosomes and mitochondria.

#### 1.5.4 Evolution of Metabolic Pathways

The origin and evolution of metabolic pathways were important for molecular evolution and are attracting considerable attention (Canfield et al. 2006; Falkowski et al. 2008; Fani and Fondi 2009; Fondi et al. 2009). Many consider that ancestral cells, in comparison to current prokaryotic cells, had relatively few genes, no gene regulation, and no mobile genetic elements. While early cells may have had only a few hundred genes, the expansion of the genome to several thousand genes per cell could be explained by the “patchwork” hypothesis (Jensen 1976; Ycas 1974), in which genes encoding for enzymes of low specificity were duplicated, and through selective pressures evolved into genes encoding for enzymes of considerable specificity. In terms of gene duplication there could be duplication of the entire gene, a part of a gene, or several genes from the same or different



**Figure 1.6.** Hydrogenosome in the eukaryotic cell.

metabolic pathway. Gradually the primordial cells expanded their metabolic capabilities and established regulatory mechanisms. Cells with efficient metabolic pathways were selected through pressures of population growth. Genetic exchange between cells involving horizontal gene transfer and fusion of protoplasmic prokaryotic cells would have been important in early evolutionary processes. Initially it may have been more important for transfer of operational genes than for transfer of genes involved in information processing (transcription, translation, etc.). Abiotic geochemical cycles were replaced (or supplemented) by biotic processes, resulting in interconnection of biogeochemical cycles.

## 1.6 CHARACTERISTICS OF MICROBIAL LIFE

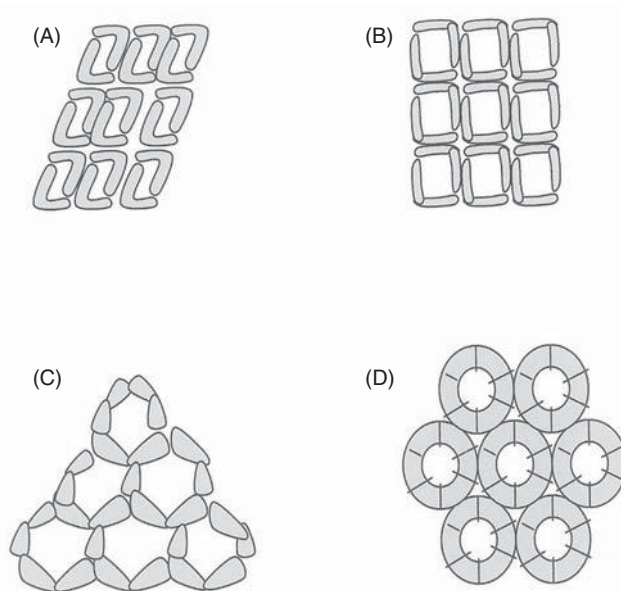
The characteristics of life that have become associated with microorganisms are similar to those of higher plants and animals. A distinguishing feature is that for microorganisms a cell constitutes the individual while with higher forms of life the individual is multicellular and even contains numerous tissues. The biochemical and physiological processes seen in microorganisms are compared in Table 1.3. Introductory courses in biology include a listing of the characteristics defining life, and it is important to reflect on these characteristics of life since they also pertain to prokaryotes. The following discussion addresses how bacteria and archaea conform to the requirements of a defined structure, metabolism, growth, reproduction, and response to stimulus.

### 1.6.1 Structure and Evolution of Cell Shape

Cells of microorganisms have a precise organization and their structure is continuous with their progeny. While crystals of minerals show organization due to alignment of inorganic atoms, differences in crystal organization occur as seen in the differences in the structure of snowflakes. Structural organization in microbial cells reflects the molecular alignment in membranes, ribosomes, protein cell walls, DNA, and other macromolecules. The molecular architecture in the cell walls of microorganisms is reproduced in the progeny of each species. An example of this structural organization is seen in the mosaic arrangement seen on the surface of bacteria and archaea that have been designated as the S layer. Glycoproteins form a lattice with the precision of crystalline minerals, and models of the lattice are shown in Figure 1.7.

TABLE 1.3. Selected Phenotypic Characteristics of Bacteria, Archaea, and Eukarya

Characteristic	Bacteria	Archaea	Eukarya
Dissimilatory reduction of $\text{SO}_4^{2-}$ or $\text{Fe}^{3+}$	Yes	Yes	No
Nitrification	Yes	Yes	No
Denitrification	Yes	Yes	No
Nitrogen fixation	Yes	Yes	No
Chemolithotrophy	Yes	Yes	No
Methanogenesis	No	Yes	No
Oxygenic photosynthesis (chlorophyll-based)	Yes	No	Yes
Anaerobic photosynthesis (chlorophyll-based)	Yes	No	No
Rhodopsin-based energy metabolism	Yes	Yes	No

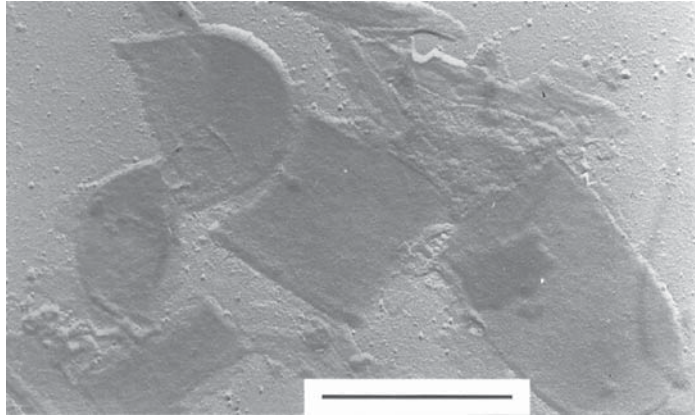


**Figure 1.7.** S layer of microorganisms as examined with freeze-etched preparations or atomic force microscopy displays a surface composed of proteins in four different lattice formations: (A) oblique lattice; (B) square lattice; (C) hexagonal–triangular lattice; (D) hexagonal rosette lattice [modified from Sleytr et al. (1996)].

Another example of an important structure in prokaryotes is the plasma membrane or cell membrane, which functions as a barrier to segregate molecules essential for cellular growth from the extracellular environment. The chemical structure of the plasma membrane includes lipids that form a hydrophobic barrier and proteins that contribute to solute transport, metabolic processes, and communication between the cytoplasm and the environment. Lipids found in prokaryotes consist of phospholipids and fatty acids or fatty acyl groups attached to the glycerol backbone. Although there is a molecular distinction in the lipids found in archaeal and bacterial cells, lipophilic affinity of these molecules functions to stabilize the plasma membrane (Madigan et al. 2009). Phosphate moieties and other charged groups on the surface of the membranes are important for carrying the charge on the membrane. Integrity of the membrane structure is required for cell viability, and disruption of this organization results in cell death.

The cell wall is an important structure for bacterial and archaeal cells in that it prevents osmotic disruption of the cell and contributes to cell shape. For bacteria, rigidity of the cell wall is attributed to a macromolecule called *peptidoglycan* that consists of a sugar polymer with a covalent crossbridge to peptides. Even after disruption of the bacterial cell, the structure of the peptidoglycan is evident (see Figure 1.8). *N*-Acetylglucosamine and *N*-acetylmuramic acid make up the dimer that contributes to the linear strength of the peptidoglycan molecule. As discussed in general texts (Madigan et al. 2009), the crossbridge peptide in the peptidoglycan contains alternating D and L forms of amino acids. Considerable similarity of cell wall composition is found in all of the various types of bacteria; the quantity of peptidoglycan surrounding Gram-positive bacteria is greater than that found with Gram-negative cells. While the cell wall in archaea does not

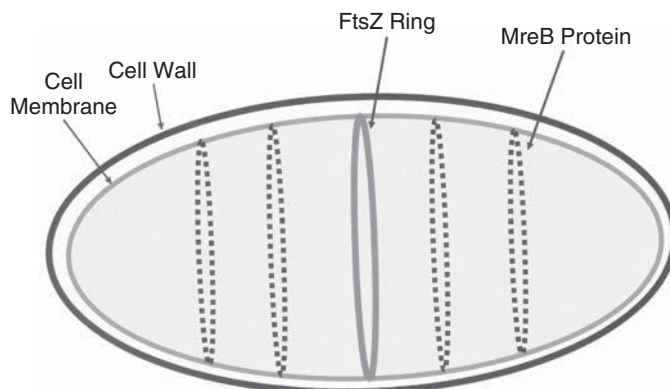




**Figure 1.8.** Remnants of the peptidoglycan structure of *Bacillus stearothermophilus* after destruction of bacterial cell by high-pressure treatment (electron micrograph provided by Sandra Barton).

contain peptidoglycan, the covalent bonds attributed to polymers of L forms of amino acids and sugars provide for structural stability of the archaeal cell.

Specific proteins account for cell division and cellular form for prokaryotic cells. For cell division, there are a series of proteins located on the inner side of the cell membrane, and prior to binary fission many of these proteins polymerize to form the FtsZ ring located at the midpoint of the cell. The FtsZ ring recruits other proteins for the division process and is present in both archaea and bacteria. To underscore the evolutionary relationship between prokaryotes and eukaryotes, FtsZ-like proteins are also found in chloroplasts, mitochondria, and cell division proteins in eukaryotes. Additional proteins on the inner side of the cell membrane in bacteria and archaea are the MreB proteins (Figure 1.9). The MreB proteins influence the localized synthesis of the cell wall and account for the rod-shaped cell form. Bacteria without the genes for the production of MreB proteins are of the coccus form. Scientists speculate that the ancestral cell was spherical and the rod form appeared with the development of the specific gene for MreB synthesis. Some

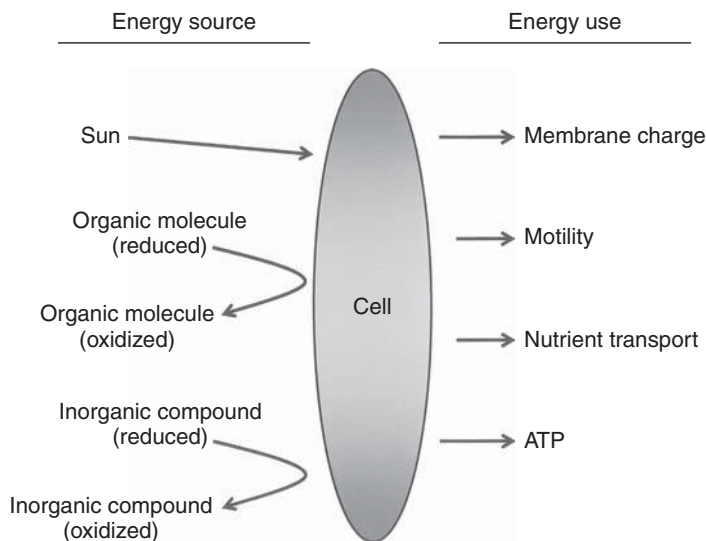


**Figure 1.9.** Localization of FtsZ and MreB proteins in a bacterial cell.

bacteria have a curved rod shape also known as a *vibrio form*. In one vibrio-shaped bacterium, *Caulobacter crescentus* (Section 3.7), the cell shape is attributed to crescentin in addition to MreB. The crescentin proteins accumulate on the concave face of the vibrio cell and contribute to the curvature of the cell. Since proteins similar to crescentin have been found in another vibrio, *Helicobacter*, some have suggested that unique proteins are needed to produce a curved bacterial cell.

### 1.6.2 Metabolism and Use of Energy

Microbial cells use chemical energy from organic compounds, minerals, and light-driven reactions. While solar energy is restricted to microorganisms at Earth's surface, the use of reduced organic compounds or inorganic materials provides energy for metabolic reactions in anaerobic and aerobic environments. A hallmark characteristic of living systems is the flow of electrons from electron donors to electron acceptors, and this characteristic is observed in both aerobic and anaerobic cultures (see discussion on energetics in Chapter 3). The generation of ATP and establishment of a charge on the cell membrane are coupled to this electron flow. As indicated in the model in Figure 1.10, energy from cell metabolism is also used for motility and nutrient transport. As with other life forms, metabolism in microorganisms is the summation of incremental changes. Additionally, there is a similarity in all forms of life in that electron transfer is mediated by cytochromes, quinones, and proteins with iron-sulfur centers; however, considerable variability of these electron carriers distinguishes prokaryotes from mitochondria-containing life forms. In terms of transmembrane movement, nutrient transport is driven by chemiosmotic or ion gradients in all living cells with prokaryotes commonly relying on  $H^+$ - or  $Na^+$ -driven transporters.

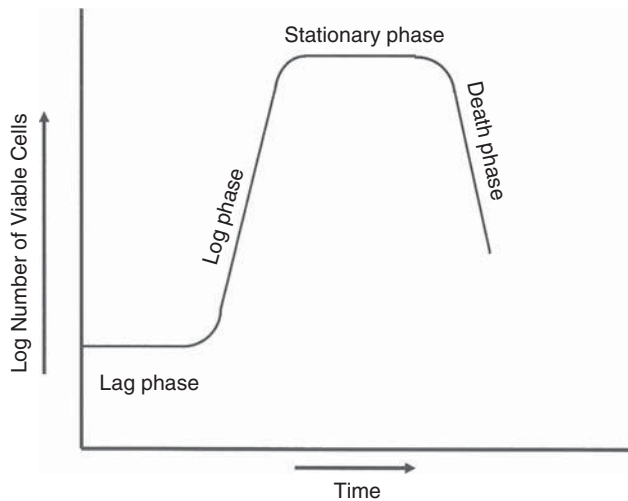


**Figure 1.10.** Energy flow in microorganisms.



### 1.6.3 Growth, Reproduction, and Development

The goal of microbial metabolism is to provide microorganisms with sufficient biosynthetic material in an organized fashion that enables them to reproduce. With bacteria, archaea, and single-cell protists, growth generally implies an increase in the number of individual cells. The idealized growth curve is commonly used to describe bacterial or archaeal growth (Figure 1.11); however, logarithmic growth of these microorganisms is only transiently seen in the environment. As discussed in Box 1.1, logarithmic growth of bacteria or archaea has the potential of quick production of biomass. While there may be bursts of rapid growth by individual species of prokaryotes due to nutrient flux, growth of bacteria or archaea in many stable environments is similar to stationary-phase growth. Although reproduction in bacteria and archaea is asexual, the acquisition of new heredity information from horizontal gene transfer (Section 4.7.2) provides for mixing of the gene pool. The production of spores by bacteria is an asexual process of cell differentiation, with one cell producing one spore. Bacterial spores are produced to enable a species to



**Figure 1.11.** Idealized growth curve for bacteria indicating that the rate of rapidly dividing cells is a logarithmic function.

#### Box 1.1 The Power of Log Growth

Bacteria and archaea grow by binary fission where one cell divides to give two cells, these two cells divide to give four, the four cells divide to give eight, and so the progression of log growth proceeds. If a bacterial species grows with cell division occurring every 60 min, at the end of 96 h there would be  $10^{29}$  cells. If the weight of one cell equals  $2.5 \times 10^{-13}$  g, then at the end of 96 h the mass of bacteria would be  $2.5 \times 10^{13}$  kg. Fast-growing bacteria like *Escherichia coli* divide every 20 min, and at the end of 48 h, *E. coli* would produce a mass of about  $2.2 \times 10^{24}$  kg. It is inappropriate to consider that bacteria in the environment display log growth for any extended time because the mass of Earth is  $5.97 \times 10^{24}$  kg and bacteria could quickly exceed this value.

persist through periods that are detrimental to cells and are not a form of reproduction as is the case of asexual spore formation in fungi. A few bacteria and archaea display cellular differentiation or development, and some bacteria display a simple lifecycle.

#### 1.6.4 Adaptations and Response to Stimuli

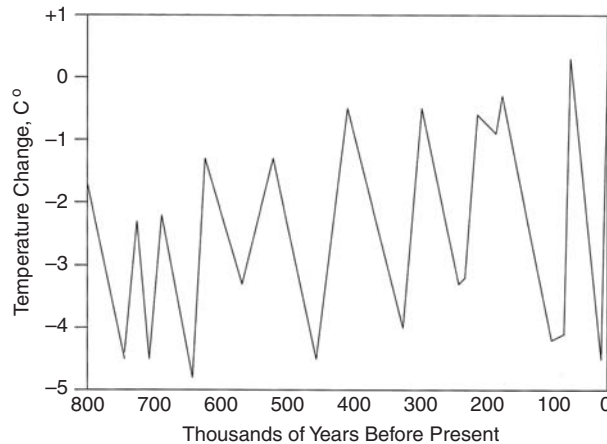
It is desirable for microorganisms to respond to environmental changes so that growth and physiological processes can be maintained at near-optimal conditions. When physical or chemical changes are extreme, selection favors the cell line that has a genetic content that enables cells to grow at low pH, high temperature, high salt content, or other permanent environmental changes. These adaptations can become fixed in a population, resulting in new species with special traits. However, many environmental changes are transient where the duration of the new stimulus is not long but may be relatively frequent. Bacteria and archaea display stress response to many different transient stimuli, including temperature, toxic metals, desiccation, oxygen content, and many other environmental situations. In many instances the response to stimuli may be to promote bacterial movement toward a useful nutrient or desirable environment. Chemotactic movement may be attributed to flagellar or gliding activity and is regulated by a complex sensory process. Bacteria have the capability of transferring a physical or chemical signal across the cell membrane to elicit an appropriate response.

Additionally, numerous metabolic changes occur in microorganisms as they respond to changes in the chemical environment. Induction or repression of gene expression occurs in bacteria in a few minutes, and this enables cells to synthesize only those enzymes needed for catabolism or biosynthesis. Furthermore, microbial cells can modulate gene expression instantaneously as chemical changes occur in the environment. This highly regulated production of enzymes ensures that energy is conserved through the synthesis of only those enzymes that are needed for that environment. This physiological and metabolic adaptability by bacteria enables them to persist in the environment and to successfully compete with eukaryotic life forms.

Bacteria and archaea have made considerable adjustments as Earth's environment has changed over the years. Major changes in Earth's temperature occurred, and microbial life forms responded appropriately. Both microorganisms and hosts were required to adapt for the continuation of parasitic or mutualistic interactions. Ocean temperature has been calculated using oxygen isotope ratio in fossil plankton found in marine sediments and is illustrated in Figure 1.12. Over the past 800,000 years there have been cycles of temperature change with fluctuations of  $\pm 4^{\circ}\text{C}$ ; however, these changes were extremely slow. We are on a global warming cycle and this will have an effect on microbial activities and especially on microbe-host interactions.

### 1.7 CLASSIFICATION AND TAXONOMY: THE SPECIES CONCEPT

The classical definition of a species, as applied to the animal world in particular, includes shared morphological traits and the ability of a group of individuals to interbreed and produce fertile offspring through sexual reproduction. Because reproduction in bacteria, archaea, and some other microorganisms is primarily asexual, this definition immediately runs into trouble with prokaryotic organisms, which exchange DNA through conjugation, transduction, and transformation. To solve this problem, microbiologists used phenotypic



**Figure 1.12.** Marine temperature from measurement of oxygen isotope ratios in fossil plankton [based on data from Imbrie et al. (1984)].

characteristics, metabolism in particular, to discern closely related species. However, the growing realization that we have not figured out how to grow many species in the environment, as revealed by 16S rDNA studies of diversity, has eroded confidence in relying on this method. Microbiologists then proposed the use of a  $\geq 70\%$  level of whole genome DNA-DNA reassociation and similar G-C ratios (the percentage of guanine and cytosine in a genome) to define a species (Staley et al. 2007); however, individuals of a species so defined may share only 80–90% of genes. Some authors use the phylogenetic species concept that specifies that sequence identity of the 16S rRNA gene must be 97% or greater (Madigan et al. 2009) or even 99% sequence identity (Cohan and Perry 2007). The latter is not a good marker for resolving closely related species, however. New ways of approaching the definition of a bacterial/archaeal species are being developed that incorporate an ecological and evolutionary perspective and put the species concept for microorganisms on a more theoretical basis (Cohan and Perry 2007).

Within a bacterial species, there exists what are now termed *ecotypes* that have adapted to their environment in different ways, such as using different carbon sources or mineral nutrients, or using different levels of light energy. Additionally, some species can have strains that are pathogenic, while others within the same species are not pathogenic. Because of the importance of such distinctions, medical microbiologists have separated some of these organisms into distinctly named species, such as *Bacillus anthracis* (pathogenic) and *Bacillus cereus*, while other named species, such as *Escherichia coli*, provide an umbrella for both pathogenic and nonpathogenic strains. Some researchers advocate moving to ecotype-based systematics, in which ecologically distinct species are named and existing species that harbor ecologically distinct strains are given trinomials that include an ecovar epithet to distinguish the different ecotypes contained within a species (Cohan and Perry 2007).

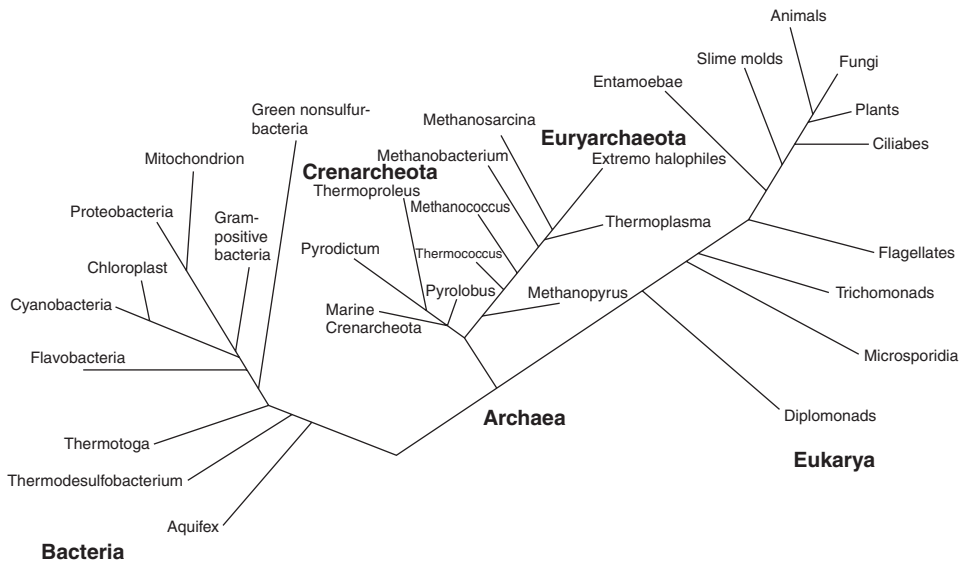
## 1.8 THE THREE DOMAINS: TREE OF LIFE

At one time it was taught that there were five kingdoms of life: Animalia, Plantae, Fungi, Monera, and Protista (Margulis and Schwartz 1998). In the 1970s, this view of

life was challenged by Woese and Fox (1977), who proposed a new division of life, the Archaea (Sections 2.5 and 2.6), as one of the three major lines of descent. This was followed in 1990 by the theory of Woese et al. (1990), that all of life could be classified into three domains: *Bacteria*, which they called *Eubacteria*, *Archaea*, which they called *Archaeobacteria*, and *Eukarya*, which they called *Eucarya*. The methods employed by Carl Woese and Norman Pace [the sequencing of the small subunit (SSU) of the ribosome] touched off studies that revealed that eukaryotes are not the most diverse organisms on Earth, but are far surpassed by the diversity present in the bacteria and archaea (Pace 1997). In proposing this new scheme for the tree of life, Woese et al. noted the following in 1990:

Our present view of the basic organization of life is still largely steeped in the ancient notion that all living things are either plant or animal in nature. Unfortunately, this comfortable traditional dichotomy does not represent the true state of affairs.

The genes that encode the 16S and 18S SSU of the ribosome have been used by many studies of a wide range of environments over recent decades. The universal nature of ribosomal DNA, its highly conserved regions, and the relative ease of sequencing made this an ideal candidate for exploring the natural world. Researchers have found a wealth of microbial sequences that represented new groups of microorganisms, never before cultivated. The diversity revealed in these studies is truly stunning and intriguing. As our knowledge of this diversity grew, we have constructed a “tree of life” that encompasses these three domains of life (Figure 1.13).



**Figure 1.13.** Three domains of life—Bacteria, Archaea, and Eukarya—are depicted in a phylogenetic tree [modified from Madigan et al. (2009)].

## Microbial Spotlight

### NORMAN R. PACE



Norm Pace has long been the proponent and architect of the SEARCH for microbial diversity in the natural world. His route to this passion is a fascinating one that shows the power of early experiences:

I first became aware of microorganisms when I was young, about the age of 12 and my parents bought me a pretty cheap microscope; the microscope didn't work very well, but I could look through the microscope at hay infusions and stuff like that. The thing that I found most remarkable about it was that I could look through the microscope and see all these things in there, but I couldn't find any information about what the hell they were. I tucked away that note that the microbial world was a pretty interesting place, but there didn't seem to be a way to get a handle on it.

I ended up being an RNA jock at the U of I [University of Illinois—UC] . . . and became friends with Carl Woese. [My former wife, Bernadette Pace, did the] first [DNA] hybridization experiments for taxonomy. [From these experiments] Carl got really interested in the residual homology. He argued that that highly conserved regions were "the essence of the RNA molecule." One of my first postdocs, Mitch Sogin, did a 5S catalog from *B[acillus] subtilis*—took 2 years for 120 nucleotides. [Then] the game became how to understand how the 5S rRNA processing enzyme, ribonuclease M5, how it recognized the 5S precursor. We needed the atomic structure, which meant crystallography. [This required a thermophilic molecule that would crystallize well, but it was hard to get the high-temperature RNAs in the quantity needed for crystallography.] I was sitting in my office reading Tom Brock's book *Thermophilic Microorganisms and Life at High Temperatures* and read about Octopus Springs with literally kilogram quantities of pink filaments. "Wow, kilogram quantities, near boiling! 93°C! So I went running out into the lab, and said, guys, look at this! High

temperature microbiology in kilogram quantities. Let's take a bucket of phenol up to Yellowstone and get all the 5S we need . . . and somebody, I forget who, said, "But you don't even know what the organism is. I said, that's okay, we can sequence for it." Intake of breath, "My God!" That was it—I knew immediately what we had. The others knew what we had, they just didn't know what we didn't have, namely a whole understanding of the natural world. So, Octopus Springs became [one of] the first targets of the SEARCH.

To add robustness to the tree of life described by these 16S and 18S rDNA studies, researchers are now mining whole genomes to identify universal protein gene sequences, which have been concatenated to construct phylogenetic trees. Ciccarelli et al. (2006) have used such data to refine the relationships among and within the three domains. In addition to the microbial diversity seen in phylogenetic trees, microorganisms exhibit much greater metabolic diversity than do nonmicrobial eukaryotes and have evolved complex interactions with other microorganisms, plants, and animals.

## 1.9 RELATIONSHIP OF MICROBIAL ECOLOGY TO GENERAL ECOLOGY

The wealth of microbial diversity and the vigorous debate about what constitutes a microbial species highlight one of the major challenges of the evolving field of microbial ecology: the need to provide a theoretical foundation for the organization of the large amounts of new data on microbial diversity. Theories provide explanations of phenomena that have been tested and substantiated and allow us to predict future occurrences. The application of theory into the foundation of microbial ecology allows us to incorporate our predominately quantitative data into an overall framework that provides understanding of the microbial world. An excellent example of the advantages this provides is seen in the application of ecological and epidemiological theory to the study of emerging diseases (Smith et al. 2005). As different scientific disciplines examine the emerging pathogens, they come from different frameworks. The work of early microbiologists and medical scholars (Koch, Pasteur, and Ehrlich) has led to a focus on the individual patient and their interaction with a given pathogen, while epidemiologists focus on populations of pathogens and their interactions with hosts. A third approach involves modeling of host–pathogen interactions using the ecological and evolutionary perspective. The application of ecological theories to this problem have been especially successful in predicting the spread of such diseases as the Ebola virus and rabies, which then allows the application of control measures in the most useful locations. The melding of these three approaches, and the theories underlying them, can provide the best means of controlling emerging diseases (Smith et al. 2005). This is just one example of the many compelling reasons to develop a theoretical basis for microbial ecology.

Prosser et al. (2007) suggest that two factors limit the theory development in microbial ecology:

1. The lack of distinguishing microbial morphological characteristics and our inability to culture many organisms, which have led to a scarcity of data and insights
2. The slow progress in incorporating general ecological theory and quantitative reasoning into microbial ecology education and research

Some scientists also protest that microorganisms are very different than plants and animals because of their small size, diversity, reproductive methods and rates, dispersal means, and metabolic diversity. Does this preclude our application of existing ecological theory to microbial ecology? In actuality, some ecological theory is derived from microbial model systems, which provide a simplified version of interactions that occur in nature (Jessup et al. 2004). The study of such model systems allows us to better understand natural systems and to predict future interactions in nature by testing hypotheses about how ecological processes work. Model microbial systems can allow us to explore several key questions in ecology, such as:

- How do local interactions influence the patterns of diversity seen at larger scales (e.g., landscape)?
- How does the energy available or the productivity of an ecosystem affect the temporal and spatial distribution of organisms?
- What is the relationship between community diversity/complexity and stability?
- Does productivity determine food chain length?

Microorganisms can be quite useful in testing these and other fundamental ecological concepts.

Significant changes lie ahead in bringing a stronger theoretical basis to microbial ecology (Prosser et al. 2007). As discussed in Section 1.7, the development of the ecological species concept versus the traditional biological species concept is a key need in microbial ecology. Because of the stunning amount of microbial diversity in many environments, we currently lack the ability to accurately measure diversity, except in less complex ecosystems. Species abundance curves allow us to theoretically estimate diversity, but accurately measuring diversity remains a challenge. Limited work has been done on microbial species–area relationships, in which microbial diversity is correlated with spatial scales. This is the fertile ground for the development of a theoretical basis for microbial ecology, in which macroecology theory can be linked to a molecular characterization of microbial communities. Along similar lines, much remains to be discovered about the theoretical basis of the relationship between energy available in the ecosystem and microbial diversity (richness and abundance).

## **1.10 CHANGING FACE OF MICROBIAL ECOLOGY**

### **1.10.1 Change in Focus**

The first reports describing the presence of bacteria were important in terms of natural history of the microorganisms, and some of the current interest includes the impact of microorganisms on global activities. When Anton van Leeuwenhoek described the shapes of the bacteria present in scrapings from his teeth and when Martinus Beijerinck reported nitrogen-fixing root nodule bacteria, they contributed to an interest in the types of bacteria in the environment. The isolation of physiologically unique bacteria from every region on Earth provided a wealth of information concerning the ecological role of microorganisms. Over time there has been an expansion of interests to include the contribution of microorganisms to global nutrient cycling, bioremediation, greenhouse gases, and climate change.



More recently, considerable interest has been placed on system-based technologies to evaluate microbial ecology, and these are collectively included as the “omic” technologies. These technologies are heavily dependent on sensitive analytical instrumentation with high flow through capabilities. Several applications to microbial ecology are listed in Table 1.4. and some of these technologies are discussed in Chapter 5. With the availability of DNA and protein sequences, gene content, and sequence structures of many microorganisms, new approaches are being developed to evaluate microbial relationships. One of these studies has raised the possibility that early microbial evolution was influenced by microbes migrating to a terrestrial ecosystem from the marine environment. Battistuzzi and Hedges (2009) have separated bacterial evolution into two major groups: Hydrobacteria and Terrabacteria (see Figure 1.14). Evolution of the Terrabacteria would reflect adaptations to life on land with the development of spore producing *Bacillus*, soil based actinomycetes, and phototrophic cyanobacteria. Another dimension of current research impacting microbial ecology is the more recent report that an engineered genome can be transferred into a bacterial cell (Lartigue et al. 2009). While this will have considerable value for synthetic biotechnology, it may also lead to the *de novo* creation of new bacteria and provide insight into evolution. One could conclude that while analytical techniques will be continued in microbial ecology, systems ecology and synthetic approaches will become important in the future.

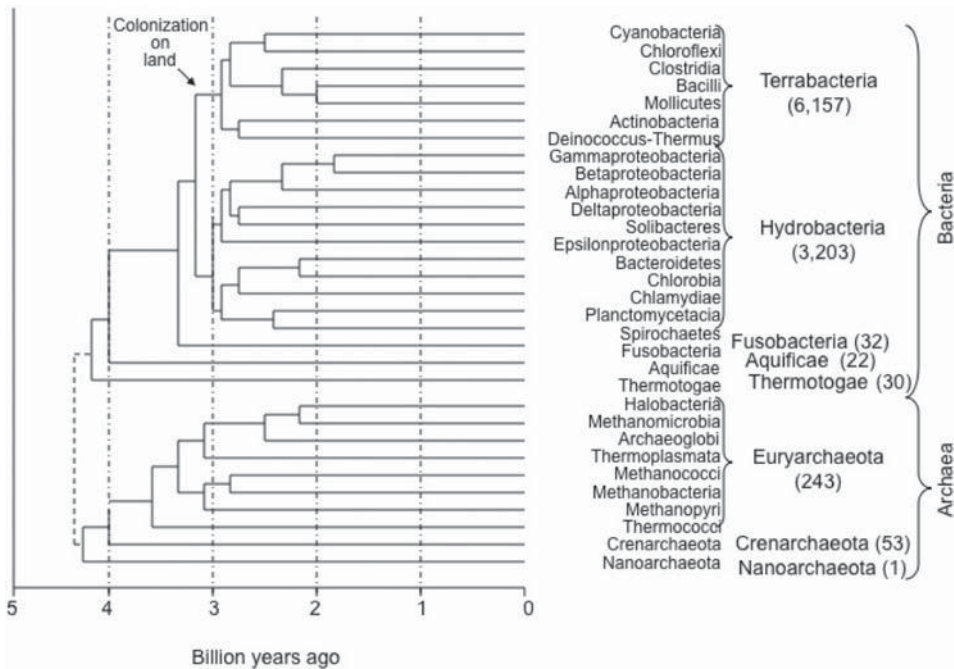
### 1.10.2 Diversity: From Culturing to Molecular Phylogeny

For many decades microbiology and the emerging field of microbial ecology relied on cultivation (Section 5.5) to identify microorganisms in the environment. This eventually led to the elucidation of what was called “the great plate count anomaly” (Section 5.2), in which researchers noticed the discrepancy in numbers between what they observed

TABLE 1.4. “Omic” Technologies with Applications to Microbial Ecology

Terms	Characteristics
Genomics	Analysis of gene content of an organism by sequencing and mapping of genomes (chromosomes of eukaryotes or nucleoid of prokaryotes)
Metagenomics	Analysis of gene content of all organisms in a specific environment
Transcriptomics	Study evaluating the production of mRNA produced at a specific time by a cultured organism
Proteomics	Study of protein structure and protein regulation of an organism
Metaproteomics	Analysis of all proteins produced by all the organisms in a specific environment
Metabionics	Study of small molecules and intermediate compounds produced from metabolism; frequently this includes the end products of metabolism
Metallomics	Study of the various metal ions and their activities in a biological cell
Biologics	Study of all the biological systems and biochemical components of cellular system
Microbiomics	Study including all the microorganisms and their interactions with the immediate environment.





**Figure 1.14.** Analysis of nucleic acid and protein sequences suggests importance of bacterial adaptation to life on land; numbers in parentheses indicate number of species of organisms in that group [modified from Battistuzzi and Hedges (2009)].

in the microscope versus what they could grow using standard media (less than 1% of microorganisms present in the environmental sample) (Staley and Konopka 1985). At about the same time, Carl Woese and Norm Pace were investigating the ability to identify and compare environmental organisms by their small-subunit ribosomal RNA genes, which provided a measure of evolutionary distance between organisms. This development revolutionized our view of the natural world and eventually, the classification of bacteria/archaea in the main reference work, *Bergey's Manual of Systematic Bacteriology*. Their efforts and subsequent studies revealed an amazing level of diversity in the microbial world.

## 1.11 SUMMARY

With respect to early life on Earth, there are two distinct activities: genesis of life and evolution of organisms. While scientists provide insightful discussions on these activities, new theories and past observations continue to attract the attention of microbiologists. The fossil record for bacteria is limited primarily to cyanobacteria and related microorganisms found in fossilized stromatolites. As an alternate to evaluation of available fossils, microbiologists rely on life-related processes consistent with the geologic record of Earth. Physiological process of  $O_2$  release from photosynthesis was an important activity of early life, and it can be concluded that bacteria with these metabolic capabilities were

present early in cellular evolution. Once cellular life was achieved, evolutionary development proceeded along several avenues, including the survival strategies as outlined by Darwin. The genetic design of prokaryotic organisms enabled bacteria and archaea to use horizontal gene flow in the generation of new species. Eukaryotic cells evolved with internal organelles developed from endosymbiosis of bacteria and genes from both bacteria and archaea. The tree of life as described by Woese serves to provide a structure for cellular evolution and establishes the dominant presence of bacteria and archaea in evolution of life on Earth. As new species of bacteria and archaea present in the environment are discovered, the picture becomes more complete with respect to prokaryote life, and with new computer programs (software) developed to evaluate molecular trees, the tree of life in the future is sure to become more detailed and will change to reflect newer information.

### 1.12 DELVING DEEPER: CRITICAL THINKING QUESTIONS

1. What is the evidence that the first forms of life were prokaryotes?
2. Describe some of the hypothesis for evolution of eukaryotes.
3. What evidence is there that bacteria are evolving today?
4. What evidence is there to suggest that bacteria did not evolve from archaea?
5. Why is it difficult to describe a species in microbiological terms?
6. What are some benefits in studying microbial ecology along with general ecology?
7. What are some limitations of the molecular techniques in evaluating microbial ecology? What are some areas for future development of new techniques for studying microbial ecology?
8. What is an ecotype? Compare and contrast this concept with that of a microbial species.
9. Describe several situations where it is desirable for microorganisms to respond to stimuli in the environment.
10. Why does the traditional biological species concept not work for defining a bacterial species?
11. In what ways can the identification of a theoretical basis for how microorganisms interact with each other and their environment help human society?

### BIBLIOGRAPHIC MATERIAL

#### Further Reading

- Blackmond DG (2009), An examination of autocatalytic cycles in the chemistry of proposed primordial reactions, *Angew. Chem. Int. Ed.* **48**:386–390.
- Cavalier-Smith T (2000), Membrane heredity and early chloroplast evolution, *Trends Plant Sci.* **5**:174–182.
- Ehrlich HL (2002), *Geomicrobiology*, 4th ed., New York: Marcel Dekker.

- Koeppel A, Perry EB, Sikorski J, Krizanc D, Warner A, Ward DM, Rooney AP, Brambilla E, Connor N, Ratcliff RM, Nevo E, Cohan FM (2008), Identifying the fundamental units of bacterial diversity: A paradigm shift to incorporate ecology into bacterial systematics, *Proc. Natl. Acad. Sci. (USA)* **105**:2504–2509.
- Margulis L (1982), *Early Life*, Boston: Science Books International.
- Miller RV, Day MJ, eds. (2004), *Microbial Evolution: Gene Establishment, Survival, and Exchange*, Washington, DC: ASM Press.
- Staley JT (2009), The phylogenomic species concept for bacteria and archaea, *Microbe* **8**:361–365.
- Wächterhäuser G (2000), Origin of life: Life as we don't know it, *Science* **289**:1307–1308.
- Winans SC, Bassler BL (2008), *Chemical Communication among Bacteria*, Washington, DC: ASM Press.
- Woese CR (1987), Bacterial evolution, *Microbiol. Rev.* **51**:221–271.

### Cited References

- Battistuzzi FU, Hedges SB (2009), A major clade of prokaryotes with ancient adaptations to life on land, *Molec. Biol. Evol.* **26**:335–343.
- Brock TD (1961), *Milestones in Microbiology*, Englewood Cliffs, NJ: Prentice-Hall.
- Canfield DE, Rosing MT, Bjerrum C (2006), Early anaerobic metabolisms, *Philos. Trans. Roy. Soc. Lond. B Biol. Sci.* **361**:1819–1836.
- Ciccarelli FD, Doerks T, von Mering C, Creevey CJ, Snel B, Bork P (2006), Toward automatic reconstruction of a highly resolved tree of life, *Science* **311**:1283–1287.
- Cohan FM, Perry EB (2007), A systematics for discovering the fundamental units of bacterial diversity, *Curr. Biol.* **17**: R373–R386.
- Curtin C (2009), Humans as host, *Genome Technol.* **95**:38–43.
- Deamer DW (1997), The first living systems: A bioenergetic perspective, *Microbiol. Molec. Biol. Rev.* **61**:239–261.
- Falkowski PG, Fenchel T, Delong EF (2008), The microbial engines that drive Earth's biogeochemical cycles, *Science* **320**:1034–1039.
- Fani R, Fondi M (2009), Origin and evolution of metabolic pathways, *Physics Life Rev.* **6**:23–52.
- Fondi M, Emiliani G, Fani R (2009), Origin and evolution of operons and metabolic pathways, *Res. Microbiol.* **160**:502–512. DOI: 10.1016/j.resmic.2009.05.001.
- Imbrie J, Hayes DJ, Martinson DG, McIntyre A, Mix AC, Morley JJ, Pisias NG, Prell WL, Shackleton NJ (1984), Temperature data using fossil plankton, in Berger A, Imbrie J, Hays J, Kukla G, Saltzman B, eds., *Milankovitch and Climate*, Dordrecht: Reidel, pp. 269–305.
- Jensen RA (1976), Enzyme recruitment in evolution of new function, *Annu. Rev. Microbiol.* **30**:409–425.
- Jessup CM, Kassen R, Forde SE, Kerr B, Buckling A, Rainey PB, Bohannan BJM (2004), Big questions, small worlds: Microbial model systems in ecology, *Trends Ecol. Evol.* **19**:189–197.
- Koch AL (1985), Primeval cells: Possible energy-generating and cell-division mechanisms, *J. Molec. Evol.* **21**:270–277.
- Koch AL, Silver S (2005), The first cell, *Adv. Microbial Physiol.* **50**:227–260.
- Konhauser K (2007), *Introduction to Geomicrobiology*, Oxford, UK: Blackwell.
- Landström O, Christell R, Koski K (1983), Field experiments on the application of neutron activation techniques to in situ borehole analysis, *Geoexploration* **10**:23–39.
- Lartigue C, Vashee S, Algire M, Chuang R-Y, Benders GA, Ma L, Noskov VN, Denisova EA, Gibson DG, Assad-Garcia N, Alperovich N, Thomas DW, Merryman C, Hutchison III CA,

- Smith HO, Venter JC, Glass JI (2009), Creating bacterial strains from genomes that have been cloned and engineered in yeast, *Science* **325**:1693–1696.
- Lechevalier HA, Solotorovsky M (1965), *Three Centuries of Microbiology*, New York: McGraw-Hill.
- Madigan MT, Martinko JM, Dunlap PV, Clark DP (2009), *Brock Biology of Microorganisms*, 12th ed., San Francisco: Pearson Benjamin Cummings.
- Margulis L, Schwartz KV (1998), *Five Kingdoms: An Illustrated Guide to the Phyla of Life on Earth*, 3rd ed., New York: Freeman.
- Pace NR (1997), A molecular view of microbial diversity and the biosphere, *Science* **276**:734–740.
- Prosser JI, Bohannan BJM, Curtis TP, Ellis RJ, Firestone MK, Freckleton RP, Green JL, Green LE, Killham K, Lennon JJ, Osborn AM, Solan M, van der Gast CJ, Young JPW (2007), The role of ecological theory in microbial ecology, *Nature Microbiol. Rev.* **5**:384–392.
- Rasmussen B, Blake TS, Fletcher IR, Kilburn MR (2009), Evidence for microbial life in synsedimentary cavities from 2.75 Ga terrestrial environments, *Geology* **37**:423–426.
- Rasmussen B, Fletcher IR, Brooks JJ, Kilburn MR (2008), Reassessing the first appearance of eukaryotes and cyanobacteria, *Nature* **1038**:1101–1104.
- Schlegel HG, Köhler W (1999), Bacteriology paved the way to cell biology: A historical account, in Lengeler JW, Drews G, Schlegel HG, eds., *Biology of the Prokaryotes*, Oxford, UK: Blackwell Science, pp. 1–19.
- Schopf JW (1993), Microfossils of the early Archean Apex chert: New evidence of the antiquity of life, *Science* **260**:640–646.
- Sleytr UB, Messer P, Pum D, Sára M (1996), *Crystalline Bacterial Cell Surface Proteins*, Georgetown, TX: R. G. Landes Company.
- Smith KF, Dobson AP, McKensie FE, Real LA, Smith DL, Wilson ML (2005), Ecological theory to enhance infectious disease control and public health policy, *Frontiers Ecol. Environ.* **3**:29–37.
- Staley JT, Konopa A (1985), Measurement of in situ activities of nonphotosynthetic microorganisms in aquatic and terrestrial habitats, *Annu. Rev. Microbiol.* **39**:321–346.
- Staley JT, Gunsalus RP, Lory S, Perry JJ (2007), *Microbial Life*, 2nd ed., Sutherland, MA: Sinauer Associates, Inc.
- Stetter KO (2006), Hyperthermophiles in the history of life, *Phil. Trans. R Soc. B* **361**:1837–1843.
- Wächtershäuser G (1990), Evolution of the first metabolic cycles, *Proc. Natl. Acad. Sci. (USA)* **87**:200–204.
- Whitman WB, Coleman DC, Wiebe WJ (1998), Prokaryotes: The unseen majority, *Proc. Natl. Acad. Sci. (USA)* **95**:6578–6583.
- Williams RJP, Fraústo da Silva JJR (2006), *The Chemistry of Evolution: The Development of Our Ecosystem*, London: Elsevier.
- Woese CR, Fox GE (1977), Phylogenic structure of the prokaryotic domain: The primary kingdoms, *Proc. Natl. Acad. Sci. (USA)* **74**:5088–5909.
- Woese CR, Kandler O, Wheelis ML (1990), Towards a natural system of organisms: Proposal for the domains Archaea, Bacteria, and Eucarya, *Proc. Natl. Acad. Sci. (USA)* **87**:4576–4579.
- Ycas M (1974), On earlier states of the biochemical system, *J. Theor. Biol.* **44**:145–160.

## Internet Sources

<http://www.microbeworld.org>

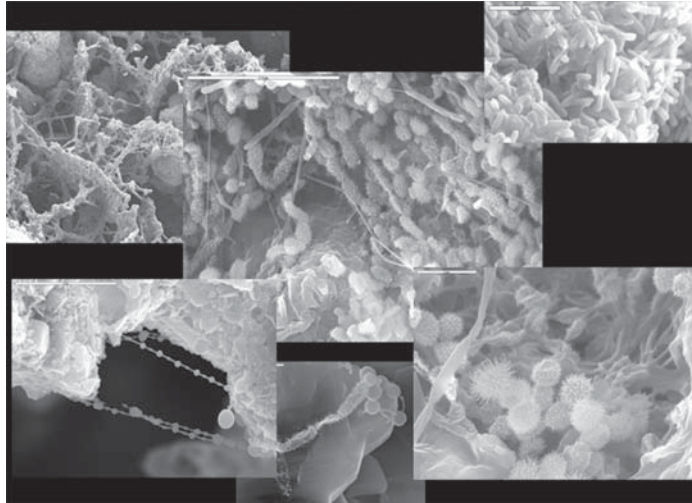
# DIVERSITY OF MICROORGANISMS

## 2.1 CENTRAL THEMES

- Think of a habitat on Earth, and you'll find microorganisms there—they are almost ubiquitous.
- The microbial world includes bacteria, archaea, algae, protozoa, fungi, and viruses.
- Microbial diversity is measured by increasingly sophisticated methods.
- Our knowledge of the diversity of microorganisms has grown substantially since the 1970s. For example, the diversity of bacterial phyla has grown from 11 in 1987 to 52 in 2003 to possibly more than a 100 phyla today.
- Across the range of microorganisms, from bacteria to algae, there are some common shapes, such as spheroidal cocci, filaments, and rod or bacillus shapes. Beyond these commonalities are many varied morphologies (Figure 2.1).

## 2.2 THE UBIQUITY OF MICROORGANISMS

Microbiology was dominated by the study of microorganisms associated with diseases for many decades, but the discovery of incredible microbial life at deep-sea vents and



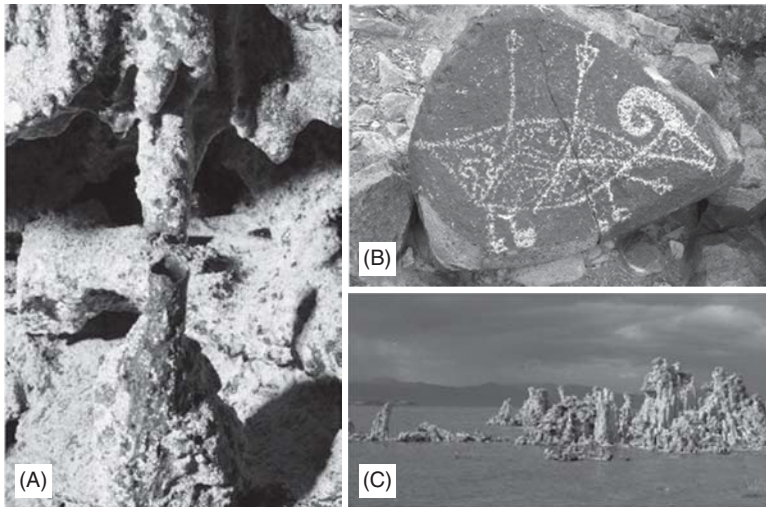
**Figure 2.1.** A variety of morphologies exists in the natural world. These scanning electron micrographs represent microorganisms found in samples from ferromanganese deposits and cave microbial mats. (Photomicrographs courtesy of Michael Spilde and Diana Northup.)

in other habitats changed our view of where microorganisms live. This has led to the study of what are termed *extremophiles*. Studies have shown that bacteria and archaea live in extremely hot environments (hot springs and deep-sea hydrothermal vents), up to 121°C (hyperthermophiles) and in very cold temperatures in the permafrost, down to -20°C (psychrophiles). They can live in very salty environments such as salterns and the Dead Sea (halophiles), and in very acidic and alkaline environments, such as acid mine drainage and playa lakes (acidophiles or alkaliphiles). They can also live in environments previously thought to be devoid of life, such as the extreme habitat of the Atacama Desert and on the surfaces of rocks, such as the cave formations and petroglyphs seen in Figure 2.2. In fact, there are very few environments in which life has not been found, and Chapter 4 addresses different microbial habitats.

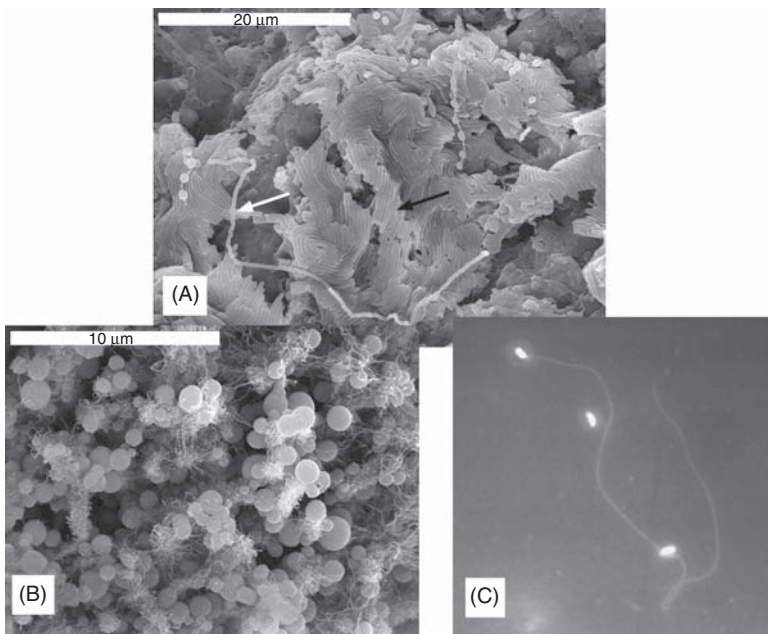
### 2.3 THE AMAZING DIVERSITY OF MORPHOLOGIES

Although we do not base bacterial and archaeal taxonomy on morphology because of the predominance of a few common shapes (Figure 2.3), several bacteria and archaea do come in a variety of morphotypes. Round (cocci), rod, filamentous, and comma or vibrio shapes are some of the most commonly observed morphologies. Young (2007) has postulated that bacterial morphology is shaped by evolution and that different shapes help bacteria find food, attach to surfaces, escape predators, move through their environments, and divide. Bacteria can modify their shape to better adapt to their environment. Thus, while some bacterial/archaeal shapes may be diagnostic to humans, such as Walsby's square "bacterium" seen in Figure 2.12, most have less informative shapes that help bacteria and archaea utilize their environments most effectively.





**Figure 2.2.** (A) Microbial mats line the walls and formations of a lava tube on Terceria, Azores, Portugal; (B) rock environments, such as the varnish into which this petroglyph is carved in Three Rivers Petroglyph National Monument, NM (USA), harbor microorganisms; (C) the highly alkaline environment of Mono Lake, CA (USA). (Photos courtesy of Kenneth Ingham.) See insert for color representation.



**Figure 2.3.** (A) Filaments (long, slender spaghetti-like shape, white arrow) and rods (shorter, cigar-shaped morphology, e.g., black arrow) from a microbial mat on the walls and formations of a lava tube on Terceria, Azores, Portugal (scale bar 20  $\mu\text{m}$ ); (B) coccoid (round) bacteria observed in microbial mats from the walls and formations of a lava tube on Terceria, Azores, Portugal (scale bar 10  $\mu\text{m}$ ); (C) prosthecae bacteria have appendages called *prosthecae* that they use to attach to surfaces and to take up nutrients. Field of view is approximately 60  $\mu\text{m}$  in diameter.

### 2.3.1 Comparison of the Three Domains

Fundamental differences, as well as similarities, occur among the three domains Eukarya, Archaea, and Bacteria (Table 2.1). These similarities and differences have helped decipher the relative position of the three domains to each other in the tree of life.

### 2.3.2 What's in a Name: Prokaryotes

Norman R. Pace has challenged the use of the word *prokaryote* to describe organisms that lack a membrane-bound nucleus as opposed to eukaryote, which denotes organisms that do have a membrane-bound nucleus. This article, which appeared in the journal *Nature* (Pace 2006), has fueled a rebuttal and discussions about the three-domain tree of life. Pace argues that, based on the three-domain tree of life (see Figure 2.4), the Bacteria and Archaea do not group together as a monophyletic group; rather than there being two kinds of organisms, prokaryote and eukaryote, there are three: Eukarya, Bacteria, and Archaea. He also argues that the definition of prokaryote is a negative one (i.e., defining what prokaryotes are not), and argues that: "I believe it is critical to shake loose from prokaryote/eukaryote concept. It is outdated, a guesswork solution to an articulation of biological diversity and an incorrect model for the course of evolution."

Martin and Koonin (2006), in a rebuttal, offer the positive definition of prokaryotes as "organisms that co-transcriptionally translate their main chromosomes." What this debate highlights is our changing view of the very nature of life and how we view and classify organisms. Read the two papers and think about where you stand on this debate.

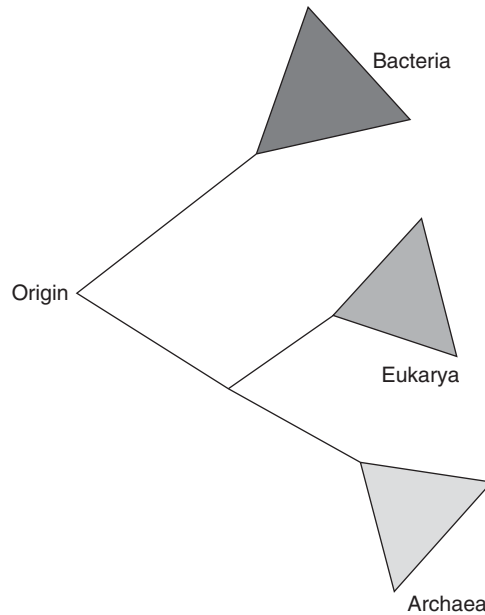
### 2.3.3 Winogradsky's Experiments with Chemolithotrophs

Not all early microbiology studies concentrated on disease-associated microorganisms. One early microbiologist, Sergei Winogradsky, pioneered work with chemolithotrophs

TABLE 2.1. Similarities and Differences: Eukarya, Archaea, Bacteria

	Eukarya	Archaea	Bacteria
Cell wall	No peptidoglycan, many different forms	Glycoprotein, protein, pseudomurein, wall-less	Lipopolysaccharide and murein, protein, cell wall-less (few)
Cytoplasm membrane	Glycerol esters of fatty acids	Glycerol ethers of isoprenoids	Glycerol esters of fatty acids
Genetic material	Nucleus with more than one linear chromosome, histones present	Circular chromosome, plasmids and viruses, histones present	Circular chromosome plasmids and viruses, no histones
RNA polymerases	3 (12–14 subunits)	1 (8–12 subunits)	1 (4 subunits)
Transcription factors required?	Yes	Yes	No
Chloramphenicol, streptomycin, kanamycin sensitivity	No	No	Yes





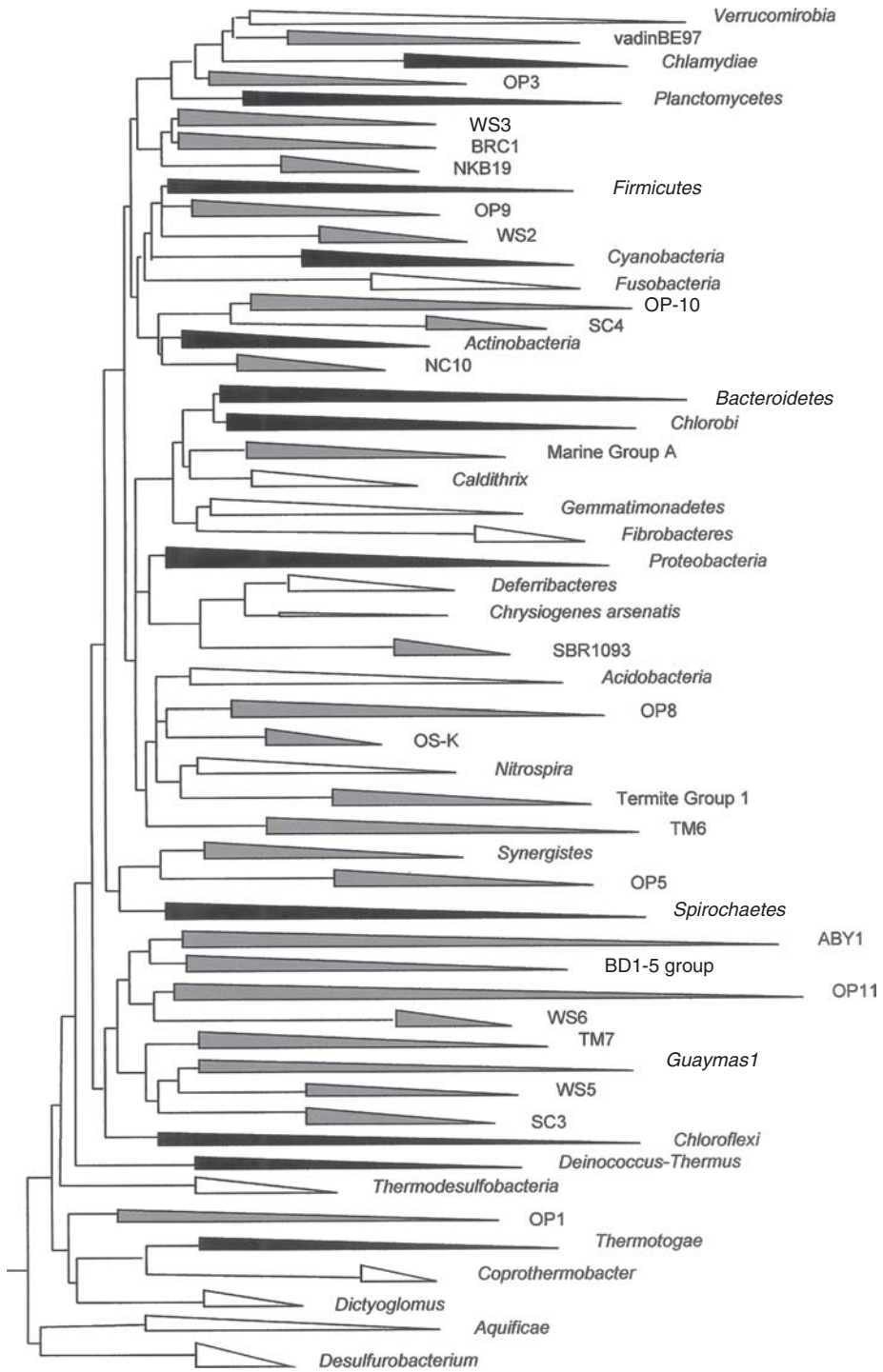
**Figure 2.4.** The tree of life is divided into three domains in which Archaea are believed to be phylogenetically closer to Eukarya than to Bacteria [modified from Pace (2006)].

in the late 1800s, and described the concept of chemolithotrophy from his studies of sulfur-oxidizing bacteria. From his research on ammonia-oxidizing bacteria he described and named *chemoautotrophy*, the process in which organisms utilize carbon dioxide as their source of carbon. In his experiments that led to the discovery of chemolithotrophs, he created what has become known as the *Winogradsky column*, in which he created a gradient of anoxic and oxic environments, using tightly packed mud containing organic carbon sources and sulfide, covered with water from a natural source. As the column developed under diffuse sunlight, a rich community of aerobic organisms developed at the top and an anaerobic community, including sulfate-reducing bacteria, developed in the mud at the bottom. These experiments enabled Winogradsky to identify a wide range of species and processes. Such experiments have led to important breakthroughs in our understanding of the natural world.

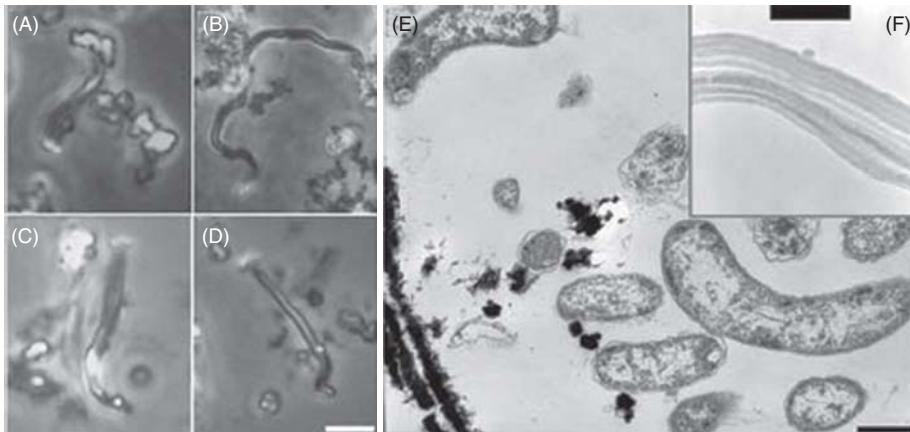
## 2.4 DIVERSITY OF BACTERIAL GROUPS

### 2.4.1 Expansion of the Number of Bacterial Phyla

Our knowledge of the diversity of bacteria has made substantial leaps since the 1980s, from the 11 phyla in Woese (1987) to the approximately 36 phyla (Hugenholtz et al. 1998; Hugenholtz 2002) to the 52 phyla identified by Rappé and Giovannoni (2003). The original 11 phyla of Woese (in black, Figure 2.5) have changed some as the Gram positives have been split into Actinobacteria and the Firmicutes. Phyla shown in white (Figure 2.5) represent phyla with at least one cultivated member. Contrast this with the



**Figure 2.5.** Fifty-two bacterial phyla depicted in Rappé and Giovannoni (2003). Black blocks represent the original 11 phyla (one of which was split into two phyla); white blocks represent phyla with at least one cultivated member; gray blocks represent phyla with no cultivated members.



**Figure 2.6.** (A–D) Cells of *Mariprofundus ferrooxydans*, a newly described member of the *Zetaproteobacteria*, adhering to glass slides (scale bar 5  $\mu\text{m}$ ); (E): TEM image showing Gram-negative cell wall and iron oxides (lower left); (F) closeup of the fibers that make up the iron oxide filament. [From Emerson et al. (2007), public domain.]

number of phyla (gray) that include no cultivated members and are known from genetic sequences. These phyla represent half of those in the study by Rappé and Giovannoni (2003) and indicate the inadequacy of our knowledge of the Domain Bacteria. By all indications, the number of phyla within the bacterial domain will continue to increase as more environments are explored using molecular techniques.

The diversity of the Domain Bacteria is vast. In this section, we will highlight some of this diversity within the Bacteria. Diversity within the Bacteria encompasses phylogeny, reproduction, metabolic lifestyle, morphology, and other factors. We'll begin with some of the more familiar members and move to some of the newer, more exotic members. Notice the range of diversity in the factors mentioned above as you read through these bacterial portraits.

## 2.4.2 Bacterial Portrait Gallery: Processes and Players

**Phototrophs: Critical Ecosystem Players.** Photosynthesis is critical to life on Earth, and many microorganisms are phototrophic. Five bacterial phyla contain phototrophs: Firmicutes, Proteobacteria, Chloroflexi, Cyanobacteria, and Chlorobi, all of which utilize photochemical reaction centers (a complex of proteins in which energy from the sun is converted in a series of electron transfer reactions). Presently, all members of the latter two phyla are known to be primarily phototrophs. Members of the Chlorobi, also known as *green sulfur bacteria*, are obligate anaerobic photoautotrophs that oxidize sulfur compounds, reduced iron, or hydrogen and have a type 1 reaction center and light-harvesting protein, Fenna–Matthews–Olson (FMO), for photosynthesis (Bryant and Frigaard 2006). A discovery at a black smoker in the East Pacific Rise led to the cultivation of GSB1, a green sulfur bacterium that can grow phototrophically on the geochemical light from the vent, where it was captured in the vent effluent. This, and other discoveries at vents, show that photosynthesis can be powered by light other than sunlight (Beatty et al. 2005). Another one of the original 11 bacterial phyla, Cyanobacteria, are an old and diverse

phylum that contains the oxygen-evolving photosynthetic bacteria. They have type 1 and 2 reaction centers and use the Calvin–Benson–Bassham cycle to reduce carbon dioxide. Light is gathered by light-harvesting antennae, mostly phycobilisomes, in Cyanobacteria.

The other three phyla that contain phototrophs—Firmicutes, Proteobacteria, and Chloroflexi—vary in the diversity of phototrophic organisms and in the mechanisms used. Not all phototrophic bacteria fix carbon dioxide and are therefore not photosynthetic (Bryant and Frigaard 2006). Within the Chloroflexi, a group of filamentous, gliding bacteria, perform anoxygenic (no production of oxygen) photosynthesis. Subdivisions  $\alpha$ ,  $\gamma$ , and  $\beta$  of the Proteobacteria harbor photosynthetic bacteria that are metabolically diverse, and some members are facultatively phototrophic. More recently, members of the Heliobacteriaceae, within the Firmicutes, have been shown to contain reaction centers. As genomic studies proceed on a diverse array of members of these five phyla, many new insights into the evolution of photosynthesis are likely to be made.

**A New Discovery in One of the Original Eleven: Zetaproteobacteria.** Novel classes can still be discovered within phyla that have been known for decades, as evidenced by the discovery of the Zetaproteobacteria by Emerson et al. (2007). These curved rods, cultured from the Loihi Seamount, form “filamentous stalk-like structures of iron oxyhydroxides” during their growth (see Figure 2.6). Named *Mariprofundus ferrooxydans* gen. nov., sp. nov., these microaerophilic bacteria grow exclusively on reduced iron with carbon dioxide as their sole carbon source, between pH 5.5 and 7.2. *Mariprofundus ferrooxydans* exhibits a new ability: the ability to grow on Fe<sup>0</sup> metal. Phylogenetically, *M. ferrooxydans* branches deeply within the Proteobacteria, and Emerson et al. (2007) have proposed that it represents a new candidatus class, the Zetaproteobacteria. Thus, even within the old and familiar phyla, new discoveries are being made.

**Aquificales: Some Like It Very Hot!** Thermophilic organisms are found not just within the Archaea but also within the Bacteria. The phylum Aquificae, which branches deeply within the Bacteria, contains the most thermophilic bacterial genus, *Aquifex*, an obligate chemolithoautotrophic bacterium. As electron donors, *Aquifex* uses sulfur, hydrogen, or thiosulfate, and uses either nitrate or oxygen as electron acceptors. Aquificales are some of the few microaerophilic thermophiles known. Both marine (shallow and deep-sea vents) and terrestrial hydrothermal systems are ideal habitats for *Aquifex* and other Aquificales, which thrive at an optimum temperature of around 85°C. Studies are ongoing to determine how deeply the Aquificae branch within the Bacteria and to resolve relationships within the phylum (Ferrera et al. 2007). Some theories of the origin of life suggest that early life was thermophilic and used reduced substrates such as hydrogen. Organisms such as the Aquificae that are thermophilic and utilize hydrogen may shed light on lifestyles on early Earth.

**Nitrogen-Fixing Bacteria.** Without a doubt, the nitrogen-fixing bacteria are some of the most important bacteria ecologically (Table 2.2). Nitrogen fixing bacteria can be free-living, or can form symbiotic relationships with plants (see Section 7.6.1). Although energetically expensive, this process is critical for supplying nitrogen for growth needs for a wide range of organisms, including plants and other microorganisms. Nitrogen-fixing bacteria can participate in obligate or facultative symbioses with a wide variety of eukaryotic hosts across the animals, fungi, and plants. The diversity of nitrogen-fixing bacteria is extensive and spans the cyanobacteria, four subdivisions of the proteobacteria, actinobacteria,

TABLE 2.2. Examples of Nitrogen-Fixing Bacteria

Phyla	Example Genus	Host If Symbiotic
Cyanobacteria	<i>Nostoc</i>	Bryophytes
	<i>Anabaena</i>	Pteridophytes
	<i>Trichodesmium</i>	Gymnosperms (cycads)
	<i>Synechococcus</i>	Angiosperms ( <i>Gunnera</i> )
	<i>Cyanothece</i>	Fungi (cyanolichens), diatoms, sponges
Actinobacteria	<i>Frankia</i>	Actinorhizal plants
Proteobacteria	$\alpha$ : <i>Sinorhizobium</i> , <i>Mesorhizobium</i>	Legumes
Proteobacteria	$\beta$ : <i>Azoarcus</i> , <i>Burkholderia</i>	Legumes
Proteobacteria	$\gamma$ : <i>Azotobacter</i> , <i>Pseudomonas</i>	Legumes
Proteobacteria	$\delta$ : <i>Gloeobacter</i> , <i>Desulfovibrio</i>	AM Fungi
Firmicutes	<i>Clostridium</i>	
Bacteroidetes/Chlorobiales	<i>Chlorobium</i>	
Spirochaetales	<i>Treponema</i>	Termites
Chloroflexi	<i>Dehalococcoides</i>	

Source: Modified from Kneip et al. (2007).

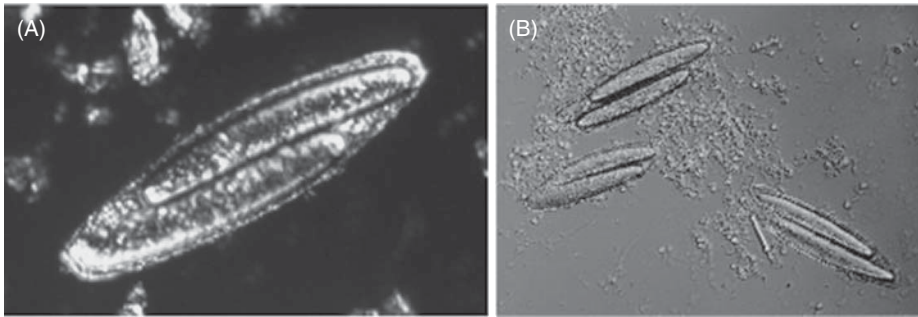
firmicutes, Chromatiales (purple sulfur bacteria), Chlorobiales (green sulfur bacteria), and spirochetes (Kneip et al. 2007).

One example of a symbiotic relationship of nitrogen-fixing bacteria is that found in termite guts. It has been known for a long time that spirochetes inhabit termite hindguts, but more recent discoveries have shown that the spirochetes fix nitrogen, providing this key resource to their hosts (see Section 8.5.1). *Trichonympha agilis*, a termite gut-inhabiting flagellate, contains an intracellular symbiotic bacterium that fixes nitrogen. These two examples illustrate a free-living nitrogen fixer (spirochete) and an obligate symbiotic nitrogen fixer.

The cyanobacterial partner in the lichen symbiosis (Section 6.4.2) brings nitrogen-fixing abilities to the partnership, as well as photosynthetic capabilities. Cyanobacteria, such as *Nostoc* spp. that live as symbiotic partners in lichens, have more heterocysts as symbionts than as free-living bacteria.

Interestingly, all nitrogen-fixing bacteria use the same enzymatic reaction, based on the nitrogenase enzyme complex, in a wide variety of symbiotic relationships that provide eukaryotes with the key element, nitrogen. These symbioses in plants are key to our agricultural success and therefore can have large economic impacts. At least 44 legume species in 12 genera have symbiotic nitrogen-fixing bacteria (Sawada et al. 2003). Additionally, nitrogen-fixing bacteria illustrate several important ecological concepts: a range of obligate to facultative symbiotic mutualisms across many eukaryotic groups, nutrient cycling (i.e., nitrogen), widespread diversity, and the importance of microorganisms in the ecosystem. These concepts will be developed in later chapters.

**Epulopiscium: A Case of Extreme Polyploidy.** One of the largest bacteria known, *Epulopiscium* spp., some of the largest bacteria known, occur as symbionts of surgeonfish and are famous for their size (>600  $\mu\text{m}$ ; see Section 3.3.2.) and mode of reproduction. This cigar-shaped bacterium reproduces multiple offspring intracellularly, a phenomenon that Angert (2005) suggests evolved from endospore production (see Figure 2.7). Cell



**Figure 2.7.** (A,B) *Epulopiscium fishelsoni* (photos courtesy of Esther Angert). See insert for color representation.

division within the mother cell results in several intracellular daughter cells; both mother and daughter cells grow until a point at which the daughter cell pulls ahead and eventually the mother cell disintegrates, allowing daughter cells to emerge.

*Epulopiscium*'s size presents a problem to the bacterium. Many bacteria are small in size in order to increase their access to environmental nutrients. If your surface-to-volume ratio is high, then most of your cytoplasm is always close to the source of the nutrients, and diffusion is an effective tool for distribution of needed resources (see Box 3.1). So, if you're really big, as *Epulopiscium* is, what do you do to solve this problem? In an ingenious piece of detective work, Angert and colleagues (Mendell et al. 2008) have discovered that *Epulopiscium* maintains extreme polyploidy throughout its life and has tens of thousands of genome copies in each individual, which line the cell periphery. Thus, a *Epulopiscium* cell has genomes strategically located to respond to local stimuli, overcoming the problems of large cell size. Their research also reveals that genome copy number correlates linearly with cytoplasmic volume. Mendell et al. (2008) suggest that the observed extreme polyploidy may have evolved as part of the symbiosis with the surgeonfish; larger *Epulopiscium* cells are able to move more efficiently within the gut to feed and also are able to escape ciliate predation more effectively. The discovery of "long mononucleotide tracts" in the *dnaA* gene, an essential gene in *Epulopiscium*, suggests another evolutionary advantage. Such a phenomenon is rare in bacterial/archaeal genomes, but common in eukaryotes. *Epulopiscium*'s extreme polyploidy may support the occurrence of the unstable long mononucleotide tract without harm to the cell. Polyploidy is not unknown in bacteria, but has never been observed before on this scale. Investigation of the evolutionary significance of this phenomenon promises new insights.

## 2.5 DISCOVERY OF ARCHAEA AS A SEPARATE DOMAIN

What are the roots of the discovery of the *Archaea*? Woese and Fox (1977) stated:

The biologist has customarily structured his world in terms of certain basic dichotomies. Classically, what was not plant was animal. The discovery that bacteria, which initially had been considered plants, resembled both plants and animals less than plants and animals resembled one another led to a reformulation of the issue in terms of a yet more basic dichotomy, that of eukaryote versus prokaryote.



Thus began their paper that identified three major lines of descent that encompassed all living organisms, which included the separate division that they proposed to call the archaeobacteria, which we now term the *Archaea*: “There exists a third kingdom which, to date, is represented solely by the methanogenic bacteria . . . These ‘bacteria’ appear to be no more related to typical bacteria than they are to eukaryotic cytoplasm.”

It’s fascinating to look back in time over the shoulders of the scientists who described the methanogens as a separate domain of life and forever changed our view of the living world. Woese and Fox (1977) went on to predict that additional domains would not be discovered. To date, their prediction has been borne out. Although known at the time, the halophiles were not included in the newly suggested archaeobacterial domain.

## 2.6 ARCHAEAL DIVERSITY

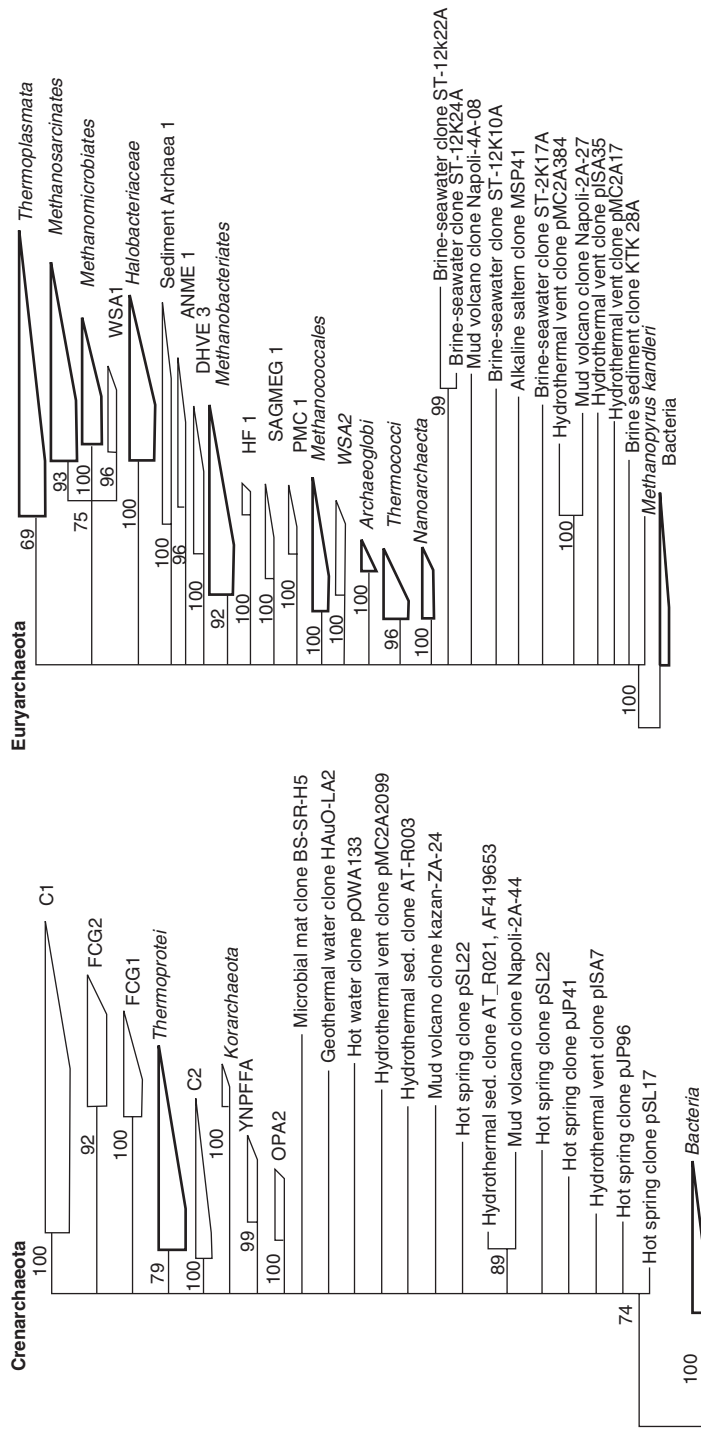
During the 1970s, early phylogenetic trees of the Archaea showed two phyla: the Crenarchaeota and the Euryarchaeota. These trees were based on cultivated archaeal members and presented the Archaea as extremophiles that lived in high-temperature and high-salt environments or generated methane (i.e., methanogens). Beginning in the early to mid-1990s, environmental archaeal sequences in GenBank began to grow exponentially, and the archaeal tree of life changed from an extremophile tree to a much more diverse tree (Robertson et al. 2005). More than three-quarters of GenBank archaeal sequences are now uncultured, environmental isolates, from an amazing array of habitats, including the ocean, human mouths, the rhizosphere, caves, and lakes. The Crenarchaeota and the Euryarchaeota phyla differ dramatically in terms of the number of cultured members, as seen in Figure 2.8. This lack of cultivated crenarchaeotal species has greatly hampered our knowledge of the roles that these organisms play in the ecosystem.

The division of the Archaea into the Crenarchaeota and the Euryarchaeota phyla was formally proposed in Woese et al. (1990). Since that time, many attempts have been made to produce a robust phylogenetic tree of the Archaea (Robertson et al. 2005; Schleper et al. 2005) and additional phyla have been proposed, but most of these attempts failed to adequately resolve the deep branches of the tree. A new attempt to resolve relationships within the Archaea and shed light on the divergence of the mesophilic and hyperthermophilic crenarchaeota has led to the more recently proposed third archaeal phylum, the Thaumarchaeota, which encompasses the currently identified mesophilic archaea (Brochier-Armanet et al. 2008).

Because of the dearth of cultured Archaea, we know little about their metabolic capabilities and lifestyles. We have evidence that hydrogen-based metabolism is a common theme, that some archaeal ecotypes are chemoorganotrophs, and that archaea play important roles in nitrogen (especially nitrification) and carbon cycling [reviewed in Aller and Kemp (2008); Brochier-Armanet et al. (2008), and Robertson et al. (2005)]. Although archaea have been found to be associated with gum disease in humans, in general they have not been found to cause disease, unlike their bacterial associates. Whether this is due to our lack of success in culturing mesophilic archaea or some innate characteristic such as their membranes is currently unknown (Allers and Meverch 2005).

### 2.6.1 Archaeal Portrait Gallery

The Domain Archaea contains many well-known species within the methanogens, halophiles, and thermophiles, but additional novel species are being discovered that



**Figure 2.8.** A contrasting view of the phylogenetic trees for *Crenarchaeota* and *Euryarchaeota* [modified from Robertson et al. (2005)].



expand our knowledge of environments in which the archaea are found and the processes by which they thrive in what humans view as hostile environments.

**Hyperthermophiles.** One of the charismatic microbiota, hyperthermophiles are quite numerous within the Archaea, especially within the Crenarchaeota, and they cluster around the base of the tree as short, deep phylogenetic branches. The first hyperthermophiles were described in the early 1980s, and now more than 34 genera across 10 orders within the Bacteria and Archaea have been identified that utilize a variety of electron acceptors and donors (Table 2.3) and that can be facultative heterotrophs. Hyperthermophiles are most often found in solfataric fields (soils or mud holes) that are often found in association with volcanoes; solfataric fields may have an abundance of pyrite or iron hydroxides, carbon dioxide, hydrogen sulfide, molecular hydrogen, and methane, essential substances for metabolic activities. Submarine hydrothermal systems and the deep-sea smoker vents are also important habitats for hyperthermophiles. Karl Stetter discovered two of the highest-temperature organisms: (1) *Pyrodictium occultum*, which grows at an upper temperature limit of 110°C, in the shallow, hot vents at Vulcano, Italy, and (2) *Pyrolobus fumarii*, which has an upper growth limit of 113°C and was isolated from a Mid-Atlantic Ridge black smoker wall. The latter will not even grow below 90°C! Stetter made an additional discovery of one of the smallest thermophiles ever found, *Nanoarchaeum equitans*, which is approximately 400 nm in diameter.

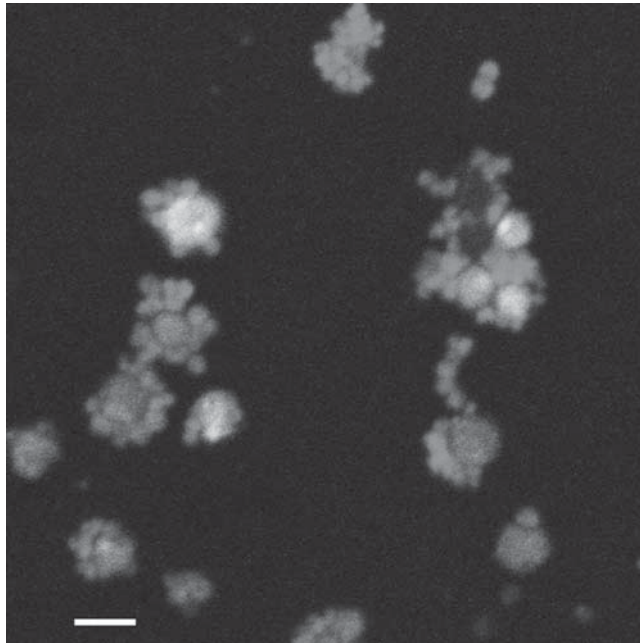
***Nanoarchaeum equitans*: A Dwarf, Thermophilic Archaeon.** Since Carl Woese proposed the domain Archaea, based on studies of methanogens, many new extremophiles have been discovered. During investigations of submarine vents, Huber et al. (2002) discovered a close association between a new species of *Ignicoccus* and a dwarf archaeon that they named *Nanoarchaeum equitans* [“riding the fire sphere” (Figure 2.9)]. This discovery represents one of the attempts to propose a new phylum within the Archaea, which Huber et al. (2002) named the *Nanoarchaeota* (“the dwarf archaea”). *Nanoarchaeum equitans* can be cultured only as a coculture with *Ignicoccus* and appears to require a “direct cell–cell contact,” which points to our inability to always achieve pure microbial cultures. Other interesting facets of this dwarf archaeon include its thermophilic lifestyle, as it grows at 70–98°C, and its tiny genome size of 0.5 megabases (Mb), making it one of the first possible symbiotic, dwarf thermophilic archaea to be discovered.

***Ferroplasma*: A Cell-Wall-Less, Iron-Oxidizing Archaeon.** Environmental studies are revealing many new and unusual species of Archaea, such as the discovery of the new

TABLE 2.3. Hyperthermophiles Live as Chemolithoautotrophs, Utilizing Various Major Energy-Yielding Reactions and Obtaining Carbon from Fixing Carbon Dioxide

Electron Donor	Electron Acceptor	Product
H <sub>2</sub>	CO <sub>2</sub>	Methane
	Fe(OH) <sub>3</sub>	Magnetite
	S <sup>0</sup> , SO <sub>4</sub> <sup>2-</sup>	Hydrogen sulfide
	NO <sub>3</sub> <sup>-</sup>	Nitrogen (ammonia)
	O <sub>2</sub> (trace)	Water
S <sup>0</sup> (pyrite)	O <sub>2</sub>	H <sub>2</sub> SO <sub>4</sub> (+FeSO <sub>4</sub> )

Source: Modified from Stetter (2006).

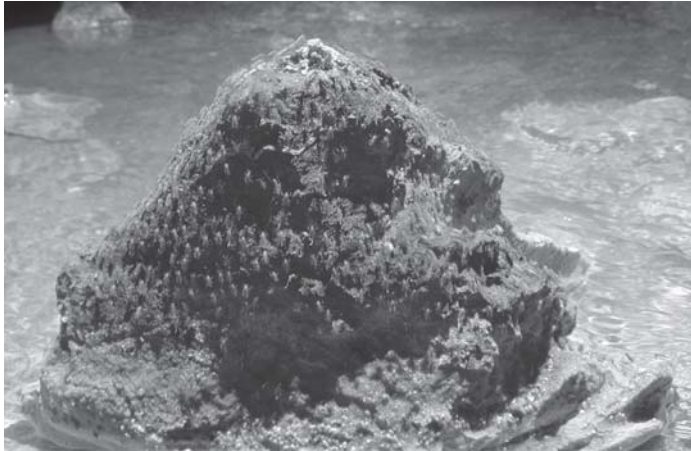


**Figure 2.9.** Fluorescent *in situ* hybridization (FISH) study of the dwarf archaea *Nanoarchaeum equitans* (red) closely associated with the larger spherical *Ignicoccus* (green). (Photo courtesy of Harald Huber.) See insert for color representation.

species *Ferroplasma acidiphilum*, often found associated with acidic sulfide ores, and cultured and described from a pyrite-leaching bioreactor [reviewed in Golyshina and Timmis (2005)]. *Ferroplasma* is most prevalent where there is abundant ferrous iron, heavy metals, and very acidic but stable conditions; it is often more prevalent in these conditions than are previously documented iron-oxidizing bacteria, such as *Acidithiobacillus* spp. and *Leptospirillum* spp. The intriguing facet of this archaeon, which is classified in the Thermoplasmatales within the Euryarchaeota, is its cell-wall-less nature in acidic environments. One of the authors documented the dominance of *Ferroplasma* in the archaeal portion of the community of green biofilms in total darkness in Cueva de Villa Luz, Tabasco, Mexico (see Figure 2.10).

The key to archaeal survival in very acidic conditions is their ability to maintain very low proton permeabilities, due to their tetraether lipids. *Ferroplasma* accomplishes this, even though it lacks a cell wall, with a new kind of tetraether lipid, a caldarchaetidylglycerol tetralipid with an isoprenoid core (Golyshina and Timmis 2005). Genomic analyses suggest that *Ferroplasma* spp. cycle iron and metabolize carbon and reveal the presence of several genes for resistance to various heavy metals. Research is also demonstrating that *Ferroplasma* spp. may be important in biomining, giving them an important biotechnology potential. By studying *Ferroplasma*, we can better understand how extremophiles are able to exist in what seem to us to be very hostile conditions.

**Methanogens.** Known for many years, but previously included with the bacteria in the Monera kingdom until Carl Woese proposed the Domain Archaea, methanogens now reside within the Euryarchaeota. Methanogens are the moderates of the archaea,



**Figure 2.10.** The archaeal portion of the microbial community of this green biofilm in the aphotic region of Cueva de Villa Luz, Mexico, is dominated by *Ferroplasma* spp.

**TABLE 2.4.** Examples of Methanogenesis Reactions and Their Resultant Changes in Free Energy

Reaction	$\Delta G^{\circ}$ (kJ/mol CH <sub>4</sub> )
$4 \text{ H}_2 + \text{CO}_2 \rightarrow \text{CH}_4 + 2\text{H}_2\text{O}$	-135.6
$4 \text{ Formate} \rightarrow \text{CH}_4 + 3\text{CO}_2 + 2\text{H}_2\text{O}$	-130.1
$2 \text{ Ethanol} + \text{CO}_2 \rightarrow \text{CH}_4 + 2 \text{ acetate}$	-116.3
$\text{Acetate} \rightarrow \text{CH}_4 + \text{CO}_2$	-31.0

Source: Modified from Whitman et al. (2006).

living at moderate pH, temperature, and salinity, in contrast to many other archaea. They are significant for their production of large amounts of methane, which they produce under anaerobic conditions. Methanogens are very strict anaerobes, due in part to the sensitivity to oxygen of the enzymes involved in methanogenesis. Because of their lack of tolerance to oxygen, they're found in anoxic sediments, anaerobic digestors, and animal guts (see Section 8.5.1). In these environments, if sulfate is present, sulfate-reducing bacteria will outcompete the methanogens for hydrogen. Their metabolism has been well characterized, and we know that almost all methanogens can utilize hydrogen to reduce carbon dioxide, while some methanogens can utilize formate as the electron donor and fewer methanogens can use alcohols. A few other methanogens utilize C1 compounds containing methyl or acetate. The production of methane provides substantial energy for the organisms (see Table 2.4). Methanogens often live syntrophically with other bacteria, such as fatty-acid-oxidizing bacteria.

Methane, the product of methanogenesis, can be observed in swamps. Several microbial diversity classes at Woods Hole Marine Biological Laboratory have participated in a field trip to the local swamp, where they used wooden dowels to release methane from the swamp sediments. After capturing the methane in corked funnels, students carefully uncorked the funnels and lit the escaping methane to reproduce the experiment by Alessandro Volta (1745–1827) with marsh gas in the 1790s. Volta used his results

to create gas lanterns to provide light. Today, methane is a major greenhouse gas, and atmospheric isotopic studies estimate that approximately 74% of the methane produced is produced by microorganisms (Whitman et al. 2006).

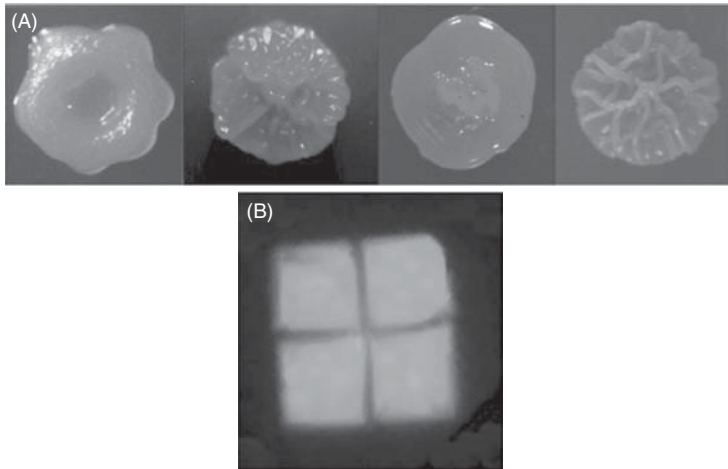
**Halophilic Archaea.** The order Halobacteriales, within the Euryarchaeota, encompasses the halophilic organisms found in hypersaline (salt concentrations >150–200 g/L) environments. If you’ve flown into San Francisco, CA, USA you have probably noticed the pinkish red-orange salt ponds (see Figure 2.11) on the edge of the bay. The color comes from the carotenoids in the cell membranes. Other habitats in which halophilic archaea are found include salt lakes, such as the Dead Sea, salt playas, salt formations, foods preserved in salty brines, and hides preserved with salt. How the halophiles tolerate such high salt conditions has been the focus of much study, which has revealed that they maintain high concentrations of ions such as potassium and chloride within their cells. The high intracellular ionic concentration has led to adaptations in their enzymes to allow them to function properly at these salt concentrations, which, in turn, has made them obligate dwellers in salty environments. Halophilic archaea require molar concentrations of sodium ions and the availability of magnesium and calcium in their environment.

One fascinating feature of many species within the Halobacteriales is the presence of retinal pigments, *bacteriorhodopsin*, which pumps protons out of the cell, and *halorhodopsin*, which pumps chloride ions into the cell (see Section 3.9.4). These pumps are fueled by solar energy. Halophilic archaea (Figure 2.12) can sometimes come in interesting shapes, such as the Walsby square “bacterium” (Walsby 1980), which maintain their buoyancy in water through gas-filled vacuoles.

**Archaeal Diversity in the Environment.** In general, bacteria in environmental studies are more diverse than archaea in the same environment, with some exceptions reviewed in Aller and Kemp (2008) (plankton, arsenite-oxidizing acidic thermal springs, subsurface hot springs, and methane-rich sediments of a hydrocarbon seep). Aller and Kemp



**Figure 2.11.** Satellite photo of salt ponds in 2002 on the edge of the San Francisco Bay. (Public-domain image from Wikimedia Commons, [http://upload.wikimedia.org/wikipedia/commons/b/b6/San Francisco Bay Salt ponds 2002.jpg](http://upload.wikimedia.org/wikipedia/commons/b/b6/San_Francisco_Bay_Salt_ponds_2002.jpg)). See insert for color representation.



**Figure 2.12.** (A) Colonies of haloarchaeal cells grown on nutrient agar with 20% NaCl for 2–3 months and originally isolated from alpine rock salt; the coloration comes from carotenoids and bacterioruberin [images courtesy of Helga Stan-Lotter; (B) *Haloquadratum walsbyi* or Walsby's square bacterium (although it is not a bacterium, but an archaeon). (Public-domain image from Wikimedia Commons, [http://en.wikipedia.org/wiki/File:Haloquadratum\\_walsbyi00.jpg](http://en.wikipedia.org/wiki/File:Haloquadratum_walsbyi00.jpg)).

(2008) speculate that this difference in diversity may be due to how archaea live in the environment, the energetic costs of their metabolism, and their metabolic flexibility, suggesting that many members of the Domain Bacteria are more flexible in less extreme environments. The degree to which archaeal and bacterial species are interlinked within an environment is not known and may shed light on the diversity of these two groups. In addition to possible differences in diversity, there are fundamental cellular and genomic differences, which help to elucidate archaeal evolution.

## 2.7 ARCHAEA–BACTERIA DIFFERENCES

You may have already noticed in the earlier sections that archaea and bacteria show major ecological differences and similarities. They also differ substantially at the cellular and genomic levels. The archaea have been shown to have a chimeric nature. Despite their bacteria-like morphology, they show great similarities to the eukarya in their transcription, translation, DNA repair, RNA polymerase, replication, and basal promoter sequences. A surprise finding was that members of the euryarchaeotal branch of the Archaea domain possess homologs of the eukaryotic histones. One of their fundamental differences from the bacteria is that their cell membranes contain isoprene sidechains that are ether-linked to glycerol. Archaeal cell walls are composed of glycoprotein, protein, and pseudomurein (but not murein), and their antibiotic sensitivity differs from bacterial antibiotic sensitivity. Some energy metabolism methods are unique to the archaea, such as methanogenesis. Overall, archaeal core housekeeping and metabolic functions are similar to bacterial ones, while their information-processing systems are more eukaryotic (Allers and Meverch 2005; Schleper et al. 2005).

## 2.8 EUKARYA: A CHANGING PICTURE OF PHYLOGENETIC DIVERSITY

The phylogeny of the eukarya has undergone and is undergoing many revisions based on new discoveries. Previously, several phyla of protists diverged at the base of the tree and several of these protists were believed to lack mitochondria (i.e., amitochondriate). This earlier phylogeny was based on 18S rDNA sequence analysis. New phylogenetic trees, based on other genes and proteins, suggest that these protists were not basal as originally thought, and the eukaryotic phylogeny is currently under revision (Parfrey et al. 2006). New findings now show that these groups, which include eukaryotes such as *Giardia* (a diplomonad), *Trichomonas* (a parabasilid), and *Encephalitozoon* (a microsporidian), have mitochondria-like proteins called *mitosomes*, hydrogenosomes, and mitochondrial gene remnants, respectively. Thus, these protists were actually not amitochondriate (Madigan et al. 2009). Microbial members of the eukarya include

- Protists
- Fungi
- Algae

These groups cover a stupefying amount of diversity, and we will highlight a few members of these groups.

## 2.9 PROTIST DIVERSITY

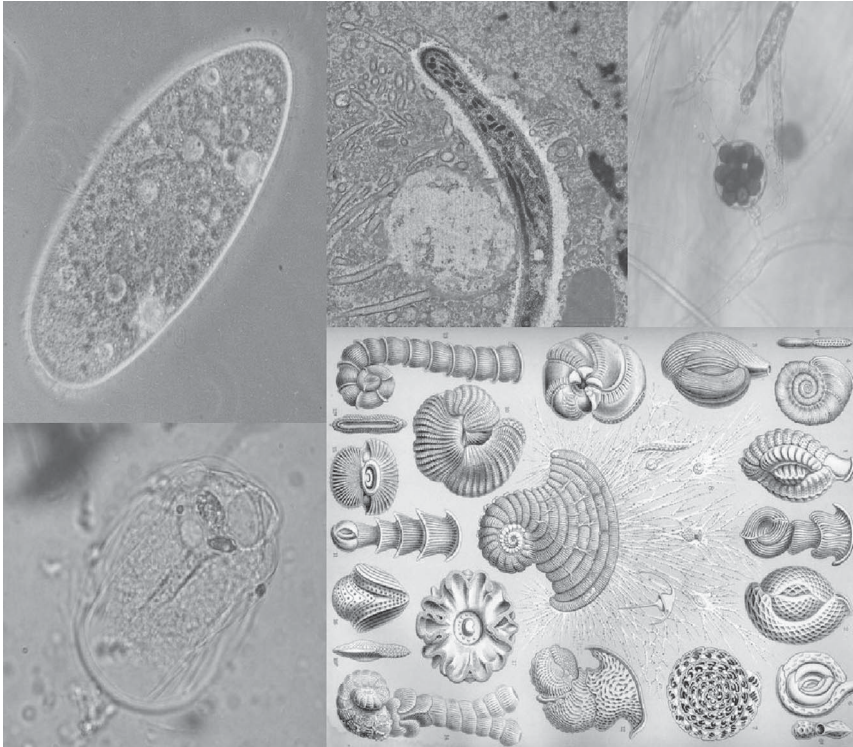
Protists represent a diverse group of unicellular eukaryotic organisms (Figure 2.13), or multicellular eukaryotes that lack specialized tissues. They are widespread, but most require liquid water. Formerly classed in the Protista (or Protoctista) kingdom, protists have now been dispersed within eukaryotic classification and the term *protist* is an informal group name. Protozoa, which most people think of as the animal-like protists, are heterotrophic, motile, single-celled organisms. Because eukaryotic classification is undergoing considerable revision and debate [see Parfrey et al. (2006) for a discussion of the proposed six eukaryotic “supergroups”], we will discuss important protist species, outside the context of their higher-level classification.

Beyond the estimated 100,000 described, extant species of protists (Cotterill et al. 2008), many novel species remain to be described, and our knowledge of their value is incomplete. We do know that protists play key ecosystem roles in biogeochemical cycling of nutrients and energy and that some, including the algae, which were historically included in the protists, produce oxygen. Their biotechnology potential is currently under investigation, with studies underway of the enzymes, pigments, and other compounds that protists produce. Probably most significant is the symbiotic role they play with many other organisms (see Section 8.5.1 for examples).

The protist group includes (Madigan et al. 2009) the following:

- Diplomonads (flagellated, unicellular organisms that contain two nuclei and mitosomes; e.g., *Giardia*)



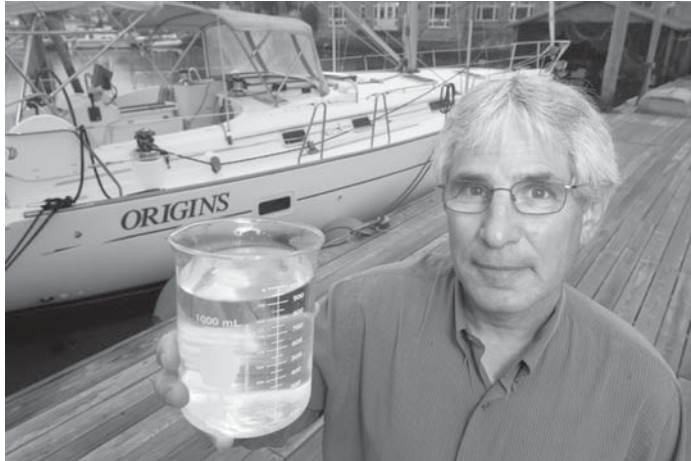


**Figure 2.13.** Image collage from Wikimedia Commons, [http://en.wikipedia.org/wiki/File:Protist\\_collage.jpg](http://en.wikipedia.org/wiki/File:Protist_collage.jpg).

- Parabasalids (organisms that contain a parabasal body and hydrogenosomes)
- Euglenozoans (flagellated, unicellular organisms that contain a flagellar crystalline rod)
- Alveolates (organisms that contain sacs in the cytoplasmic membrane, called *alveoli*), which include
  - Ciliates (possess cilia for motility during at least part of their life; e.g., *Paramecium*)
  - Dinoflagellates (named for their flagella that cause a spinning movement; marine and freshwater)
  - Apicomplexans (disease causing obligate animal parasites that contain degenerate chloroplasts called *apicoplasts*; e.g., *Plasmodium*, which causes malaria)
- Stramenopiles (oomycetes or water molds, diatoms, golden algae, brown algae)
- Cercozoans (previously called *amoeba*) and radiolarians (possess “thread-like pseudopodia”)
- Amoebozoa (use pseudopodia that are lobe-shaped; includes the slime molds)

## Microbial Spotlight

### MITCH SOGIN



Mitch Sogin holds up a liter of seawater that contains 10–100 times more species of bacteria than he expected to find, “and the species discovery curve is still going to the moon.”—(Photograph courtesy of Tom Kleindeinst and the Marine Biological Laboratory.)

Mitch Sogin has spent his life studying diversity, first in protists and now in Earth’s oceans. Reading *The Five Kingdoms: An Illustrated Guide to the Phyla of Life on Earth* by Lynn Margulis and Karlene Schwartz (1998) had a big impact on the direction that his research life took and led to his fascination with diversity. Coming from the lab of Carl Woese, where he studied the molecular evolution of diversity, he was able to attach the morphological diversity of protists to further studies of diversity. One of his biggest eureka moments came more recently from his studies of diversity in the oceans. “From the first dataset, it was an amazing experience.” The “census of marine microbes” project turned up several common species, but in addition, Sogin and colleagues found thousands of rare species whose role is still unknown in the marine ecosystem. To do this project, Sogin helped develop a new method of censusing, termed *454-tag sequencing*, which sequences a very small section of the hypervariable regions of rRNA genes. These amazing results have led to many more questions:

Why in the world is there so much diversity? There are a huge number of cells; [we] might estimate there are 10 to the 12th number of cells. Why are there no winners? Why do we have so many guys that are competing? Should we be looking at microbial ecology over geological time scales? Because we have this world of microbes, the way the system has evolved, if we go through bad times, and everything gets wiped out, maybe organisms survive by waiting, or exchanging DNA; maybe when you come out, you come out into a new environment. It is a microbial planet—that is what drives the system.



### 2.9.1 Protist Gallery

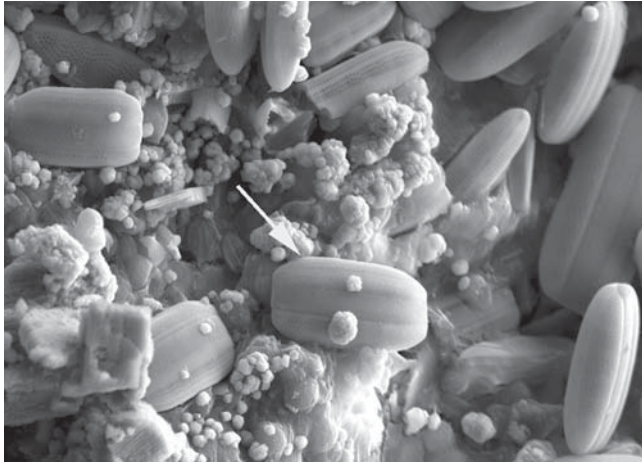
**Alveolates: Dinoflagellates.** Phylogenetically the dinoflagellates reside within the alveolates and are affiliated with the malarial parasite, *Plasmodium* and the parasite *Toxoplasma*. They are often photosynthetic, unicellular, and are motile as a result of the flagella that circle around the cell. Evolutionarily, they are fascinating organisms with highly compacted chromosomes that are maintained in this state by a liquid crystalline DNA state, many proteobacterial genes, and the loss of nucleosomes. Turbulence in the water will stimulate them to become bioluminescent as they are very sensitive to turbulence and multiply in calm water only. Dinoflagellates can be highly beneficial in their role as the zooxanthellae symbionts of corals, and very harmful as members of the algal blooms that cause “red tide,” producing the xanthophyll pigments that give the red coloration (Wong and Kwok 2005). As photosynthetic endosymbionts of the coral, they provide photosynthetically fixed carbon to the coral animals in return for a sheltered environment in which to live. One hypothesis concerning coral bleaching suggests that the loss of these zooxanthellae may contribute to the coral bleaching. Besides being abundant in marine habitats (free living or symbiotic), dinoflagellates also occur in freshwater, and in both environments they can be highly toxic. Their toxins lead to the death of large numbers of fish, and their accumulation in shellfish has caused cases of human poisoning.

**Stramenopiles: Diatoms.** Diatoms have captured the attention of biotechnology because of their ability to build nanocrystalline silica walls that are an inorganic–organic hybrid. The external silica structure, called a *frustule*, has polysaccharides and proteins added to it. These diatom frustules are resistant to decay after the organism dies and therefore form an important part of the geologic record as fossils, which suggests that diatoms are at least 200 million years old. Geneticists are also intrigued by how these organisms encode the means to build such intricate structures (Figure 2.14) that differ across tens of thousands of species of freshwater and marine diatoms. Investigation of the mechanisms for creating these intricate structures can guide and inspire human constructions of nano- and microcrystalline materials.

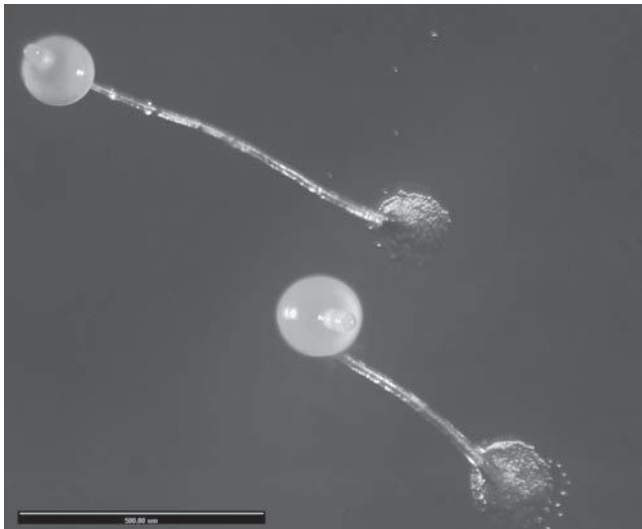
Why produce a silica wall instead of some other material? Predator protection is a driving force in the choice of silica, which is structurally very stable, and some researchers suggest that it is less costly to produce. Kröger and Poulsen (2008) review additional hypotheses, which include enhanced carbon dioxide acquisition due to the silica wall acting as a proton buffer, and the lattice of silica aiding in sunlight harvesting. Ecologically, diatoms are extremely important in marine habitats where they are key primary producers ( $\leq 40\%$  of ocean primary productivity). They also affect nutrient cycling because of their ability to sequester nutrients intracellularly, preventing competitors from acquiring these nutrients (Konhauser 2007).

Ecologically, diatoms are an important part of the microphytoplankton in the world's oceans because of their photosynthetic capabilities. Their widespread nature in marine and freshwater habitats makes them an ideal candidate for testing ecological theories concerning microbial distributions and whether microorganisms exhibit biogeographic patterns [see Soininen (2007) and further discussions in Section 4.7.3].

**Amoebozoa: The Slime Mold, Dictyostelium.** Labeled a “social amoeba,” *Dictyostelium* spp. (Figure 2.15) spend their life as either unicellular organisms or come together under starvation conditions as multicellular organisms, producing fruiting bodies similar to those produced by fungi. They are predators on bacteria, which they engulf



**Figure 2.14.** Diatoms (e.g., see white arrow) in the genus *Nitzschia*, from Soda Dam, a travertine structure, in New Mexico, exhibit some of the beauty of the frustules and the unicellular nature of most diatoms (photomicrograph courtesy of Michael Spilde).



**Figure 2.15.** *Dictyostelium discoideum* (image courtesy of Adam W. Rollins).

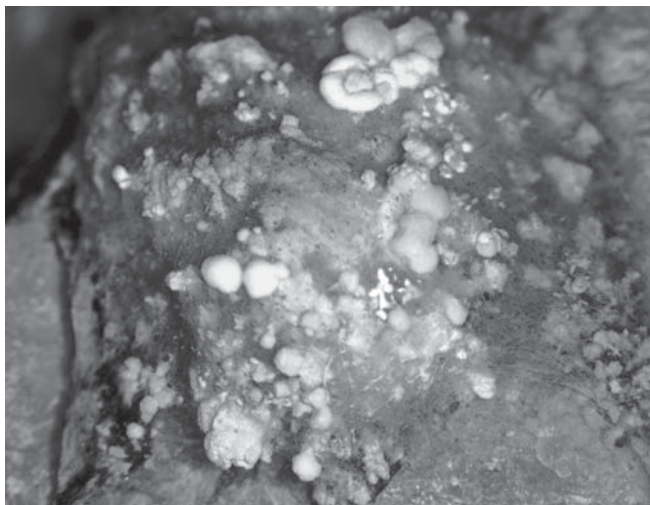
through phagocytosis, and are widely found in soils worldwide. The sequencing of their genome revealed many surprises, including a large genome of 12,500 genes, compressed into a genome of about 34 megabases (Mb), which is only about 1000 genes short of that of *Drosophila*'s 180-Mb genome (Insall 2005). Genome analyses also support the hypothesis that *Dictyostelium* is closely related to animals. Genes involved in cell signaling and motility, as would be expected in an organism that specializes in these functions, were found to be numerous. The survey of *Dictyostelium*'s genome has reinforced its use as a model organism for studying cell movement, especially actin-based motility, cell aggregation, and cell signaling.

## 2.10 FUNGAL DIVERSITY

Diversity abounds within the Fungi! The number of fungal species is estimated to be >1.5 million, of which approximately 75,000 have been described (Deacon 2006). What comes to mind when you think of the roles that fungi might play in the environment? Perhaps decomposition might be one of the first thoughts and indeed, this is one of their key roles (Figure 2.16). Fungi decompose and recycle organic matter, breaking down lignocellulose and other recalcitrant compounds. They are also pathogens and are responsible for large economic losses in crops due to their infestations. Notable infestations by fungi and fungus-like organisms have been implicated in the Irish famine, due to the potato blight, in Dutch elm diseases, and in chestnut blight. Quite recently, the Chytridiomycota were implicated in the decline of amphibians, in which they cause an often fatal disease called *chytridiomycosis*. As human pathogens, they have increased their prominence through the rise of fungal infections in immunocompromised patients, such as those with acquired immunodeficiency syndrome (AIDS), who often die as the direct result of opportunistic infections. They also have very positive roles in human life in food production (e.g., cheese) and drugs (e.g., penicillin) and in their associations with plants, discussed in Chapter 7.

Where the fungi fit into the tree of life has been one of the main questions concerning this tree of life. A pioneering study by Wainright et al. (1993) suggested that fungi are more closely related to animals than to plants and that the common ancestor of these two groups was probably a flagellated protist that resembles living choanoflagellates. The Chytridiomycota are considered to be the oldest of the fungi, and fossil evidence of fungi dates back at least 455 million years. What defines fungi as a group? Several important features delineate fungi (Deacon 2006), including:

- Their eukaryotic nature, including a membrane-bound nucleus and cytoplasmic organelles, sterol-containing membranes, 80S ribosomes, and cytoplasmic streaming.



**Figure 2.16.** Fungi degrading a bat that died on the wall of Carlsbad Cavern in New Mexico, USA.

- Heterotrophic metabolism: enzymes are secreted from hyphal tips to break down complex organic matter that is then absorbed from the environment through the cell wall and membrane.
- Growth as filaments, which increase in length at their tips (i.e., apical growth), as single-celled yeasts, or as both (i.e., dimorphic).
- Chitin- and glucan-containing cell walls.
- Haploid genome in many fungi.
- Asexual and sexual reproduction and the production of spores.

What are sometimes termed the “true” fungi, or the *Mycota*, contain five phyla:

- Basidiomycota
- Ascomycota
- Zygomycota
- Glomeromycota
- Chytridiomycota

Most people think of mushrooms (Figure 2.17) when they think of fungi. Mushrooms, toadstools, and some yeasts are grouped together in the phylum Basidiomycota, whose name derives from *basidium*, the spore-producing structure in which meiosis occurs, leading to the production of basidiospores. Several important pathogens reside within



**Figure 2.17.** Common basidiomycete found in the forests of the Jemez Mountains, New Mexico, USA (photo courtesy of Kenneth Ingham; copyright 2006).

this phylum, including rusts, such as *Puccinia*, and smut fungi. If you've ever grown corn, you may have encountered the smut that infects corn (Figure 2.18), creating a large gray mass on the corn that farmers disdain, but that is eaten as a delicacy in some parts of the world. Some members of this phyla produce deadly toxins, while others are cultivated by leaf-cutting ants.

Certainly the most numerous of all the fungi are those in the Ascomycota, which make up almost 75% of all described species (Deacon 2006). The defining characteristic of the Ascomycota is the presence of a sac-like structure termed an *ascus*, in which sexual spores, called *ascospores*, are produced. Most ascomycetes, however, are known only from their asexual stages. Many important pathogens reside within this group, including the organisms that causes athlete's foot, candidiasis (caused by *Candida albicans*), and aspergillosis (caused by *Aspergillus fumigatus*) and others that cause diseases in crops, such as *Claviceps purpurea*, a pathogen on cereal crops. Ascomycetes also have many positive roles, including mycorrhizal associations with trees and symbiotic interactions in lichens (see Section 6.4.2). They are also cultivated by beetles (see Section 8.5.3). Perhaps



**Figure 2.18.** Smut fungi growing on corn. (Public domain image from <http://en.wikipedia.org/wiki/File:Huitlacoche.jpg>; originally from [http://flickr.com/photos/stuart\\_spivack3/5645614/](http://flickr.com/photos/stuart_spivack3/5645614/)).

one of the most appreciated members of the Ascomycota is *Saccharomyces cerevisiae*, which is also known as “brewer’s” or “baker’s yeast” because of its role in beer, wine, and bread fermentation. Its genome was the first eukaryotic genome sequenced and it has been used for decades as a model organism.

The production of zygospores, thick-walled resting spores that are produced in sexual reproduction, and the lack of crosswalls in their hyphae, are two hallmarks of the Zygomycota. These common soil fungi, which grow saprophytically, include genera such as *Mucor* and *Rhizopus*. Some members of this phylum cause human diseases termed *zygomycoses*.

A relatively new phylum, the Glomeromycota, contains the arbuscular mycorrhizal fungi. These fungi were originally included in the Zygomycota, but phylogenetic evidence has confirmed that arbuscular mycorrhizas represent a separate phylum. These fungi are found associated with most plant roots (some estimate 80% of vascular plants) and play vital roles in plant nutrition by providing soil mineral nutrients to the plant, which in turn provides sugars to the fungi (see Section 7.5.2).

The fifth phylum, the Chytridiomycota or chytrids, are found in both moist soils and aquatic environments. This ancient fungal lineage is set apart from other fungi by the production of flagellated, motile zoospores in most species. These organisms are usually small and either single cells or branched chains of cells, which are not easily discernible in the environment. Deacon (2006) finds them intriguing and notes: “Anybody who has watched a chytrid zoospore crawling like an amoeba along the body of a nematode, searching for the best site to encyst, then winding in its flagellum encysting and penetrating the host will never forget the experience.”

Chytrids, such as *Batrachochytrium dendrobatidis*, have been suggested to be the cause of the rapid decline of many amphibians (Rodder et al. 2008), but much remains to be learned about this phenomenon.

The fungi are important players in the microbial world, as they are major pathogens of plants and animals, absolutely essential partners in symbiotic relationships such as mycorrhizas and lichens, and decomposers and recyclers extraordinaire.

## 2.11 ALGAL DIVERSITY

You may encounter algae in the grocery store as a food supplement (e.g., seaweed or the single-celled green alga, *Chlorella*), as one of the possible partners in lichens (see Figure 2.19), as a pollutant in eutrophic lakes or rivers (see Figure 2.20), as part of the biofilm on rocks in streams that makes the rocks slippery, and in the outflow of hot springs, where the water is cooler. Algae perform oxygenic photosynthesis, contain chlorophyll, and are eukaryotes. It is estimated that 50% of the oxygen produced in the world today is produced by oxygenic phytoplankton, of which the algae are a major part. One scientist estimates that the oxygen in one out of every five breaths that a human draws is from one particular alga, *Prochlorococcus*, which is very abundant in the oceans.

Two major groups are included within the algae: the red algae (Rhodophyta) and the green algae (Chlorophyta). The green algae are most often found in freshwater habitats, but are occasionally found in soil that is moist, in marine habitats, or as part of some lichens. An unusual habitat for some green algae is snow, where they appear to give the snow a pink tinge. They can be unicellular or multicellular, contain chloroplasts that have chlorophylls *a* and *b*, and some are filamentous or colonial. One particularly intriguing





**Figure 2.19.** Some lichens, such as this *Cryptothecia rubrocincta* or Christmas lichen from Florida, contain an algal partner. See insert for color representation.



**Figure 2.20.** *Lyngbya* algal bloom on the Rio Grande River, New Mexico, USA (image courtesy of New Mexico Environment Department).

alga is *Ostreococcus tauri*, which at the time of the publication of its genome in 2006 was the smallest eukaryotic genome known. *Ostreococcus tauri* is considered one of the smallest eukaryotes (picoeukaryotes) known, with its size of approximately 1  $\mu\text{m}$ . Along with its small cell size comes a small, highly compacted genome of 12.56 million base pairs (Mbp) distributed across 20 chromosomes. This genome holds many surprises, including genes for  $C_4$  photosynthesis, usually found only in plants, the highest level of heterogeneity within a eukaryotic genome and an extensive intergenic region reduction, making it a model genome for the study of genome evolution in eukaryotes (Derelle et al. 2006). The bulk of red algae are marine, but some are found in freshwater and terrestrial habitats. In contrast to green algae, the red algae lack chlorophyll *b*, but do contain chlorophyll *a* and phycobiliproteins (which green algae lack). Their red color comes from phycoerythrin, and most are multicellular. Microbiologists appreciate them as the source of agar.

## 2.12 VIRAL DIVERSITY

Viruses (Figure 2.21) can be defined as obligate, intracellular parasites that utilize the host cell machinery to manufacture proteins in order to replicate. Thus, they do not fit the classic definition of life, but are usually included as one of the categories of microorganisms. They are usually classified according to their nucleic acid content, which can be double- or single-stranded DNA or RNA, but not both, and by morphotype. Their genomes vary tremendously in size from 2 to 335 kilobases (kb) (Haenni and Mayo 2006). Viruses can be *lytic*, resulting in lysis of the host cell; *lysogenic*, where the viral genome is incorporated into the host genome, creating a prophage; or *pseudolysogenic*, a less active lytic state in which a nutrient-limited host cell still grows and divides. Those that



**Figure 2.21.** Gblytic agent tailed virus (image courtesy of Dale Griffin).



infect bacteria are called *bacteriophages* or *phages*. Medical science has studied viruses as disease agents for many years and now uses viruses as therapeutic agents. Their roles in lateral gene transfer and as genetic reservoirs are important. Viruses have now been shown to have major impacts on the ecology of other organisms and by consequence, on biogeochemical cycling, roles that were previously unrecognized.

Although soil viruses are abundant in soils and known to infect both beneficial and pathogenic soil microorganisms, their ecology is still poorly understood (Kimura et al. 2008). The greater number of fungi in soils than in the oceans, suggests that fungal viruses may play important roles in soils. The heterogeneity of the soil habitat suggests that many important discoveries will come from the study of soil viral ecology, as we have seen from the study of the oceans' viruses. We now recognize that viruses are abundant (ranging from  $10^6$  to  $10^8$  mL<sup>-1</sup> in the ocean and  $10^8$  to  $10^9$  cm<sup>-3</sup> of sediment) and that they play critical roles in the world's oceans (Suttle 2005). Some of the families of viruses found in the ocean include the *myoviruses*, which possess contractile tails and are usually lytic; the *podoviruses*, which have noncontractile tails (short) and are usually lytic, and the *siphoviruses*, which are lysogenic with non-contractile tails (long). These three viral families differ in the breadth of their host ranges and therefore exhibit different ecological strategies; those that have broad host ranges are *r*-selected (high reproduction rate, short generation time), and those with narrow host ranges are *K*-selected (low reproduction rate, long generation time).

Viral diversity is even more staggering and unknown than bacterial diversity. Suttle (2005) reviews metagenomic studies that reveal that 200 L of ocean water contain several thousand viral genotypes and that a kilogram of sediment has a million viral genotypes, many of which are unknown. Although we may not know the identities of all the players, we do know that mortality caused by viruses leads to the release of many nutrients from dead organisms, converting biomass to dissolved organic carbon and other nutrients. Viruses may infect the most prevalent species, leading to changes in species diversity and the structure of communities. As viruses infect different hosts, they also play an important role in lateral gene transfer. Although there is much to learn about viral ecology, we are gaining a critical view of their importance in many ecosystems.

## 2.13 SUMMARY

The diversity of algal, protist, fungal, bacterial, and archaeal microorganisms on Earth is truly staggering, and we are discovering new diversity within many of these groups at a rapid rate, due to the development of molecular phylogenetic and genomic techniques. For example, the number of bacterial phyla has grown from 11 in 1987 to 52 in 2003, with possibly many more currently being identified. These findings have caused the tree of life to grow to the point where most of the diversity is microbial in nature. Efforts to classify microorganisms do not rely on morphology as many bacterial and archaeal species have common shapes, such as rod, filament, and coccoid morphologies. Classification of this diversity has moved from phenotypic (metabolic characteristics in particular) to DNA-DNA hybridization and similar G-C ratios, to phylogenetic trees on the basis of the 16S ribosomal small subunit. However, molecular phylogeny and genome sequencing efforts have revealed the inadequacy of our concept of what a species is in the microbial world. Understanding what controls this amazing diversity from an ecological perspective is receiving increasing attention as microbial ecologists apply ecological concepts to microbial diversity, which, in turn, is modifying our understanding of ecology.

## 2.14 DELVING DEEPER: CRITICAL THINKING QUESTIONS

1. Can you think of any habitats on Earth where microorganisms have not been found?
2. How does the system of three domains differ from that of the previous concept of five kingdoms?
3. After reading Norm Pace's 2006 *Nature* paper on usage of the term *prokaryote*, will you continue to use the word or not? Why or why not?
4. How was the Archaea domain determined to be a separate domain?
5. How many phyla are there within the Archaea? What are the arguments for additional phyla?
6. How is a new phylum within the Bacteria identified?
7. What is the state of eukaryotic classification?
8. What characteristics identify members of the Fungi? Where do the fungi fit in the tree of life? What key ecological role do fungi perform?
9. What groups make up the protists? Is Protista a valid classification?
10. What are some of the important ecological roles that the protists perform?
11. How would you define viruses? What key ecological role do they play in ecosystems?
12. If we classify plants and animals according to their appearance, why is bacterial/archaeal morphology not useful for classification?
13. What methods are currently used to classify microorganisms?

## BIBLIOGRAPHIC MATERIAL

### Further Reading

- Cohan FM, Perry EB (2007), A systematics for discovering the fundamental units of bacterial diversity, *Curr. Biol.* **17**:R373–R386.
- D'Amico S, Collins T, Marx J-C, Feller G, Gerday C (2006), Psychrophilic microorganisms: Challenges for life, *EMBO Reports* **7**:385–389.
- Deacon J (2006), *Fungal Biology*, 4th ed., Malden, MA: Blackwell Publishing.
- Fraser C, Alm EJ, Polz MF, Spratt BG, Hanage WP (2009), The bacterial species challenge: Making sense of genetic and ecological diversity, *Science* **323**:741–746.
- Hugenholtz P (2002), Exploring prokaryotic diversity in the genomic era, *Genome Biol.* **3**:reviews 0003.1–0003.8.
- Woese CR (1987), Bacterial evolution, *Microbiol. Rev.* **51**:221–271.

### Cited References

- Aller JY, Kemp PF (2008), Are Archaea inherently less diverse than Bacteria in the same environments? *FEMS Microbiol. Ecol.* **65**:74–87.
- Allers T, Mevarech M (2005), Archaeal genetics—the third way, *Nature Rev. Genetics* **6**:58–73.
- Angert ER (2005), Alternatives to binary fission in bacteria, *Nature Rev. Microbiol.* **3**:214–224.

- Beatty JT, Overmann, J, Lince MT, Manske AK, Lang AS, Blankenship RE, Van Dover CL, Martinson TA, Plumley FG, Buchanan BB (2005), Bacterial anaerobe from a deep-sea hydrothermal vent, *Proc. Natl. Acad. Sci. (USA)* **102**:9306–9310.
- Brochier-Armanet C, Boussau B, Gribaldo S, Forterre P (2008), Mesophilic crenarchaeota: Proposal for a third archaeal phylum, the Thaumarchaeota, *Nature Rev. Microbiol.* **6**:245–252.
- Bryant DA, Frigaard N-U (2006), Prokaryotic photosynthesis and phototrophy illuminated, *Trends Microbiol.* **14**:488–496.
- Cotterill FPD, Al-Rasheid K, Foissner W (2008), Conservation of protists: is it needed? *Biodivers. Conserv.* **17**:427–443.
- Deacon J (2006), *Fungal Biology*, 4th ed., Malden, MA: Blackwell Publishing.
- Derelle E, Ferraz C, Rombauts S, Rouzé P, Worden AZ, Robbens S, Partensky F, Degroeve S, Echeynié S, Cooke R, et al. (2006), Genome analysis of the smallest free-living eukaryote *Ostreococcus tauri* unveils many unique features, *Proc. Natl. Acad. Sci. (USA)* **103**:11647–11652.
- Emerson D, Rentz JA, Liburn TG, Davis RE, Aldrich H, Chan C, Moyer CL (2007), A novel lineage of Proteobacteria involved in formation of marine Fe-oxidizing microbial mat communities, *PLoS ONE* **2**:e667.
- Ferrera I, Longhorn S, Banta AB, Liu Y, Preston D, Reysenbach A-L (2007), Diversity of 16S rRNA gene, ITS region and *acIB* gene of the *Aquificales*, *Extremophiles* **11**:57–64.
- Fraser C, Alm EJ, Polz MF, Spratt BG, Hanage WP (2009), The bacterial species challenge: Making sense of genetic and ecological diversity, *Science* **323**:741–746.
- Golyshina OV, Timmis KN (2005), *Ferroplasma* and relatives, recently discovered cell wall-lacking archaea making a living in extremely acid, heavy metal-rich environments, *Environ. Microbiol.* **7**:1277–1288.
- González JE, Marketon MM (2003), Quorum sensing in nitrogen-fixing rhizobia, *Microbiol. Molec. Biol. Rev.* **67**:574–592.
- Haenni A-L, Mayo M (2006), Virus systematics: taxonomy for the tiny, *Microbiol. Today* (Nov.): 156–159.
- Huber H, Hohn MJ, Rachel R, Fuchs T, Wimmer VC, Stetter KO (2002), A new phylum of Archaea represented by a nanosized hyperthermophilic symbiont, *Nature* **417**:63–67.
- Hugenholtz P. 2002. Exploring prokaryotic diversity in the genomic era. *Genome Biology* **3**:reviews 0003.1–0003.8.
- Hugenholtz P, Goebel BM, Pace NR (1998), Impact of culture-independent studies on the emerging phylogenetic view of bacterial diversity, *J. Bacteriol.* **180**:4765–4774.
- Insall R (2005), The *Dictyostelium* genome: The private life of a social model revealed? *Genome Biol.* **6**:article 222.
- Kimura M, Jia Z-J, Nakayama N, Asakawa S (2008), Ecology of viruses in soils: Past, present and future, *Soil Sci. Plant Nutr.* **54**:1–32.
- Kneip C, Lockhart P, Vo ß C, Maier U-G (2007), *BMC Evolut. Biol.* **7**:55.
- Konhauser K (2007), *Introduction to Geomicrobiology*, Malden, MA: Blackwell Publishing.
- Kröger N, Poulsen N (2008), Diatoms—from cell wall biogenesis to nanotechnology, *Annu. Rev. Genetics* **42**:83–107.
- Madigan MT, Mrtinko JM, Dunlap PV, Clark DP (2009), *Brock Biology of Microorganisms*, 12th ed., San Francisco: Pearson Benjamin Cummings.
- Margulis L, Schwartz KV (1998), *Five Kingdoms: An Illustrated Guide to the Phyla of Life on Earth*, 3rd ed., New York: Freeman.
- Martin W, Koonin EV (2006), A positive definition of prokaryotes, *Nature* **442**:868.
- Mendell JE, Clements KD, Choat JH, Angert ER (2008), Extreme polyploidy in a large bacterium, *Proc. Natl. Acad. Sci. (USA)* **105**:6730–6734.

- Oren A (2006), The order Halobacteriales, in Dworkin M, Falkow S, eds., *The Prokaryotes: A Handbook on the Biology of Bacteria*, New York: Springer, pp. 113–164.
- Pace NR (2006), Time for a change, *Nature* **441**:289.
- Parfrey LW, Barbero E, Lasser E, Dunthorn M, Bhattacharya D, Patterson DJ, Katz LA (2006), Evaluating support for the current classification of eukaryotic diversity, *PLoS Genetics* **2**:2062–2072.
- Rappé MS, Giovannoni SJ (2003), The uncultured microbial majority, *Annu. Rev. Microbiol.* **57**:369–394.
- Robertson CE, Harris JK, Spear JR, Pace NR (2005), Phylogenetic diversity and ecology of environmental Archaea, *Curr. Opin. Microbiol.* **8**:638–642.
- Rodder D, Veith M, Lotters S (2008), Environmental gradients explaining prevalence and intensity of infection with the amphibian chytrid fungus: The host's perspective, *Animal Conserv.* **11**:513–517.
- Sawada H, Kuykendall LD, Young JM (2003), Changing concepts in the systematics of bacterial nitrogen-fixing legume symbionts, *J. General Appl. Microbiol.* **49**:155–179.
- Schleper C, Jurgens G, Jonuscheit M (2005), Genomic studies of uncultivated Archaea, *Nature Rev. Microbiol.* **3**:479–488.
- Soininen J (2007), Environmental and spatial control of freshwater diatoms—a review, *Diatom Res.* **22**:473–490.
- Stetter KO (2006), Hyperthermophiles in the history of life, *Philos. Trans. Royal Society B* **361**:1837–1843.
- Suttle CA (2005), Viruses in the sea, *Nature* **437**:356–361.
- Wainright PO, Hinkle G, Sogin ML, Stickel SK (1993), Monophyletic origins of the Metazoa: An evolutionary link with fungi, *Science* **260**:340–342.
- Walsby AE (1980), A square bacterium, *Nature* **283**:69–71.
- Whitman WB, Bowen TL, Boone DR (2006), The methanogenic bacteria, in Dworkin M, Falkow S, eds., *The Prokaryotes: A Handbook on the Biology of Bacteria*, New York: Springer, pp. 165–207.
- Woese CR (1987), Bacterial evolution, *Microbiol. Rev.* **51**:221–271.
- Woese CR, Fox GE (1977), Phylogenetic structure of the prokaryotic domain: The primary kingdoms, *Proc. Natl. Acad. Sci. (USA)* **74**:5088–5909.
- Woese CR, Kandler O, Wheelis ML (1990), Towards a natural system of organisms—proposal for the domains Archaea, Bacteria, and Eucarya *Proc. Natl Acad Sci. USA.* **87**:4576–4579.
- Wong JTY, Kwok ACM (2005), Proliferation of dinoflagellates: Blooming or bleaching, *Bioessays* **27**:730–740.
- Young KD (2007), Bacterial morphology: Why have different shapes? *Curr. Opin. Microbiol.* **10**:596–600.

### Internet Sources

- <http://www.microbeworld.org/microbes/>.
- [http://tolweb.org/notes/?note\\_id=52](http://tolweb.org/notes/?note_id=52).
- <http://www.doctorfungus.org/>.
- <http://www.tolweb.org/Fungi>.
- <http://serc.carleton.edu/microbelife/extreme/index.html>.
- [http://atol.sdsc.edu/AToL: Assembling the Tree of Life](http://atol.sdsc.edu/AToL:Assembling%20the%20Tree%20of%20Life).
- [http://www.genomesonline.org/GOLD: Genomes OnLine Database](http://www.genomesonline.org/GOLD:Genomes%20OnLine%20Database).

# COMPLEXITY AND SIMPLICITY OF CELL SYSTEMS

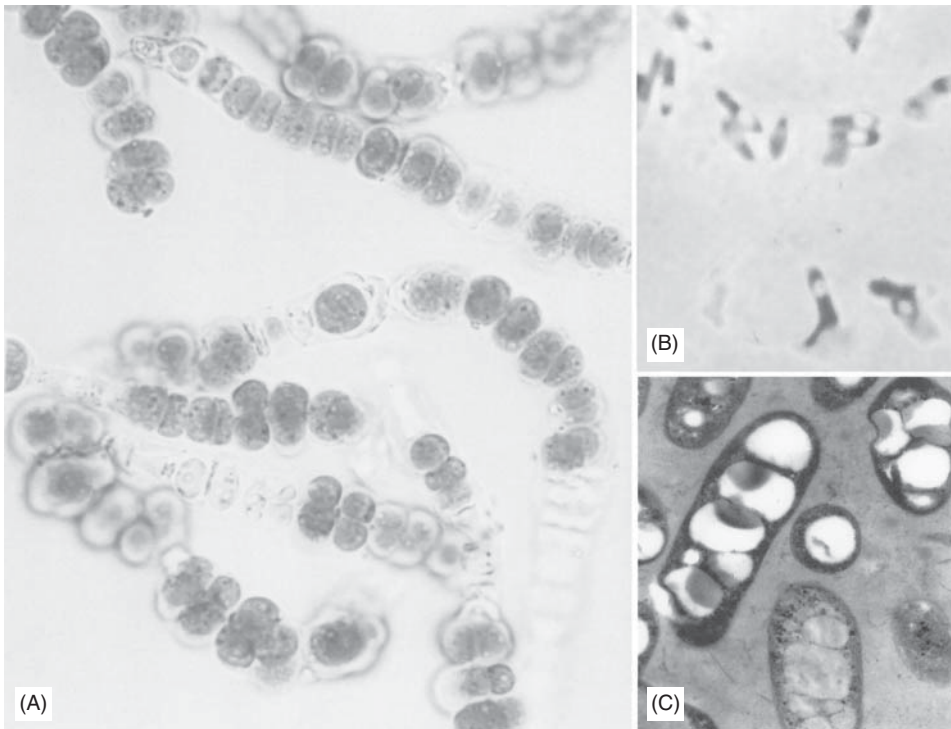
## 3.1 CENTRAL THEMES

- Not all microorganisms are the same size and shape. In some cases the specific size or shape of the microorganism provides an advantage to the microorganism.
- Movement enables microorganisms to grow in appropriate environments, and in aquatic environments, cells use chemotaxis to respond to specific environmental stimuli.
- In some instances it is desirable for bacteria to be immobile in the environment. Attachment is an important process because bacteria have developed several different mechanisms for attachment.
- Persistence of microorganisms may result from slow continuous growth or could be due to production of spores and other resistive cells.
- In a few instances, microorganisms have developed lifecycles that optimize microbial growth for specific environments.
- Microorganisms occur as biofilms or as microcolonies in the environment and not just dispersed individual cells.
- The environment selects organisms that have developed specific cellular or metabolic processes for growth in that environment.

- Sensory systems are used by microorganisms to respond to changes in the environment with cellular changes that enable organisms to grow in a specific environment.
- Microbial growth is dependent on electron flow through a series of redox reactions, and microorganisms have evolved to obtain energy from various inorganic electron donors or electron acceptors.

### 3.2 INTRODUCTION

While all microbial cells met the requirement for life (e.g., growth, reproduction, response to environmental changes), there is considerable range in cellular characteristics of the various species. When considering the bacterial cell as an individual life form, there may be as much variability between bacteria as there is throughout the plant and animal kingdoms. Some examples of differences in prokaryotic cells are seen in Figure 3.1. In many instances this variation of bacteria at the individual or cell level reflects adaptations to specific chemical or physical environments. Rarely are the physical and chemical parameters constant in nature, with nutrition ranging from “feast to famine” and environmental

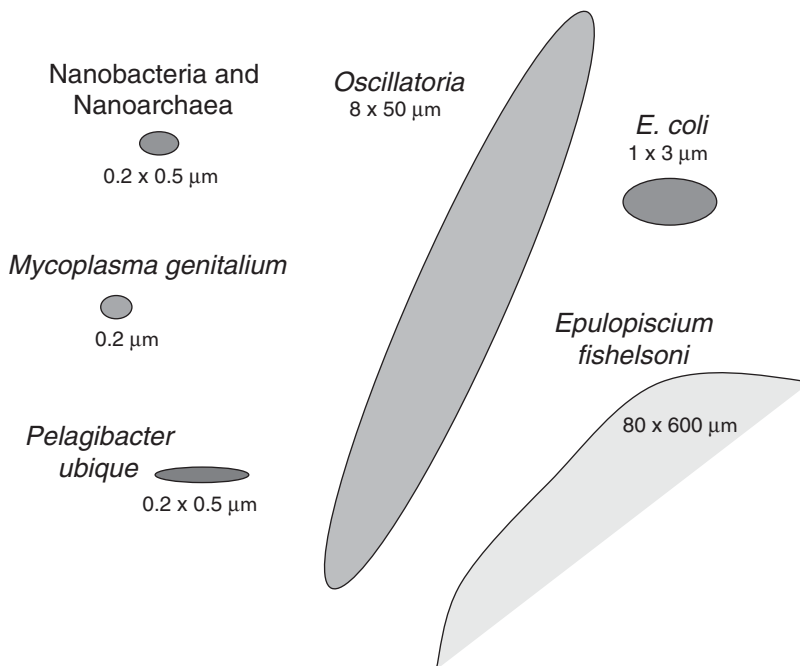


**Figure 3.1.** Examples of different prokaryote cell types: (A) *Fischerella*, a cyanobacterium (photograph provided by Sue Barns); (B) micrograph of *Bacillus* seen by light microscopy showing highly refractile endospores (arrow) (photograph provided by Larry Barton); (C) thin section of *Azospirillum brasilense* with large granules containing polymers of  $\beta$ -hydroxybutyric acid (photograph provided by Larry Barton).

parameters ranging from moderate to extreme. In a few bacteria this change may be observed in cell size and shape where a specific cellular characteristic may be uniquely appropriate for a specific environment. Many bacteria have similar cellular morphology but differ in that they have specific biochemical characteristics that reflect physiological adaptations. This chapter addresses some of the cellular characteristics of microorganisms that make them suitable for the environments that they inhabit.

### 3.3 CELL PARAMETERS

Across the spectrum of species in the world of plants and animals, there is considerable variation in the size and shape of an individual. For some time, it was considered that bacteria of different species had cells of similar morphology. It is now apparent that there is considerable variation in size of bacterial cells (see Figure 3.2) and the smaller cells do not include the resting cells or spores. Using the cell of *Escherichia coli* for comparison, individual cells of some bacterial species are much smaller, and cells of other species are much larger. This range in cell size of bacteria required scientists to evaluate the minimum size of a cell to accommodate genomic DNA and examine the maximum size of a cell that lacks internal organelles. Size can be an advantage for bacteria, with minute cells capable of growing in cracks or crevices, including deep subterranean environments where nutrients are present and the cells are able to escape predators in the surrounding. If the microorganism is very large in size, it is a deterrent for phagocytic predators, and large microorganisms have an advantage in nutrient storage. Rod- or spiral-shaped



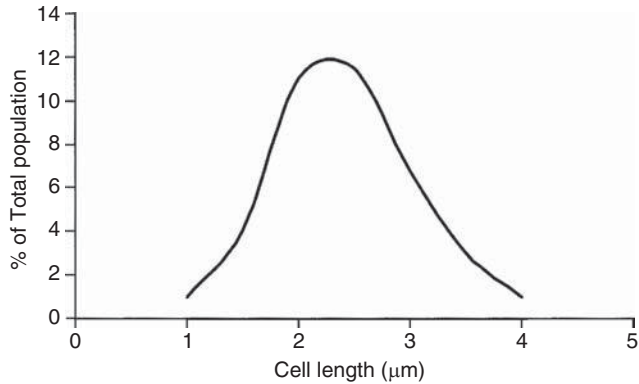
**Figure 3.2.** Relative size of some bacteria.



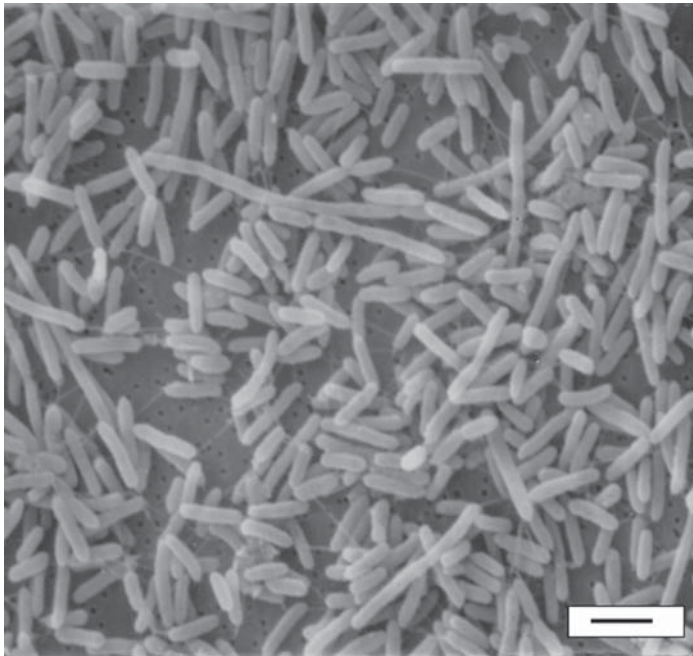
cells enable cells to increase volume, while the cell diameter may be about that of a coccus cell. Expanded surface-to-volume ratio is observed in flat or disk-shaped cells of *Pyrodictium abyssi*, a hyperthermophilic Crenarchaeota.

### 3.3.1 Life at the Lowest Level

Examination of cells of a bacterial population reveals that the diameter of the cell is relatively constant but cell length varies. As shown in Figures 3.3 and 3.4, the length of



**Figure 3.3.** Size distribution of *E. coli* growing in a broth.



**Figure 3.4.** Electron micrograph of a rapidly growing culture of *Pseudomonas* sp. showing a range of cell sizes (electron micrograph provided by Larry Barton).



an individual cell of *E. coli* can range from approximately 1 to 4  $\mu\text{m}$ , with an average length of 2.4  $\mu\text{m}$ . A range in cell length is observed in all bacterial cultures and reflects the difference in size attributed to cell division processes. A few bacterial species have cells with an average length of 0.1–0.5  $\mu\text{m}$  and are referred to as *nanobacteria*. As summarized in the following list, there is a broad distribution of these nanoprokaryotes in our environment and only recently scientists have focused on them:

- ***Host-dependent symbionts***

*Baumannia cicadellincola*—a dual symbiont in sharpshooters has genes for synthesis of vitamins and cofactors but lacks genes for synthesis of amino acids (Wu et al. 2006).

*Buchnera aphidicola*—a symbiont of insects lacking many genes that cannot grow outside the host (Pérez-Brocal et al. 2006)

*Carsonella ruddii*—a symbiont of insects (Nakabachi et al., 2006; Thaoet et al. 2000)

*Sulcia muelleri*—one of the dual symbionts in sharpshooters deficient in genes for amino acid synthesis (Wu et al. 2006)

- ***Nanobacteria***

*Mycoplasma genitalium*—bacteria that lack a cell wall and are obligate pathogens of humans (Wainwright 1999)

*Nanoarchaeum equitans*—an obligate parasite on *Ignicoccus*, another member of the Archaea (Huber et al. 2000)

*Pelagibacter ubique*—present in all oceans, where they account for 25% of all the bacteria present (Rappé et al. 2002)

*Herminiimonas glaciei*—Gram-negative bacterium isolated from a 120,000-year-old Greenland glacier ice core (Loveland-Curtze et al. 2009)

- ***Ultramicroscopic bacteria (UMB)***

*Actinobacteria*—isolated from freshwater (Hahn et al. 2003)

*Arthrobacter* and *Propionibacterium*—soil bacteria related to these genera (Panikov 2005)

*Spirillum*, *Leucothrix*, *Flavobacterium*, *Cytophaga*, and *Vibrio* spp.—representatives of the autochthonous bacterial communities from marine and estuarine environments (Roszak and Colwell 1987)

*Sphingopyxis alaskensis*—a marine bacterium of the class Alphaproteobacteria (Godoy et al. 2003)

Unclassified bacteria—isolated from rice paddy soil; belong to the Verrucomicrobiales lineage (Janssen et al. 1997)

Uncharacterized isolates—isolated from soil environments (Bakken and Olsen 1987)

Nanoprokaryotes have been reported to be present in various geologic formations, including Martian meteorite fragments ALH84001 and Allan Hills 84001 (Folk and Taylor 2002). A marine organism isolated from the hydrothermal system near Iceland is

*Nanoarchaeum equitans* (Figure 2.9), which lacks genes for independent growth, thereby making it an obligate parasite of *Ignicoccus* another archaea (Huber et al. 2000). Of considerable significance is the nanobacterium *Pelagibacter ubique* because it has been reported to be the most abundant microorganism in marine environments (Rappé et al. 2002).

Scientists are looking for nanoorganisms in various environments, and more recent reports have revealed the presence of several archaeal species in acid mine waters (Baker et al. 2006). Considerable controversy surrounds the report that nanobacteria contribute to human diseases where the etiology is not established (Martel et al. 2008). While certain bacterial and archaeal isolates are appropriately called *nanoprokaryotes*, small structures between 20 and 50  $\mu\text{m}$  in size reported to be pathogenic nanobacteria may be too small to contain a cell wall, plasma membrane, genomic DNA, and ribosomes (Koch, 1996; Urbano and Urbano 2007). In order to obtain definitive evidence that small structures are, indeed, nanobacteria, reports should include analysis of extracted DNA and physiological activities of the cultured nanocells.

Unlike the nanoprokaryotes, UMBs are found in nutrient-limiting environments, and the cells shrink as bacteria digest themselves to maintain cell viability. When nutrients in the environment are restored, the UMB cell enlarges to its original size and growth is initiated. Many bacterial species are capable of becoming UMBs, and a fraction of the population remains viable for extended periods of time when nutrients are limited. In freshwater oligotrophic environments predominated by Gram-negative bacteria, UMBs account for 4–7% of the total population, while soil containing mostly Gram-positive organisms has 30% of the soil bacteria as UMBs (Panikov 2005; Morita 1997). UMBs have been considered useful in bioremediation of soil contaminated with organic wastes because the small size of the UMB would enable them to move through the porous soil matrix.

Of biological interest is the minimal size that the materials necessary for life can be packaged. One of the basic requirements for life is the presence of genomic DNA, and while DNA is not condensed into chromosomes in bacteria, there is considerable coiling of the linear DNA macromolecule in bacterial cells. Bacteria and their DNA content are listed in Table 3.1. From molecular biology studies, it is seen that the quantity of genomic DNA varies with the species, and in general bacteria with considerable levels of DNA have a broad number of genes, enabling bacteria to grow in many different environments. Host-dependent bacteria may have lost genes that would enable the bacteria to grow outside the host. An interesting example of dual nanobacterial symbiosis occurs with the glassy wing sharpshooter, *Homalodisca coagulata*, where one nanobacterium is *Baumannia cicadellinicola* with 0.68 Mbp (million base pairs) of DNA and the second nanobacterium is *Sulcia muelleri* with only 0.15 Mbp of DNA (Wu et al. 2006).

### 3.3.2 Large Microorganisms

Scientists have considered that there is a size limit for prokaryotic cells because of the requirement for nutrients to diffuse through the cytoplasm. The surface-to-volume ratio is important for cells because the uptake of nutrients is dependent on diffusion outside the cell, within the cytoplasm, and acquisition of single molecules across the plasma membrane. Cells with a high surface-to-volume ratio would more rapidly distribute chemicals within the cell than cells with a lower surface-to-volume ratio. This surface-to-volume ratio is described in Box 3.1. Some relatively large bacterial cells have been identified,

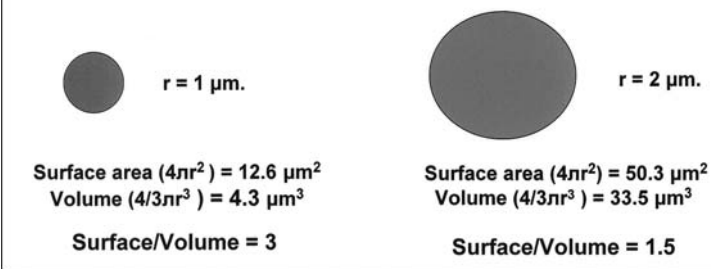
TABLE 3.1. Genome Content and Cell Size of Selected Microorganism

Species	DNA Size (Mbp <sup>a</sup> )	Cell Size (μm)
<i>Thiomargarita namibiensis</i>	?	100–200
<i>Epulopiscium fishelsoni</i>	?	80 × 600
<i>Beggiatoa</i> spp.	7.4	50 × 160
<i>Myxococcus xanthus</i>	9.4	0.75 × 5
<i>Escherichia coli</i>	4.60	1 × 3
<i>Bacillus subtilis</i>	4.20	0.7–0.8 × 2–3
<i>Haemophilus influenzae</i>	1.83	0.3–0.5 × 0.5–3
<i>Methanobacterium</i>	1.75	0.5–1.0
<i>Pyrococcus horikoshii</i>	1.74	0.2
<i>Pelagibacter ubique</i>	1.31	0.2–0.5
<i>Chlamida pneumoniae</i>	1.23	0.2–0.4 × 0.5–1.5
<i>Treponema pallidum</i>	1.14	0.15 × 10–15
<i>Rickettsia prowazekii</i>	1.11	0.3–0.5 × 0.8–2
<i>Chlamydia trachomatis</i>	1.04	0.2–0.4 × 0.5–1.5
<i>Mycoplasma genitalium</i>	0.58	0.2
<i>Buchnera aphidicola</i>	0.4–0.6	0.3
<i>Nanoarchaeum equitans</i>	0.49	0.4

<sup>a</sup>Million base pairs.

### Box 3.1

The obtaining of nutrients for cellular growth is dependent on the surface of the cell and the surface : volume ratio of the microbial cell. Consider the following two examples where one cell has a radius of 1 μm and another species has a radius of 2 μm.



Surface-to-volume ratio is important in small cells.

and these large organisms have adjusted to counter the low surface-to-volume ratio by having active cytoplasmic metabolism primarily adjacent to the plasma membrane. The largest bacterium is *Thiomargarita namibiensis*, which is a sulfur respiring marine coccus with a diameter of 750 μm. *Epulopiscium* spp. (Figure 2.7) are large bacterial symbionts found in the intestinal tract of certain species of tropical marine surgeonfish (Family Acanthuridae). *Epulopiscium fishelsoni* has a cell wall with many internal folds, which effectively expands the cell surface. *Thiomargarita namibiensis* and *Beggiatoa* spp. are

nonmotile bacteria that use nitrate as the electron acceptor, and since this electron acceptor may be available only transiently, the large cells enable it to accumulate nitrate to concentrations approaching 0.5 M in a central vacuole for future metabolism (Schulz and Jørgensen 2001).

While cells of eukaryotes are usually larger than cells of prokaryotes, the largest eukaryotic cell may be that of a more recently discovered protist. Matz et al. (2008) reported the presence of a giant amoeba on the sea floor at 2000 ft near the Bahamas. Called by some as “sea grapes,” the giant amoeba is about one inch in diameter. This amoeba appears to be related to *Gromia sphaerica*, found in the Arabian Sea. The giant amoeba has protoplasm on its periphery and the center of the cell is water-filled, providing buoyancy as the cell pulls itself forward on the sea floor. The amoeba moves at a rate of one inch per day and leaves grooves on the sea floor. Similar tracts were estimated to about 1.8 billion years old, and many assumed that they were the result of multicellular eukaryotic forms.

The largest mass of eukaryotic growth is the mycelium of *Armillaria ostoyae* in the forest of Oregon. As reported by Ferguson et al. (2003), the mass of the multicellular *A. ostoyae* covers 16,100 ha and a diameter of about 3.8 km. This fungus is a pathogen for conifers and the growth has been estimated to be 1900–8600 years old. This is not an isolated case of extensive subsurface fungal masses because large areas of *A. ostoyae* have been reported in dry mixed conifer forests of eastern Washington.

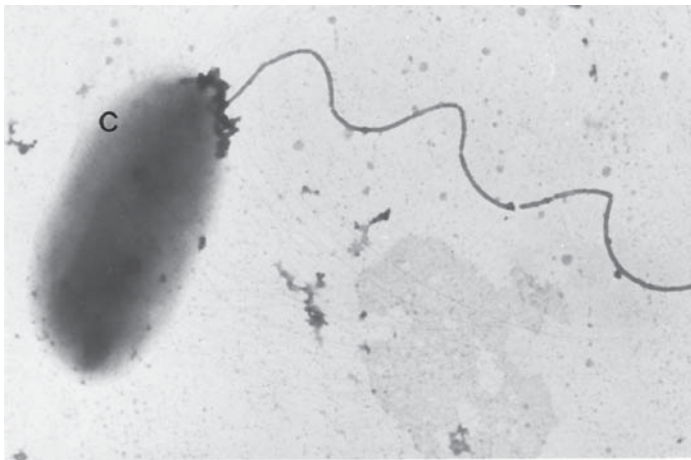
### 3.4 CELL MOVEMENT AND CHEMOTAXIS

Many of the microorganisms are capable of moving either toward or away from extracellular stimuli with the goal to position cells in an area most favorable for growth. Specialized organelles or processes contribute to the movement of individual cells, and movement of entire colonies (Ben-Jacob et al. 1998) is a possibility if the surface is moist. Some of these activities associated with motility of bacteria are presented in Table 3.2. Cilia and flagella are extracellular structures that enable microbial cells to move with cilia associated principally with animal cells and flagella found on plant and bacterial cells. With eukaryotic microorganisms, movement of cilia or flagella is attributed to ATP-driven movement of contractile fibrils. Microorganisms with cilia tend to move in a smooth arching activity without abrupt changes in direction. Sensory systems in the microorganism would account for response to a chemical stimulus, and this directed movement is known as *chemotaxis*.

Bacteria have several mechanisms that account for directed movement, best characterized by activity involved in swimming, which uses flagella. As seen in Figure 3.5, the flagellum may be several times the length of the cell. The number and location of flagella with the cell is under genetic control. In bacteria, about 50 genes are required for synthesis of the flagellum, and this protein structure has three structural segments (see Figure 3.6). One segment of the flagellum is the protein ring that originates at the plasma membrane and interfaces with sensory proteins. A central segment of the flagellum is the part that extends through the bacterial cell wall and through a set of rings secures the flagellum into the cell wall structure. The third segment is the long protein structure known as the *filament*, which is that portion of the flagellum that extends from the cell. Rotation of the flagellum is driven by protons reentering across the plasma membrane at the region of the flagellar ring secured into the plasma. The swimming activity known

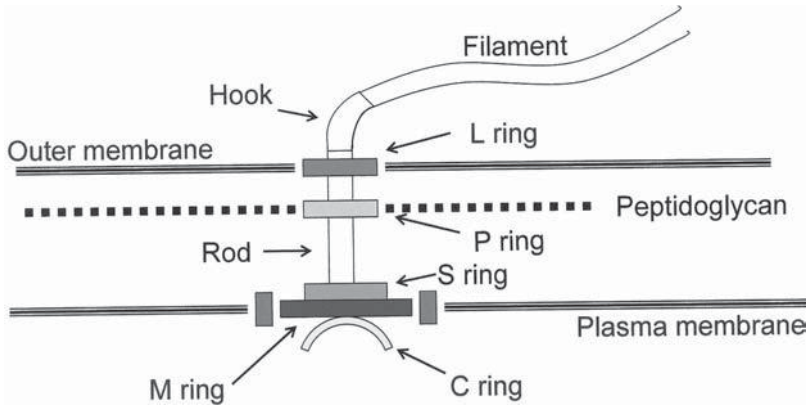
TABLE 3.2. Structures Contributing to Directed Movement of Bacteria

Activity	Structure	Characteristic
Swimming	Flagella	Random-walk motion is attributed to rotation of flagella driven by proton reentry at the plasma membrane–flagellum interface
“Corkscrew” action	Endoflagella	Flagella at ends of rigid spirochetes is located between envelope and cell wall; enables cell to move in viscous matrix
Gliding	Cell surface	Encapsulated bacteria slide across a surface by an unknown mechanism
Orientation in Earth’s magnetic field	Magnetosomes	An aggregate of $\text{Fe}_3\text{O}_4$ that is found as a small granule and frequently occurs as a chain of granules in a cell
Position in water column	Gas vacuoles	Cytoplasm of aquatic bacteria have intracellular cylinder-like structures filled with gas and regulate cell buoyancy

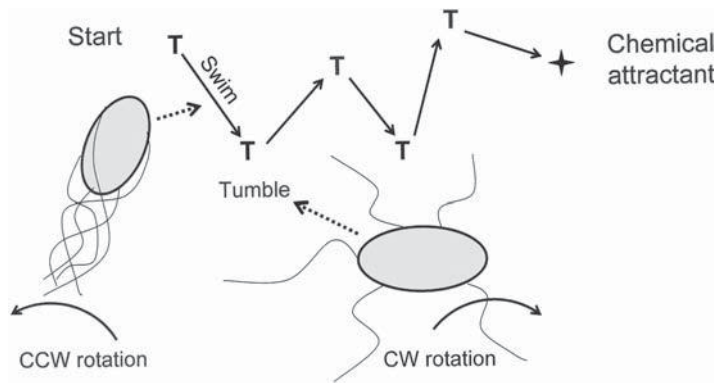


**Figure 3.5.** *Azospirillum brasilense* with a polar flagellum (magnification = 15,400 $\times$ ) (electron micrograph courtesy of Janet Shagam).

as “random walk” is associated with flagellated bacteria (see Figure 3.7), and migration of a cell toward an appropriate nutrient is positive chemotaxis. In random walk, the cell moves by alternating swim and tumble modes. In the swim phase, the flagellum rotates in a clockwise rotation, which pushes the cell forward in the liquid; in the tumble phase, rotation of the flagellum is briefly reversed to untangle flagella in multiflagellated cells. In the tumble phase, the cell senses the chemical nutrient and in the swim phase, rotation



**Figure 3.6.** Anatomy of the flagellum associated with Gram-negative bacteria.

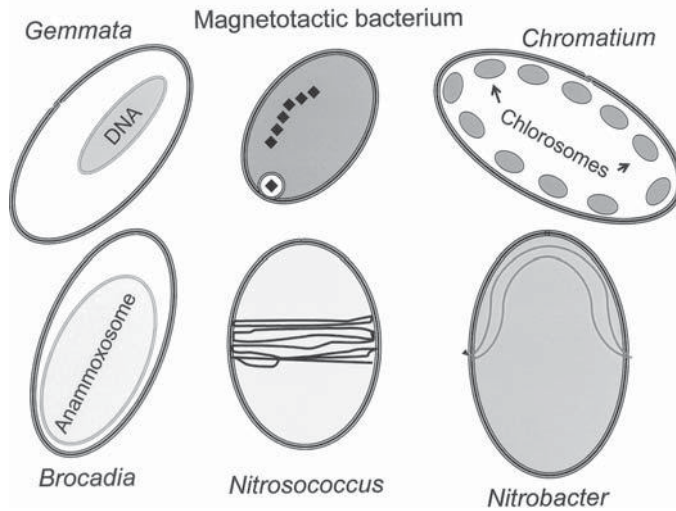


**Figure 3.7.** Random walk in bacteria displaying positive chemotaxis. Swim action is attributed to counterclockwise (CCW) rotation of flagella and tumble phase is initiated by a short clockwise (CW) rotation of flagella.

is initiated when the cell is oriented toward the general direction of the nutrient. These phases last for only a few seconds, and about 5% of the cell energy is expended on this flagellar activity.

While swimming is an important means for cell mobility, it is only one of several mechanisms. Bacteria such as spirochetes grow in mud, mucus, and other viscous environments where standard flagella would be ineffective. Spirochetes have endoflagella that are located between the cell wall and an external envelope. As the endoflagella rotate, the envelope moves and the rigid spiral rotates like a corkscrew propelling the cell forward. Gliding is displayed by several bacteria, and while the mechanism accounting for this movement is yet to be resolved, gliding by bacteria occurs on solid surfaces in a variety of moist environments.

Two additional mechanisms accounting for bacterial movement are attributed to internal cell structures. Bacteria with magnetosomes (see Figure 3.8 and Section 11.9) are found in aquatic environments where they orientate cells toward the North or South Pole and at the water–mud interface (Bazyliński and Schübbe 2007; Faivre and Schüler



**Figure 3.8.** Models of cells with cytoplasmic membranes. Nucleoid membrane as occurs in *Gemmata obscuriglobus*, magnetosomes as found in magnetotactic bacteria, chlorosomes as found in *Chromatium vinosum*, anammoxosome as occurs in *Brocadia anammoxidans*, ammonia-oxidizing membranes in the cytoplasm of *Nitrosococcus oceanii*, and membranes at the pole of *Nitrobacter winogradski*.

2008). Aquatic bacteria that do not have flagella often have internal gas vesicles to regulate their vertical position in a water column. When the vacuoles are filled with air, the cells float near the water surface because the cell density is not very great. However, when relatively little gas is present in the vacuoles, the cells sink in the water column because the cell density is increased. Cyanobacteria growing in lakes will be found on the surface of the water early in the morning because the gas vacuoles are filled with atmospheric gases. Late in the day, cyanobacteria are found lower in the water column because carbon dioxide is consumed from the gas vesicle and the cell density increases. The advantage of this change of position in the water is that nutrients may be stratified in water, enabling cyanobacteria to obtain nutrients from numerous levels in the lake.

### 3.5 STRUCTURES OF SPORULATION

Unlike vegetative cells that have a high level of metabolism and undergo cell division, resting cells or nongrowing units enable the microorganism to persist when the environment is not supportive of cell growth. Sporulation is not a mechanism of reproduction because a single bacterial cell produces a single spore (Figure 3.1B). In bacteria, all resistive structures are asexual, and examples of these are given in Table 3.3.

A range of resistances is observed in microbial resting cells; the most resistant is the bacterial endospore produced by only a few genera. Unlike bacterial cysts, conidia, or other resistive structures, the endospore is not destroyed by dry heat; this characteristic is attributed to the presence of calcium dipicolinic acid, which serves as a desiccant and removes free water from the cytoplasm. Since heat inactivation of cells is attributed to



TABLE 3.3. Resistant Structures Produced by Bacteria

Structure	Produced by <sup>a</sup>	Characteristics
Endospore	<i>Bacillus, Clostridium</i>	The most resistive spore produced by bacteria; resists heat, strong acids, bases, and toxic chemicals
Akinete	Cyanobacteria	A differentiated cell in the trichome that is not involved in photosynthesis of vegetative growth but resists freezing and drying
Bacterial conidia	<i>Streptomyces</i>	A resistive structure produced at the end of the filament of these soil bacteria; structural surfaces are unique and often used in identifying type of bacteria; structure is resistant to freezing and drying
Bacterial cysts	<i>Azotobacter, Azospirillum</i>	Produced by soil bacteria; cysts are resistant to freezing and drying

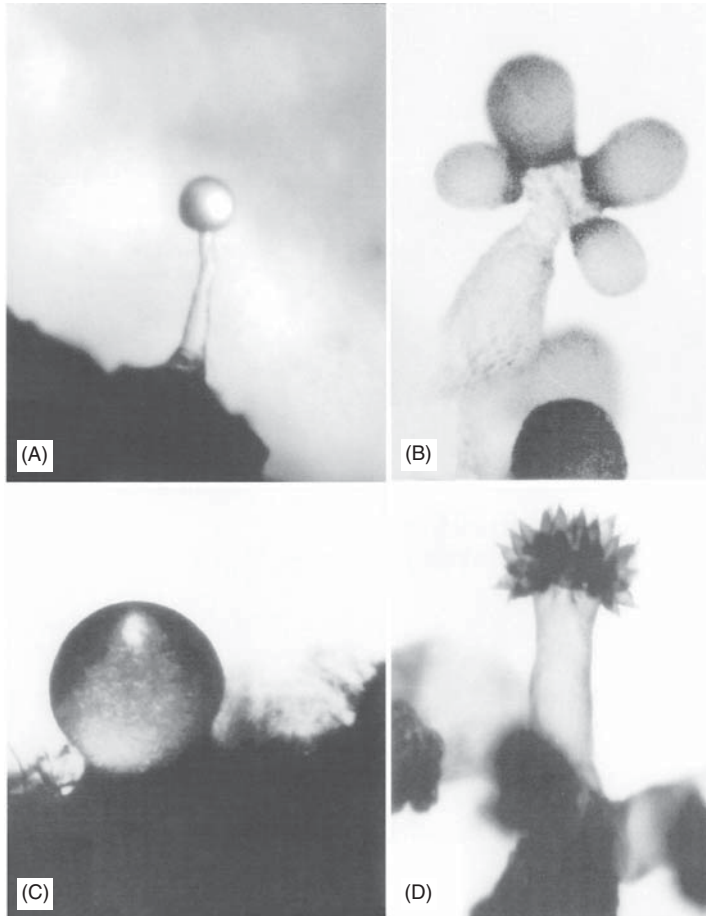
<sup>a</sup>Many species are capable of production of these resistive structures, but only a few species are listed.

destructive activity of hot water, endospores are not subjected to thermal denaturation. Endospores, cysts, and conidia are produced by bacteria as a response to the environment, and production of resistive structures is not a mechanism of reproduction. Because the number of genes for sporulation is large and dispersed around the bacterial chromosome, lateral gene transfer will not result in recipient cells producing endospores.

Several different bacterial genera found in soil environments have specialized structures that are bacteriocysts or bacterioconidia. These resistive structures have a minimal amount of metabolism and enable the bacteria to persist as the soil dries or freezes. Bacteria, such as *Azotobacter*, grow in the soil and an individual cell differentiates to produce a spherical cyst. Another soil bacterium, *Streptomyces*, grows with filaments consisting of many cells and in response to changes in the soil environments, cells at the end of the filament differentiate into a chain of several resistive structures referred to as *bacterial conidia*. The structural features of these conidia are sufficiently distinctive and can be used to assist in identifying the different species.

One remarkable characteristic of a physiological group of bacteria is the formation of spores on a multicellular fruiting body (Figure 3.9). *Myxococcus xanthus*, a fruiting-body-producing bacterium, displays considerable cellular differentiation and has a lifecycle (Figure 3.10) similar to that of eukaryotic slime molds. The vegetative cells are coprophilic growing on decomposing plant material and divide by binary fission to produce additional cells. In response to drying or other environmental stimuli, the cells move by a gliding mechanism to produce a fruiting structure with a differentiated stalk and globular masses of myxospores. The stalk may consist of  $10^9$  cells, and this aerial structure may be 600  $\mu\text{m}$  in height. Air currents disperse the myxospores, and if the new environment is favorable, the myxospores will germinate to produce vegetative cells and the lifecycle will continue. Because of the cell–cell interaction associated with the production of the fruiting structure, these bacteria are often referred to as “social” bacteria. The process of developing a fruiting structure requires a considerable number of genes to enable the developmental process to occur (Plamann and Kaplan 1999; Shimkets and Kaiser 1999). The single chromosome of *M. xanthus* is 9.5 Mbp, which is

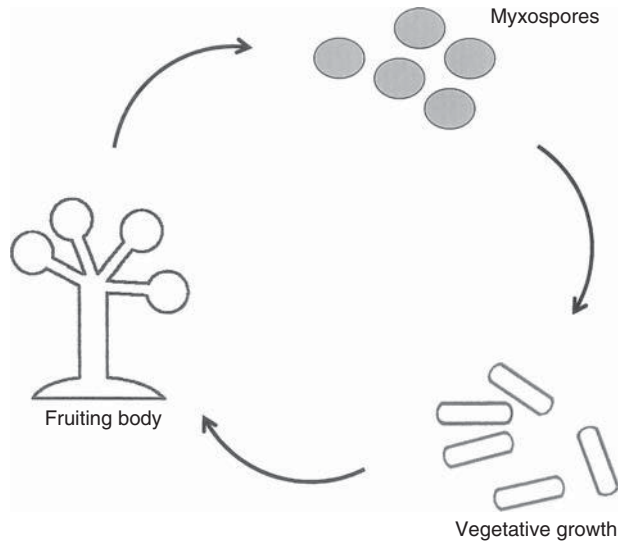




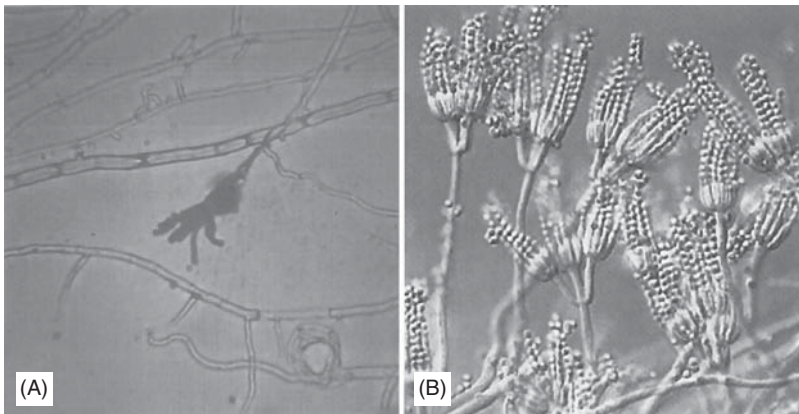
**Figure 3.9.** Distinctive aerial structures of fruiting body bacteria: (A) *Myxococcus stipitatus*; (B) *Myxococcus* sp.; (C) *Stigmatella aurantiaca*; (D) *Chondromyces apiculatus* (photographs courtesy of Martin Dworkin).

twice the amount of DNA in *E. coli* and two-thirds the amount of DNA found in the 16 chromosomes of yeast.

Many of the eukaryotic forms of microorganisms contain both sexual and asexual spores. The multicellular soil fungi produce thousands of asexual spores on aerial structures as part of their reproductive strategy. Examples of asexual spore production by *Penicillium* spp. are given in Figure 3.11. These asexual spores are more resistant than vegetative cells and remain viable even when dispersed by wind currents. Resistive structures produced as a result of sexual activity involving two separate partners are found in fungi and algae. Aquatic fungi and brown marine algae have complex lifecycles involving microbial partners of different sex (e.g., male and female) to produce the resistive structure. Some soil fungi have partners of the same species that are referred to as “plus” and “minus.” The eukaryotic sexual resistive structure not only enables species to persist when growth may not be favored but also is an opportunity for genetic mixing.



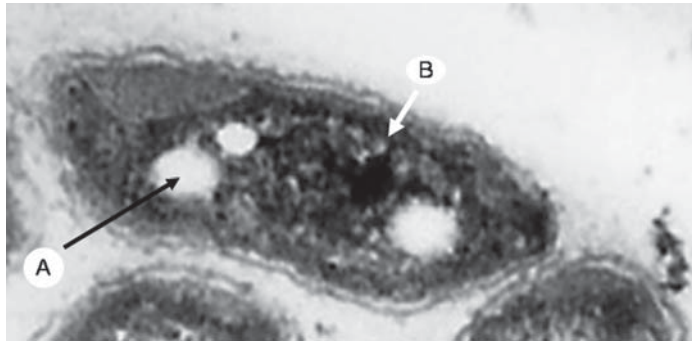
**Figure 3.10.** Lifecycle of *Myxococcus*.



**Figure 3.11.** Asexual fruiting structure of *Penicillium* sp.: (A) spore-bearing structure produced from septated mycelium; (B) individual spores produced at the tip of a specialized fruiting structure (photographs from *Ward's Natural Science* used with permission). See insert for color representation.

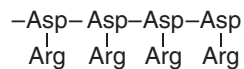
### 3.6 NUTRIENT RESERVES AND STORAGE MATERIALS

In natural environments, there is considerable change in available nutrients as microorganisms are subjected to “feast to famine” situations. Microorganisms have the capacity to accumulate nutrients within the cell when they are available and to use these stored materials when they are limiting in the environment. The major storage materials include carbon, nitrogen, or phosphorus compounds or minerals used in cell energetics. Not all microorganisms accumulate the same items or the same type of reserve, but each



**Figure 3.12.** Electron micrograph of a bacterial cell with internal structures: (A) polyglucose and (B) gas vacuole (photograph provided by Larry Barton).

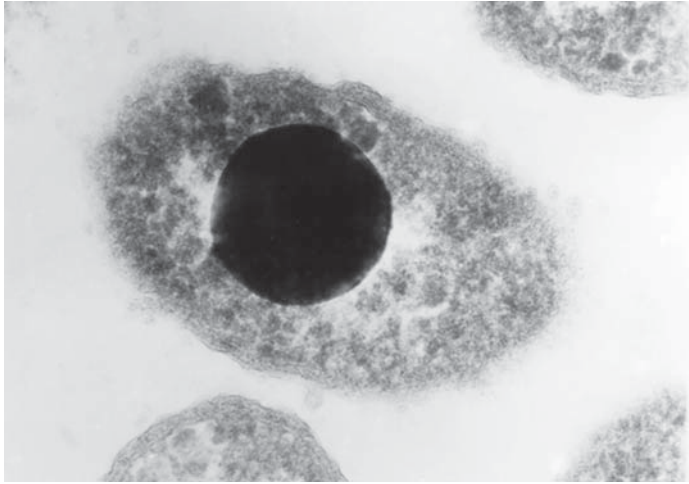
species has a mechanism for nutrient storage. When carbon source is in excess, bacteria may accumulate intracellular storage granules of glycogen (Figure 3.12) or polymers of  $\beta$ -hydroxybutyric acid. Algae accumulate a variety of carbohydrates; the most common are starch, mannitol, lammarin ( $\beta$ -1,3-glucose polymer), and oils. Under conditions of high nitrogen fixation and slow growth rates, many cyanobacteria will accumulate cyanophycin, which is a copolymer of arginine (Arg) and aspartic acid (Asp). The molecular composition of cyanophycin is as follows:



Granules of polyphosphate are often found in the cytoplasm of bacteria as a discrete electron-dense structure (see Figure 3.13). When inorganic phosphate is present in the environment and an appropriate carbon substrate is limiting, accumulation of phosphate as polyphosphate occurs. When phosphate becomes limiting in the environment, phosphate is used from the polyphosphate granule for phosphorus nutrition. Intracellular accumulation of elemental sulfur occurs as globules in some chemolithotrophic and phototrophic bacteria that use hydrogen sulfide as an electron donor. When sulfide becomes limiting in the environment, elemental sulfur in the globules serves as an electron donor with the production of sulfate. Unlike eukaryotes, bacteria do not have internal structures delineated by a lipid-protein membrane.

### 3.7 CELL-CELL ASSOCIATIONS

Microorganisms in the environment are rarely uniformly dispersed but are often immobilized in microcolonies. Except for aquatic environments where nutrients are in solution, bacteria and other microorganisms cluster at the region where growth is most favorable. In soil, mud, hot springs, and thermal vents, organisms collect as biofilms consisting of numerous different species. For the most part, microorganisms grow on the surface of



**Figure 3.13.** Electron-dense polyphosphate granule inside a bacterial cell; note the absence of a membrane around the polyphosphate granule (electron micrograph provided by Larry Barton).

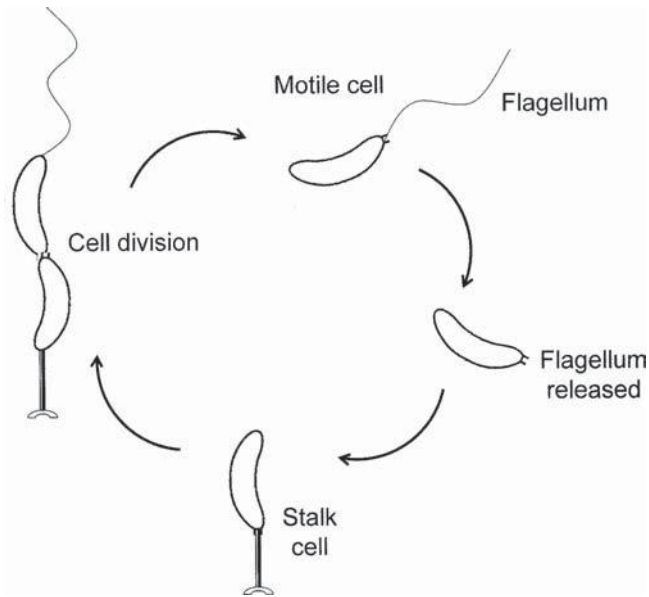
environmental structures, and this could include rocks, plant roots, teeth, and various animal tissues. While the dispersion of organism in the environment may be somewhat random, this aggregation or attachment reflects a preference on the part of the microorganism for an environment, and this specificity reflects adaptations at the cell surface to recognize chemicals making up the surface where attachment occurs. The following examples will serve to illustrate this specificity on the part of the bacteria.

### 3.7.1 Cell Attachment

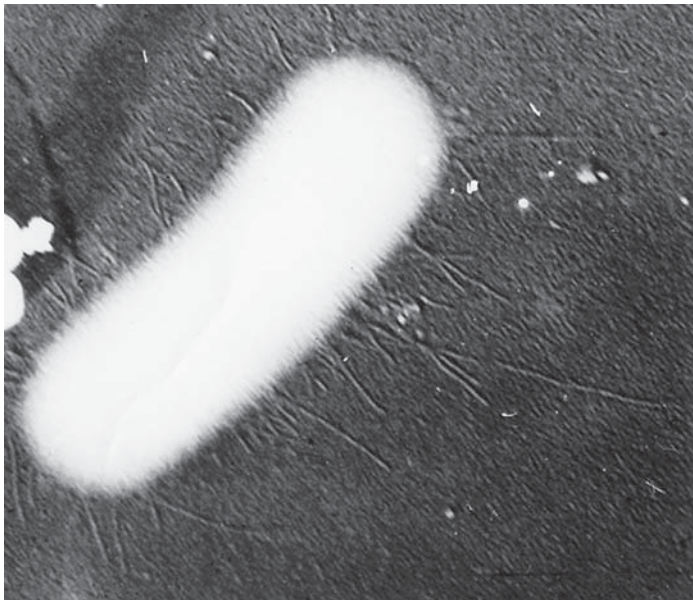
*Caulobacter* is a bacterium that has developed a strategy for growing in dilute aquatic environments by attaching the cell to the surface and acquiring nutrients as the water flows past. As presented in Figure 3.14, *Caulobacter* has a lifecycle that starts with a swarmer cell that employs a flagellum to propel it through the water. Using a chemotactic response, the swarmer cell migrates into a favorable environment where the cell loses the flagella and develops a stalk at one end of the cell. At the tip of the stalk is a holdfast that attaches to rocks or other surfaces and tethers the cell to the surface. With the acquisition of nutrients, the immobilized cell divides and the new flagellated cell swims away. Only the immobilized cell is capable of cell division. (See Section 1.5.1 for a discussion about curvature of the *Caulobacter* cell.)

Chemolithotrophic bacteria grow by obtaining energy from minerals, and cells attach to the appropriate inorganic compounds in the environment. *Shewanella* is a bacterium that grows with organic compounds as the electron donor and  $\text{Fe}^{3+}$  as the electron acceptor. At one end of the *Shewanella* cell there is a cluster of several short structures designated as type 4 pili that specifically attach to oxidized iron minerals in the environment. This immobilizes the *Shewanella* cell on the surface of the mineral that is ultimately reduced.

Bacteria associated with disease production in humans have uniquely specific attachment mechanisms to localize the pathogen in the appropriate tissues (Cossart et al. 2000). Pathogenic *Escherichia coli* have specific pili (Figure 3.15) on the surface of the bacterial



**Figure 3.14.** Lifecycle of *Caulobacter*, a stalked bacterium. Motile cells swim to a favorable environment where they produce a stalk and become attached. The attached cell acquires nutrients from the stream flowing past it.



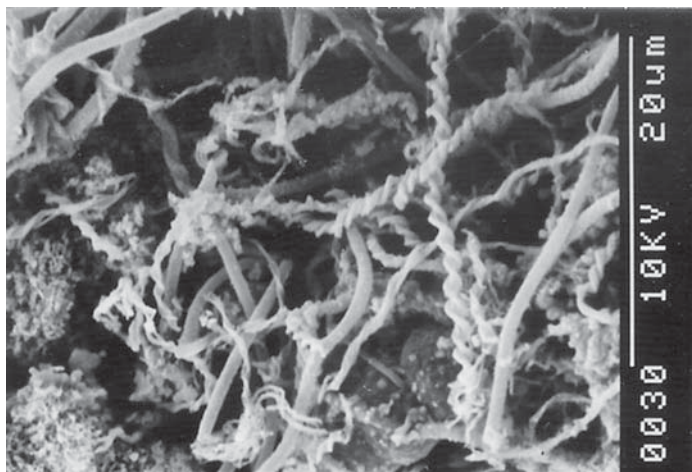
**Figure 3.15.** Electron micrograph showing pili on surface of *Escherichia coli* cell (photograph courtesy of Sandra Barton).



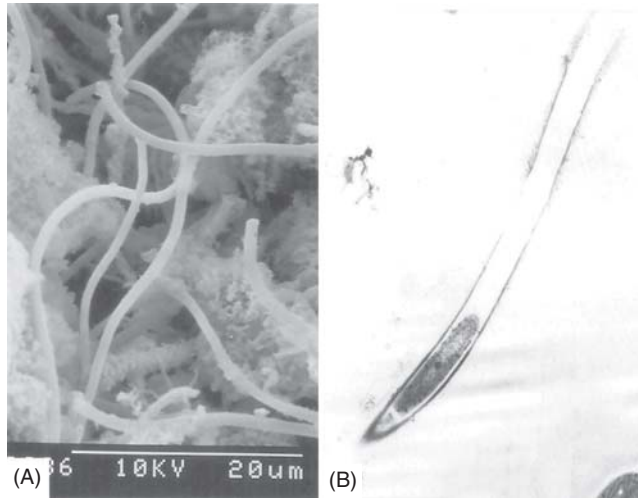
cell, and at the tip of each pilus is a lectin-like protein that recognizes the carbohydrates on the surface of the host animal cell. Other bacteria may have pili specific for tissues where the pathogen may become localized and initiate an infection. Bacteria that do not use pili may use unique proteins on the surface of the bacteria cell to attach the bacterium onto the appropriate host cell. Proteins for attaching pathogens onto the surface of host cells may be referred to as *adhesins*, and this localization process is important for initiation of whooping cough, rheumatic fever, plague, gonorrhea, and other bacterial diseases.

### 3.7.2 Biofilms

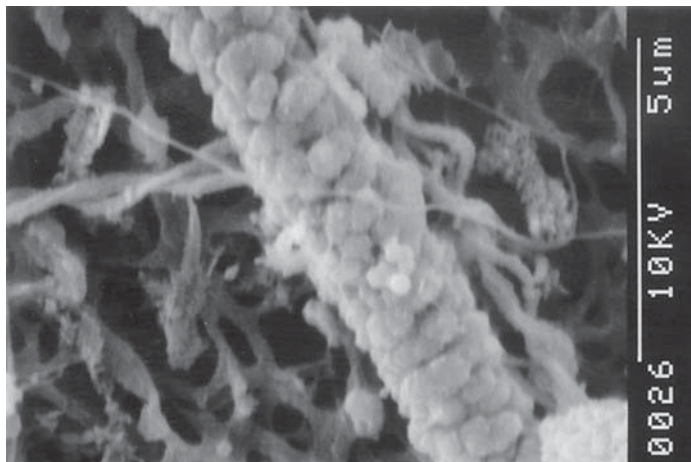
Microorganisms may colonize and grow on surfaces to form mat-like covering often referred to as a *biofilm* (see Section 9.4 for a discussion of biofilms). If a biofilm is detrimental or a nuisance, it generally is described as a *biofouling* process. The development of a biofilm can be characterized as occurring in several phases. The first step is the attachment of organic compounds from the environment to a wet surface. The adsorbed organic molecules provide a suitable surface for attraction and attachment of bacteria in the development of the biofilm. As a result of sensory response to immobilized organic materials onto a surface, bacteria are attracted and move by positive chemotaxis to the developing biofilm. Examination of a subsurface biofilm in an aquifer reveals microorganisms of various morphologies, including spirochetes (Figure 3.16) and filaments of bacteria. In some cases bacteria are adsorbed onto the surface by ionic or hydrogen bonds (Figure 3.17). The mechanism of this cell–cell interaction (Figure 3.18) may be attributed to binding attributed to the extracellular polymeric matrix (EPM) or proteins on the cell surface (Figure 3.19). The immobilized cells secrete capsular material that contribute to EPM, due to the entrapment of nitrogenous compounds, biomolecules from cell lysis, and metal ions from the environment. Lateral gene transfer is enhanced by the entrapment of DNA in the EPM. In nature, biofilms consist of mixed microbial cultures but rarely contain paramecium because these protozoa reverse ciliary action when



**Figure 3.16.** A subsurface anaerobic biofilm containing a mixture of bacteria; spirochetes and bacterial filaments are prominent in the biofilm (image provided by Larry Barton).



**Figure 3.17.** Biofilms on an inflow pipe showing a diversity of attached bacteria: (A) abundance of filamentous and sheath-containing bacteria; (B) thin section through a sheath showing bacteria present inside (electron micrographs provided by Larry Barton).

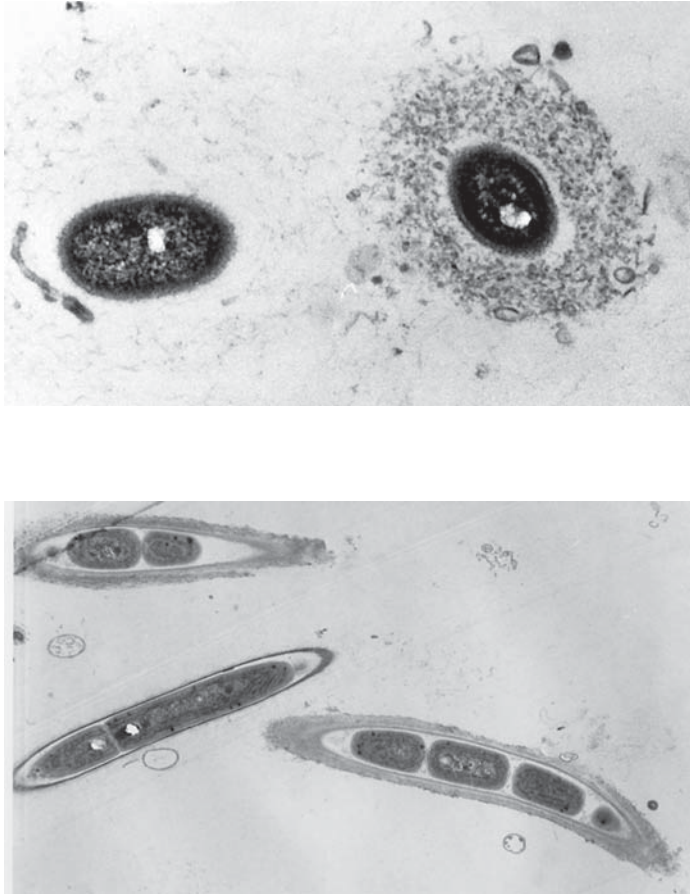


**Figure 3.18.** Interactions between bacteria in a biofilm; spherical bacteria are attached to a filamentous bacterial cell resembling kernels in a corncob (electron micrograph provided by Larry Barton).

they encounter a solid surface. Filamentous microorganisms are favored in the biofilm because the cell aggregates extend into the stream to acquire nutrients. Diatoms are adsorbed onto the substratum by mucilage secreted from the microalgal cell with ionic interactions attributed to the presence of  $\text{Ca}^{2+}$ .

In the biofilm there are various types of interaction between the biotic and abiotic components. Chemolithotrophs and autotrophs interact with heterotrophs to provide competition between populations of producers and consumers. Anaerobic phototrophic





**Figure 3.19.** Extracellular polymeric matrix (EPM) present around an aquatic bacterium; proteins and other biological materials in the water are trapped in the EPM; one cell in the figure lacks EPM (electron micrograph provided by Larry Barton).

organisms grow near the surface of the biofilm, producing  $O_2$  that may accumulate especially if diffusion is restricted by thick EPM. The oxygen-rich environment favors rapid growth of aerobic organisms, and as the  $O_2$  level declines, growth of facultative heterotrophs and anaerobic chemolithotrophs occurs. Metabolism of sulfate-reducing bacteria releases hydrogen sulfide to produce a strongly reducing environment, and this anaerobic environment may be favorable for nitrogen fixation. Competition for limiting nutrients may stimulate a starvation stress response with certain bacteria producing bacteriocins or antibiotic-like substances.

In thick biofilms growth is influenced by microbial interaction with the microenvironment. A biofilm may have specific regions where growth reflects physical or biological regulation. Cracks or crevices in the biofilm result in patchy growth with microcolony development producing microislands of a specific species within the biofilm. An increased growth of biofilm may physically restrict fluid flow resulting in the selection of specific microorganisms. These islands of microbial development enable us to understand the aerobic–anaerobic nature of biofilms. In a single biofilm there may be aerobic nitrification

and anaerobic denitrification as well as sulfur oxidation and reduction. There is also an interaction between organisms making up the biofilm and bacteria dispersed in the water flowing past the biofilm. The succession of microorganisms in a biofilm and the release of materials from the biofilm may be attributed to the types and numbers of microorganisms dispersed in the fluid.

### ***Microbial Spotlight***

#### **GILL GEESEY**



Working with one of the giants of microbiology, Claude Zobell, started Gill Geesey off on his interest in microbiology, and sulfate-reducing bacteria (SRB) in particular, as an undergraduate at the University of California—San Diego. This interest blossomed into a career that has led to many discoveries of how microorganisms play major roles in the geosphere. During some early experiments, Gill cultivated SRB on the mineral hematite, where the SRB formed biofilms, using nutrients supplied in a continuous flow reaction. As Gill describes it:

After about two weeks, we stopped the experiment and looked at the mineralogy underneath the biofilm using some interesting surface analytical chemical instrumentation. We found that a rather novel mineral, pyrrhotite, was deposited on top of the hematite. Up until that time it was thought that pyrrhotite was only formed under relatively extreme conditions that life wouldn't normally exist under. That was something that caught our attention and led us to speculate that microorganisms might play a larger role in forming the geosphere than geologists had previously thought.

This speculation has expanded to include the underlying cell biology and genomics of microbial biofilm members. Gill notes that

We're more interested in understanding how the behavior of the organism changes on the hematite surface when you knock out some of the genes that have been shown to be important for participating in respiration on that mineral. We have found that knocking out a respiratory gene changes the ability of the bacterium to accumulate as a biofilm over time. Also, it seems to promote detachment of cells from the hematite surface. Bacteria probably use some of those proteins for sensing and if the environment that they're in is suboptimal, that sensing function encourages them to detach from that surface and look elsewhere for a better environment.

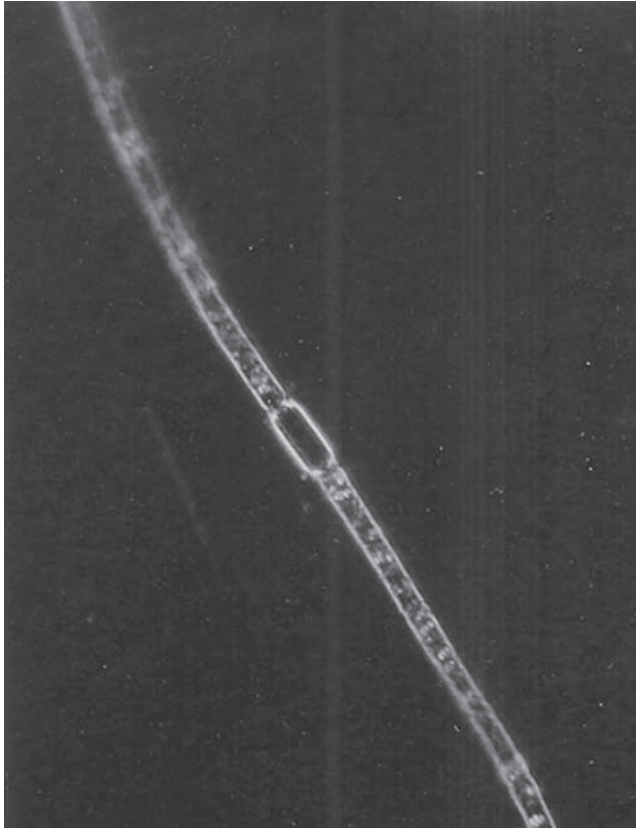
Out of the lab, and into the environment, Gill's work in Yellowstone National Park, led to the discovery that

If you go to different locations with slightly different chemistries and temperatures and pH, and you look at sequence of certain key genes that allow these organisms to compete in this environment to be part of this community, the gene sequence appears to be controlled by certain environmental parameters. So as you go down a chemical gradient, the gene sequence changes in a predictable way in terms of dissolved organic carbon concentration, temperature and pH. You can kind of study how genes evolved if you have the right kinds of changing environmental conditions where those genes exist today.

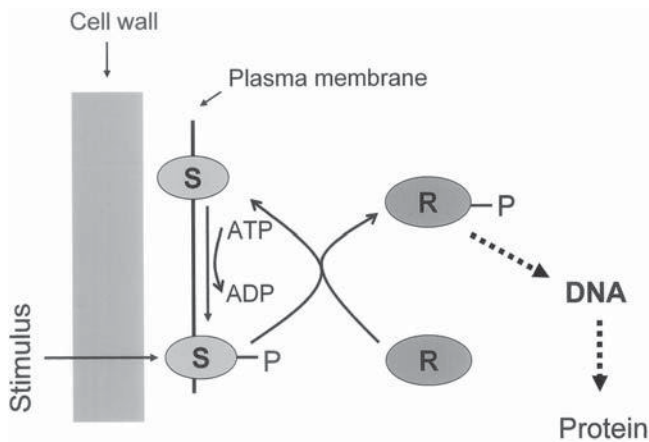
Gill Geesey manages to combine environmental gradients, genes, and geomicrobiology to reveal the mysteries of how microorganisms interface with geology.

### 3.7.3 Filamentous Growth

Some bacteria, algae and fungi grow in filaments resulting from cells remaining attached following cell division, and microorganisms with filamentous growth may have a nutritional advantage over individual cells. With fungi and actinomycetes, cell division occurs at the tip of the linear filament and growth permeates the porous environment where nutrients are present. Nutrient transfer in the filament occurs with coenocytic fungi (e.g., *Mucor* and *Rhizopus*), where fungal cells are not divided by transverse cell walls. In the case of mycorrhiza where fungi are associated with plant roots, the mycorrhizal fungi also facilitate the transfer of nutrients from the rhizosphere to the plant symbiont. Another aggregation of bacterial cells is observed with sheath producing bacteria such as *Sphaerotilis* and *Leptothrix*. In aquatic environments the straw-like sheath containing the cells increases in length and binds nutrients that support growth of the cells (see Figure 3.19). Many cyanobacteria grow as filaments (see Figure 3.20), and when a specialized cell in the filament fixes nitrogen, the entire filament benefits. *Ancaelomicrobium* is a genus of unusual bacteria that grow by a budding process, where the buds do not become released from the parent cells but are attached by a thin interconnecting structure. Various aquatic bacteria and fungi can form long filaments that become entangled with cellular structures that are used as nutrients to support the growth of the filamentous microorganisms.



**Figure 3.20.** Cyanobacterial filament showing a specialized cell (heterocyst) used for nitrogen fixation. (Picture provided by Larry Barton).



**Figure 3.21.** Model of two-component sensory system in bacteria: S = sensory protein in the plasma membrane; P = receptor protein in the cytoplasm; S-P = phosphorylated sensory protein; R-P = phosphorylated receptor protein (R-P influences gene expression by interaction with DNA).

### 3.8 CELL PHYSIOLOGY AND METABOLISM

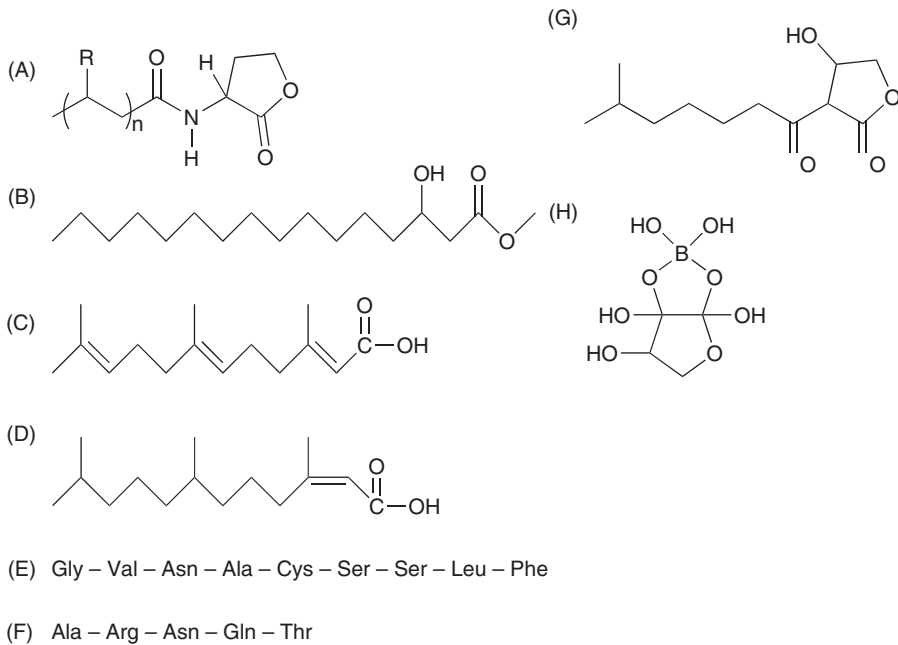
The physiological type of microorganisms in a specific area is a result of both environmental selection and microbial response. If it is a sunny aquatic environment, photosynthetic organisms may dominate, while in a confined environment containing organic matter, fermentative bacteria are in high concentrations. The type of microorganism growing in an area is in part a consequence of selective growth response. Collectively, microorganisms have a broad range of metabolic activities, and microorganisms growing in a given environment are those that respond to the physical and chemical stimuli from that environment. Dominant microorganisms display appropriate sensory response, global regulation of DNA expression, membrane organization, and enzyme capability. The following section explores some of the microbial characteristics.

#### 3.8.1 Sensory Response

One of the characteristics of life is the ability to respond to stimuli, and bacteria have a highly efficient sensory–signaling system. Chemicals released by plants, animals, or other bacteria may serve as stimuli for bacteria to influence bacterial movement, metabolism, or development of cell structures. Physical stimulus, as in the case of osmotic pressure, may also illicit changes in the bacteria. Not all bacteria in the area of the stimulus will respond, but if a bacterial cell has the response capability, it may benefit by experiencing increased growth. Also it should be noted that each bacterial species may have a different response to the same stimulus. In other words, increased osmotic pressure may promote toxin production by *Vibrio cholera*, capsule synthesis by *Pseudomonas aeruginosa*, or synthesis of a new porin in the outer membrane of *Shigella flexneri*.

While there are several different types of sensory response in bacteria, the two-component system is used by many different bacteria to respond to stimuli (Hoch and Silhavy 1994). The transduction of the signal (stimulus) across the membrane of bacteria involves interaction of the signal with a sensory protein in the plasma membrane see Figure 3.21. A conformational change in the sensory protein is initiated by the chemical or physical stimulus, and the phosphorylated sensory protein transfers the phosphate group to the cytoplasmic receptor protein. The phosphorylated receptor protein interacts with DNA to stimulate gene expression, and a new protein is produced. The function of this new protein becomes important in the response of the bacterial cell to a specific stimulus. The number and diversity of stimuli recognized by bacteria are numerous, and a few are listed in Table 3.4. Signal response by bacteria has important consequences because toxin production by most pathogenic bacteria is triggered by the host. Stimuli provide for selective expression of the cellular DNA, and, therefore, biosynthetic energy is conserved because expression does not occur unless there is some benefit for the cell.

A more complex issue pertaining to signal response is associated with internal processes. In sensory response having more complexity than the two-component system, there may be numerous interactions with the phosphorylated receptor protein. For example, the phosphorylated receptor protein may coordinate positive chemotaxis toward a sugar and interact with sugar transport systems in the responding bacterial cell. This fine control of chemical sensing contributes to cellular efficiency and energy conservation. The sensory systems of bacteria are extremely complex and in some bacteria a sizeable segment of the bacterial genome may be associated with sensory activities.



**Figure 3.22.** Examples of chemicals that are used by microbes for cell–cell communication in quorum sensing (most of these are for virulence or cellular development): (A) acylhomoserine lactone molecules produced by various Gram-negative bacteria; (B) hydroxypalmitic acid methyl ester associated with *Ralstonia solanacearum*; (C) farnesoic acid produced by *Candida albicans*; (D) methyl dodecenoic acid with *Xanthomonas campestris*; (E) peptide for toxin production by *Staphylococcus aureus*; (F) sporulation signal used by *Bacillus subtilis*; (G)  $\gamma$ -butyrolactone used by several *Streptomyces*; (H) furanosylborate produced by *Vibrio harveyi*.

**TABLE 3.4.** Examples of Sensory Systems in Bacteria

System	Stimulus
Chemotaxis	Chemicals attract or repel swimming bacteria
Spore production	High cell density or increased pH or temperature
Rhizobial symbiosis	Chemicals secreted by plant roots
Porin production	Increased osmotic pressure
Resistance to heavy metals	Presence of metals at sublethal concentration
Toxin production	Changes in pH, temperature, or osmotic pressure
Production of extracellular protease or amylase	Deficiency of chemicals for metabolism in environment
Assimilation of nitrogen	Influenced by nitrate or ammonium present
Capsule synthesis	Increase in osmotic state
Redox response in heterotrophs	Oxygen concentration in environment



A unique sensory process in prokaryotes is *quorum sensing*, which initiates gene expression only when an optimal cell density is achieved. Basically, bacteria of a specific species produce a chemical at low concentration that is exported into the surrounding environment and is not readily metabolized by other microorganisms in that environment. When enough bacterial cells are present to produce the same chemical, the concentration of the sensory chemical is sufficiently great to account for import into the cell originally exporting the chemical. The imported chemical induces DNA expression to produce new physiological activities. Examples of some of these inducer molecules produced by bacteria for quorum sensing are given in Figure 3.22. Bacterial changes attributed to quorum sensing include toxin production, metabolism of inorganic iron, and production of endospores. Quorum sensing in bacterial luminescence is discussed in Section 8.5.

### 3.8.2 Global Regulation

Expression of DNA in prokaryotes is highly regulated so that only the proteins required for growth in that specific environment are produced at that time. Some enzymes required for basic synthesis of cellular structures and for metabolism are produced continuously and without restrictions in a process referred to as *constitutive protein synthesis*. Enzymes for substrates that are infrequently present in the environment or proteins for cell activities that are in response to a stimulus are highly regulated; these are referred to as *inducible proteins*. Genes for a common function are often clustered together on DNA in regulatory units referred to as *operons*. Induction is a powerful process because it can account for the production of new proteins in a very short time. By controlling the operons expressed, bacteria can regulate the amount of energy used to produce a new cell. As indicated in Table 3.5, protein synthesis requires more energy than do other cell processes. Thus, regulation of protein synthesis enables bacteria to conserve energy, and ATP can be reserved for synthesis of new cells.

To coordinate gene expression, two or more separate but related inducible operons may be controlled by the same regulatory protein; this type of expression is referred to as a *regulon*. In addition to the regulatory proteins controlling operons and regulons, there may be another level of regulation. This highest level of DNA expression is a *modulon*, and each prokaryote cell may have one to several modulons. The modulon provides a second layer of regulation to the original inducers for the operons and regulons, and this coordinated expression of multiple genes simultaneously contributes to global regulation. Several examples of global regulation in bacteria are listed in Table 3.6. A key component

TABLE 3.5. Energy Required for Synthesis of Biostructures by *E. coli* Dividing with a Doubling Time of 20 min

Molecule or Activity	Percentage of Cell Composition	Percentage of Total Biosynthetic Energy Required
Protein	52.4	51.8
Lipo/polysaccharide	16.6	15.0
RNA	15.7	13.0
Lipid	9.4	3.7
DNA	3.2	2.5
Solute transport	—	15.0

Source: Modified from Barton (2005).



TABLE 3.6. Examples of Global Regulation in Bacteria

System	Number of Genes Involved <sup>a</sup>
Aerobic respiration	>50
Anaerobic respiration	>70
Catabolite repression with cAMP	>300
DNA repair by SOS response	>20
Heatshock response	>36
Oxidative stress	>30
Nitrogen utilization	>12

Source: Modified from Barton (2005).

TABLE 3.7. Sigma Factors Produced by *E. coli*

Sigma Factor	Function
$\sigma^{70}$	Responsible for production of proteins under nonstressed conditions; considered to transcribe genes for “housekeeping” activities; the major sigma factor in growing cells
$\sigma^{54}$	Associated with nitrogen assimilation and is produced as a result of nitrogen deficiency
$\sigma^{38}$	Produced during stationary phase and in cells under nutrient stress; also found in cells that are growing under increased osmotic pressure and oxidative stress
$\sigma^{32}$	Associated with heatshock response
$\sigma^{28}$	Associated with genes in biosynthesis of flagella and for chemotaxis
$\sigma^{24}$	Produced in response to improperly folded proteins in periplasm (region between outer membrane and plasma membrane in bacteria)
$\sigma^{14}$	A function known to participate in iron uptake

in modulon control is the *sigma factor*, a subunit of RNA polymerase, which recognizes a specific base sequence (promoter) on the DNA for initiation of RNA synthesis. When a stimulus induces production of a new sigma factor, a large number of genes are induced. In response to stimuli, *E. coli* has seven genes that produce different sigma factors (see Table 3.7), and it may be assumed that each species of bacteria also has the genetic basis to produce several different sigma factors.

### 3.8.3 Internal Membranes in Bacteria

Cells of eukaryotes unlike prokaryotes have a highly developed arrangement of intracellular membranes. With the current hypothesis that eukaryotic cells evolved from prokaryotic cells, it would be expected that there is some evidence for internal membrane development in prokaryotic cells. It would be consistent with Darwinian evolution that prokaryotic cells with internal membranes would have a competitive advantage. Many prokaryotes have internal granules (e.g., polyphosphate granules,  $\beta$ -hydroxybutyric acid polymers, polyglucose granules), but these structures are surrounded by a layer consisting only of protein that contains enzymes for granule development. A few bacteria show evidence of membranes in the cytoplasm of the cell, and these membranes have a special function in metabolism. Examples of these internal membranes are given in Figure 3.8.

In several of the nitrifying bacteria, photosynthetic bacteria, and methane-oxidizing bacteria, laminar membranes are present along the periphery of the cell (Figure 3.8).

The photosynthetic membranes of cyanobacteria, referred to as *thylakoids*, contain the light-harvesting system and are arranged in a series of membranes parallel to the plasma membrane. The photosynthetic anaerobic bacteria have membranes that appear as lamellar, vesicles, and tubes (Oelze and Drews 1981). Oxidation of ammonia is a challenge for anaerobic bacteria, and the anammox system of *Brocadia anammoxidans* utilizes the anammoxosome, which is a membrane-enclosed cytoplasmic unit. Magnetosomes produced by bacteria are surrounded by a membrane that originates from invagination of the plasma membrane as the magnetic structure is formed. A distinct membrane that is present in *Gemmata obscuriglobus* is analogous to a nuclear membrane in eukaryotes in that it encloses the cell DNA; however, the genetic material is prokaryotic DNA. *Nitrosococcus* sp., an  $\text{NH}_3$  oxidizer, and *Nitrobacter* sp, a  $\text{NO}_2^-$  oxidizer, are phylogenetically related to purple phototrophs and methylotrophs. Additionally, the *Brocadia* and *Gemmata* are members of the same Planctomyces group. Although not all bacteria have true membrane in their cytoplasm, the presence of internal membranes may have developed at several different times in evolution as bacteria optimized metabolic activities.

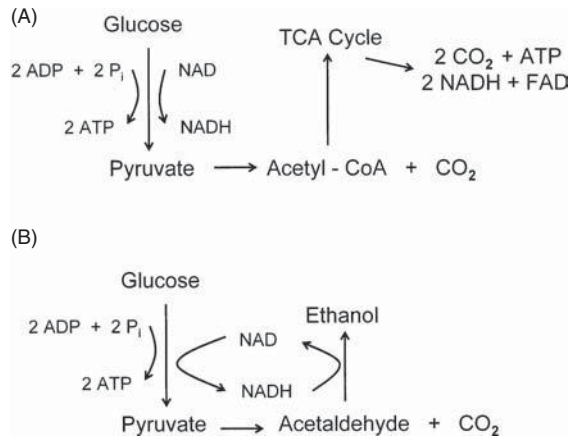
### 3.9 ENERGETICS AND ENVIRONMENT

Microorganisms use biosynthetic reactions to synthesize the various materials for cell growth, and energy in the form of ATP is used to drive the reactions. Thus, for microbial growth, ATP must be produced, and there are three major mechanisms for producing ATP in biological systems: (1) oxidative phosphorylation, (2) substrate-level phosphorylation, and (3) photophosphorylation. The processes used for ATP synthesis in microorganisms are similar to those found in plants and animals; however, the reactions found in bacteria and archaea are more diverse than those found in higher life forms. The following discussion is intended to provide insight into the energy-producing capabilities of bacteria and archaea.

#### 3.9.1 Heterotrophs

Widely dispersed in the biosphere are heterotrophs that use organic compounds synthesized by microorganisms, plants, or animals as a source of carbon and energy. While sugars are the principal energy-yielding compounds, amino acids and nucleic acids may also be used as energy sources; however, they are less abundant than sugars in the environment. Catabolism of sugars provides cells with energy when microorganisms grow in aerobic or anaerobic environments. Most heterotrophs have the enzymatic capability of utilizing glucose because glucose is the major chemical in cell walls of plants and, therefore, is the most abundant sugar on Earth. Cells of bacteria and archaea have rigid cell walls that prevent sugar polymers or other biopolymers from being transported into the cell. Extracellular enzymes degrade polymeric structures into small molecules that readily traverse the cell wall and are taken up by specific transporter systems. Prokaryotes can successfully compete against yeast and fungi for sugars in the environment because the active transport processes of the bacteria are highly efficient.

**Glycolysis.** The catabolism of glucose in many bacteria and archaea involves a series of related enzyme reactions making up the glycolytic pathway (see Figure 3.23). The function of glycolysis is generation of ATP, reducing power by the formation of NADH, and



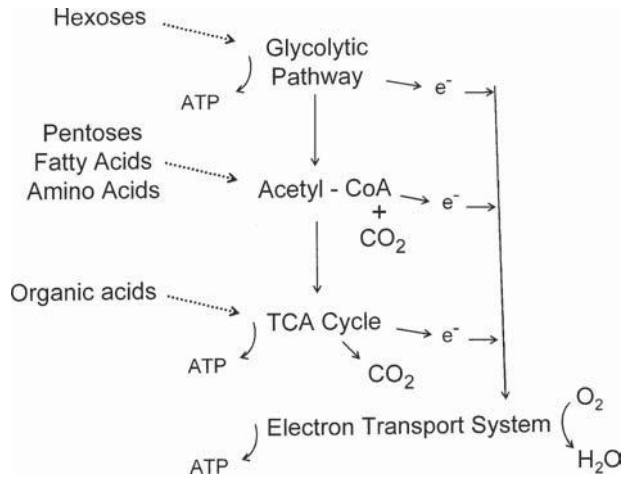
**Figure 3.23.** Metabolic pathways: (A) multienzyme steps convert glucose to pyruvate (glycolysis) with oxidation of the 2C compound (acetyl) to  $\text{CO}_2$ ; (B) ethanol fermentation. Conversion of glucose by glycolysis to pyruvate with subsequent production of ethanol and  $\text{CO}_2$ .

pyruvate is used for other metabolic systems. If the microorganism is growing aerobically, the electrons from NADH are passed by way of cytochromes to molecular oxygen with the coupled formation of ATP. If the microorganism is growing under anaerobic conditions, the electrons from NADH are diverted to an organic molecule without the formation of additional ATP. The readily identified reactions of substrate-level phosphorylation occur when phosphate is transferred from an organophosphate molecule to ADP with the production of ATP. The reactions resulting in ATP formation in glycolysis are examples of substrate-level phosphorylation.

**TCA Cycle.** The tricarboxylic acid (TCA) cycle (also known as the Krebs cycle), also called the Krebs cycle, functions in aerobic cells for the complete oxidation of numerous organic acids to carbon dioxide. As shown in Figure 3.23, pyruvate from glycolysis is converted to acetyl-CoA by a decarboxylation reaction.

Acetyl-CoA enters the TCA cycle by condensing with oxalacetate to produce citrate. In addition to decarboxylation reactions, several oxidative steps occur with the formation of NADH. Electrons from NADH are diverted to the aerobic electron transport system, where ATP is formed by oxidative phosphorylation. There is an interesting reaction where ATP is formed by substrate-level phosphorylation in the TCA cycle at the step where succinyl-CoA is converted to succinate. While a phosphorylated carbon compound is not present in formation of substrate-level phosphorylation, succinyl-CoA is a high-energy compound with enough energy to catalyze the formation of ATP from  $\text{ADP}^+$  inorganic phosphate.

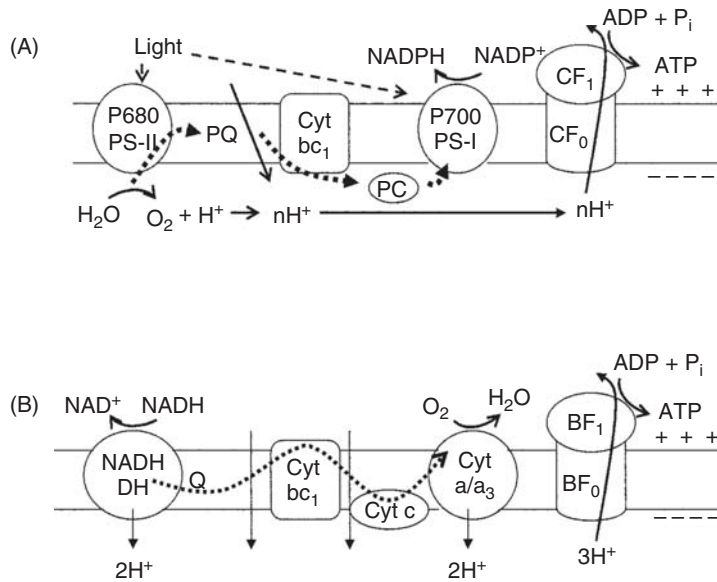
The TCA cycle not only uses acetyl-CoA derived from glucolysis but also oxidizes organic acids secreted from plant roots and utilizes breakdown products of amino acids, fatty acids, and nucleic acids. Thus, many organic compounds from the environment are shunted into the TCA cycle (Figure 3.24), which is an invaluable process for providing ATP by substrate-level phosphorylation and ATP as electrons are transferred from NADH to molecular oxygen. Because the TCA cycle functions only in aerobic conditions, anaerobic microorganisms have developed some alternate pathways for utilizing organic acids and sugars as energy sources.



**Figure 3.24.** Connection of metabolic pathways in microorganisms accounting for oxidation of various organic compounds.

**Fermentation.** Under anaerobic conditions, many bacteria and archaea utilize compounds from metabolism as the electron acceptor and not externally supplied gases or minerals. There is a necessity for the anaerobic microorganisms to reoxidize NADH; this is often accomplished by using products from the glycolytic pathway as the electron acceptor. Lactobacilli and oral streptococci use pyruvate as the electron acceptor with the production of lactate as the only end product of fermentation. Yeast and a few bacteria produce CO<sub>2</sub> and ethanol as fermentation products with acetaldehyde as the electron acceptor. Many bacteria, including *Escherichia coli*, have a diversity of organic acids as end products, and this mixed-acid fermentation is a result of oxidation of NADH by products from pyruvate metabolism. Clostridia and related anaerobes produce butyrate and solvents as end products, and the carbon compounds that accept electrons are also a result of pyruvate metabolism. Since no substrate phosphorylation is associated with fermentation, the principal function of fermentation is to reoxidize the electron carriers in the cytoplasm.

**Electron Transport.** Many bacteria and archaea couple the oxidation of electron carriers (e.g., NAD and cytochromes) to elements or compounds present in the environment. There is considerable similarity in the electron transport system of photosynthetic and nonphotosynthetic bacteria (Figure 3.25). Aerobic respiration with the use of O<sub>2</sub> as the electron acceptor is characteristic of eukaryotic metabolism as well as with prokaryotes; however, many electron donors are used specifically by the prokaryotes (Table 3.8). A unique metabolic process used by prokaryotes is the use of H<sub>2</sub> as the electron donor, and when coupled to appropriate electron acceptors, bacteria can use energy released from the reactions for growth (Table 3.9). A sizable number of bacterial species are capable of coupling growth to the reduction of nitrate to nitrite or even to N<sub>2</sub>. In addition to nitrate, prokaryotes may use sulfate, fumarate, Fe<sup>3+</sup>, Mn<sup>4+</sup>, S<sup>0</sup>, and several other inorganic compounds as the electron acceptor. Several respiratory systems are discussed in the following section.



**Figure 3.25.** Systems for electron transport and coupled ATP synthesis in bacteria: (top illustration) photosynthetic membrane indicating photodriven proton pump and generation of NADPH; (bottom illustration) aerobic electron transport in plasma membrane of bacteria showing proton export pumps and  $O_2$  as the final electron acceptor.

**TABLE 3.8.** Energy Yield of Reactions with Molecular Oxygen as Electron Acceptor and C1 or Inorganic Compounds as Electron Donors

Physiological Group	Oxidation–Reduction Reaction	Energy Yield/Reaction (kJ)
Methane oxidizers	$CH_4 + O_2 \rightarrow 2 H_2O + CO_2$	-783
Nitrite oxidizers	$NO_2^- + 0.5O_2 \rightarrow NO_3^-$	-73
Ammonia oxidizers	$NH^+ + 2 O_2 \rightarrow NO_2^- + 2H^+ + H_2O$	-267
Iron oxidizers	$Fe^{2+} + 0.25O_2 + H^+ \rightarrow Fe^{3+} + 0.25H_2O$	-44
Sulfur oxidizers	$S^0 + 1.5O_2 + H_2O \rightarrow SO_4^{2-} + 2H^+$	-581
Carboxidobacteria	$CO + 0.5O_2 \rightarrow CO_2$	-253

### 3.9.2 Chemolithotrophs

Microbial systems are dependent on an electron flow to energize plasma membranes for flagellar motility, uptake of nutrients, and generation of ATP. The electron flow proceeds from an electron donor to an electron acceptor, and microorganisms interface with the redox reactions to couple physiological activities, including cellular growth to the flow of electrons. Some bacteria obtain energy from the flow of electrons from molecular hydrogen ( $H_2$ ) to molecular oxygen ( $O_2$ ). This overall reaction is as follows:

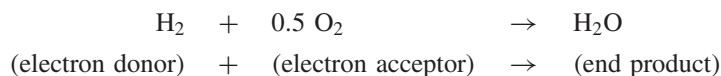
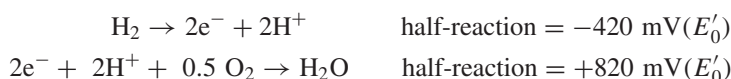


TABLE 3.9. Energy Yield of Reactions with Molecular Hydrogen as Electron Donor Contributing to Growth of Chemolithotrophic Bacteria and Archaea

Physiological Group	Oxidation–Reduction Reaction	Energy Yield/Reaction (kJ)
Ammonia producers	$3\text{H}_2 + \text{NO}_2^- + 2\text{H}^+ \rightarrow \text{NH}_4^+ + 2 \text{H}_2\text{O}$	–437
Hydrogen oxidizers	$\text{H}_2 + 0.5\text{O}_2 \rightarrow \text{H}_2\text{O}$	–233
Sulfate reducers	$4\text{H}_2 + \text{SO}_4^{2-} \rightarrow \text{HS}^- + 3\text{H}_2\text{O} + \text{OH}^-$	–152
Methanogens	$4\text{H}_2 + \text{CO}_2 \rightarrow \text{CH}_4 + 2\text{H}_2\text{O}$	–136
Acetogens	$4\text{H}_2 + 2\text{CO}_2 \rightarrow \text{acetic acid} + 2\text{H}_2\text{O}$	–105
Fumarate reducers	$\text{H}_2 + \text{fumarate} \rightarrow \text{succinate}$	–86
Sulfur reducers	$\text{H}_2 + \text{S}^0 \rightarrow \text{HS}^- + \text{H}^+$	–29

This reaction is a summation of two separate reactions:



In biological systems, various carriers are used to transfer electrons from  $\text{H}_2$  oxidation to  $\text{O}_2$  reduction. Bacteria and archaea can use many different electron donors and electron acceptors (see Table 3.10). For an appropriate electron donor–acceptor combination to support growth, several conditions must be met. Generally the half-reaction of the electron donor is more negative than the half-reaction of the electron acceptor, so the flow of electrons is from electronegative to electropositive. The difference of the half-reactions should exceed 200 mV to provide sufficient energy for ATP synthesis. Finally, the bacteria or archaea must have the appropriate enzymes for oxidation and reduction of the substrates and have the necessary cytochromes or other relevant electron carriers. Microorganisms that use inorganic compounds or minerals as either electron donor or electron acceptor are called *chemolithotrophs*, and if the carbon source is  $\text{CO}_2$ , the microorganisms are known as *chemoautotrophs*.

In terms of the electron donor or acceptor, microorganisms are assigned to different physiological groups or guilds (see Table 3.11). It must be emphasized that bacteria and archaea, unlike higher plants and animals, can grow anaerobically using electron acceptors other than  $\text{O}_2$ . The half reaction of the electron acceptor couple determines the environment where bacteria can grow. As indicated in Figure 3.26, an electron acceptor

TABLE 3.10. Midpoint Potentials for Different Electron Donors and Acceptors

Couple Donor/Product	Potential (mV)	Couple Acceptor/Product	Potential (mV)
Pyruvate/ $\text{CO}_2$ + acetyl-CoA	–610	$\text{S}^0/\text{HS}^{2-}$	–279
Formate/ $\text{CO}_2$	–432	Fumarate/succinate	+33
$\text{H}_2/\text{H}^+$ (1 atm $\text{H}_2$ )	–410	$\text{Fe}^{3+}/\text{Fe}^{2+}$ (pH 7)	+200
NADH/ $\text{NAD}^+$	–320	$\text{ASO}_4^{2-}/\text{ASO}_3^{2-}$	+220
Acetate/ $\text{CO}_2$	–240	$\text{UO}_2^{2-}/\text{UO}_2 \downarrow$	+227
Lactate/pyruvate	–190	$\text{MnO}_2/\text{Mn}^{2+}$	+410
		$\text{NO}_3^-/\text{NO}_2^-$	+425
		$\text{CrO}_4^{2-}/\text{Cr}^{3+}$	+552
		$\text{Fe}^{3+}/\text{Fe}^{2+}$ (pH 2)	+771
		$\text{O}_2/\text{H}_2\text{O}$ (1 atm $\text{O}_2$ )	+815

TABLE 3.11. Microbial Guilds Based on Metabolic Characteristics of Electron Donor or Acceptor

Guild or Physiological	Electron Donor	Electron Acceptor	Examples Group
Sulfate reducers	Lactate, H <sub>2</sub>	Sulfate	<i>Desulfovibrio, Desulfotomaculum</i>
Nitrate reducers	Succinate	Nitrate	<i>Pseudomonas</i>
Iron reducers	Lactate	Fe <sup>3+</sup>	<i>Shewanella, Geobacter</i>
Manganese oxidizers	Mn <sup>2+</sup>	O <sub>2</sub>	<i>Arthrobacter, Hyphomicrobium</i>
Iron oxidizers	Fe <sup>2+</sup>	NO <sub>3</sub> <sup>-</sup> , O <sub>2</sub>	<i>Gallionella, Leptothrix</i>

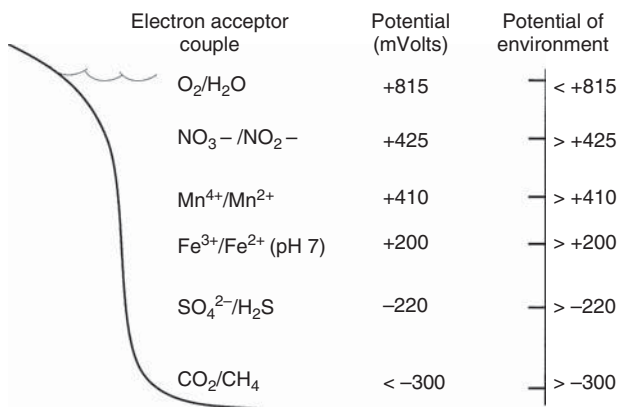


Figure 3.26. In an environment with a changing oxidation–reduction profile, the oxidation potential of the environment selects the type of electron acceptor used by microorganisms.

TABLE 3.12. Distribution of Chlorophylls in Microorganisms

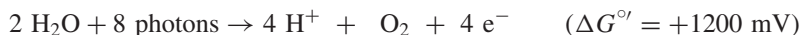
Organism	Chlorophyll				Bacteriochlorophyll					
	a	b	c	d	a	b	c	d	e	g
Higher plants	+	+	-	-						
Green algae	+	+	-	-						
Diatoms	+	-	+	-						
Brown algae	+	-	+	-						
Red algae	+	-	-	+						
Cyanobacteria	+	-	-	+						
Purple sulfur bacteria					+	or	+	-	-	-
Purple nonsulfur bacteria					+	or	+	-	-	-
Green bacteria					+		-	±	±	±
Heliobacteria					-		-	-	-	+

with a highly negative electron acceptor is readily inhibited if the environment is not sufficiently electronegative. Thus, physical and chemical parameters of an environment are critical in selecting the types of microorganisms present.



### 3.9.3 Photophosphorylation

While higher plants have a highly conserved photosynthetic system, considerable diversity exists in the photosynthetic activities of bacteria (Table 3.12). The cyanobacteria have an aerobic photosynthetic system markedly similar to that of green algae and higher plants. Energetics of the photolysis of water is indicated as follows:

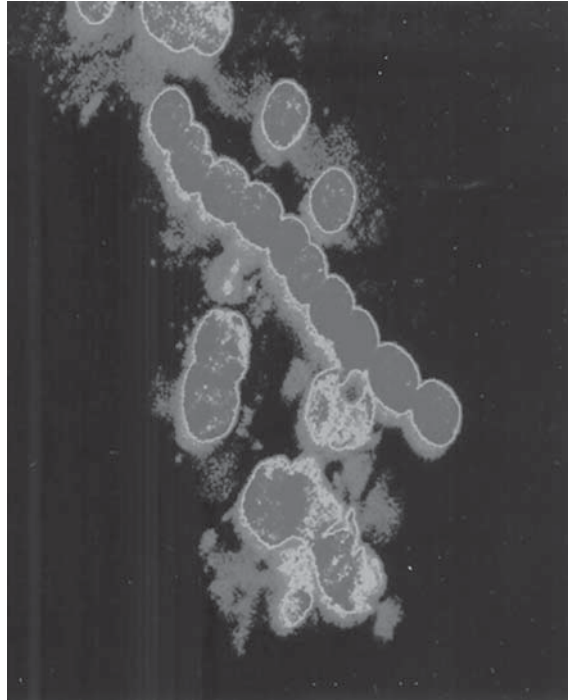


In cyanobacterial photosynthesis, the electron donor is water with the release of  $\text{O}_2$ . Unlike green algae and higher plants, cyanobacteria and red algae have phycobilins which are light receptors in addition to chlorophyll. These light receptors are phycoerythrin and phycocyanin, which are collectively positioned in phycobilisome structures. The function of these ancillary light receptors is to collect light from a spectrum broader than that acquired by chlorophyll, and this capability of broad harvesting of light is extremely important in aquatic environments. The ancillary photosynthetic pigments in *Anabaena* fluoresce red (Figure 3.27) on exposure to ultraviolet light.

Additionally, some anaerobic bacteria have photosynthetic systems that utilize sulfur compounds or organic acids as electron donors without the production of  $\text{O}_2$ . Anaerobic photosynthetic systems have bacteriochlorophyll, which is a structural modification of chlorophyll A, and there are different types of bacteriochlorophylls, which vary according to chlorophyll structure. Associated with each chlorophyll structure is a specific wavelength for light absorption, which enables bacteria to use light that penetrates into the water column. The wavelengths for absorption by different photosynthetic components are given in Table 3.13. The ecological significance of these various pigments is that each photosynthetic group is capable of obtaining energy for different parts of the light spectrum and to grow at different levels in aquatic systems. A model indicating location of photosynthetic growth reflecting differences in light absorption in a water column is shown in Figure 3.28.

### 3.9.4 Bacteriorhodopsin Reaction

**Bacteriorhodopsin.** Many of the marine bacteria and archaea have photodriven ion pumps in the plasma membrane, and these light driven responses do not require chlorophyll. *Halobacterium salinarum*, an archaea, produces a special protein in the plasma membrane known as *bacteriorhodopsin*, and this purple protein pumps protons out of the cytoplasm when energized by light. Bacteriorhodopsin has a structure similar to that of rhodopsin, the protein associated with vision in animals. The bacteriorhodopsin absorbs light at 570 nm and uses this energy to translocate protons from the cytoplasm across the plasma membrane to generate a protonmotive force on the plasma membrane. Protons on the exterior of the plasma membrane can generate ATP or export  $\text{Na}^+$  from the cytoplasm by the  $\text{H}^+/\text{Na}^+$  antepporter system. A model indicating this activity is given in Figure 3.29. Additionally,  $\text{K}^+$  uptake can be driven by membrane charge, and the intracellular concentration of  $\text{K}^+$  is used to assist in maintaining cellular osmotic balance. The activity of proton-driven export by bacteriorhodopsin enables *H. salinarum* to maintain viability without metabolism and promotes slow cell growth. While bacteriorhodopsin is characteristic of archaea, bacteria in marine environments have a similar protein that can be energized by light to export protons.



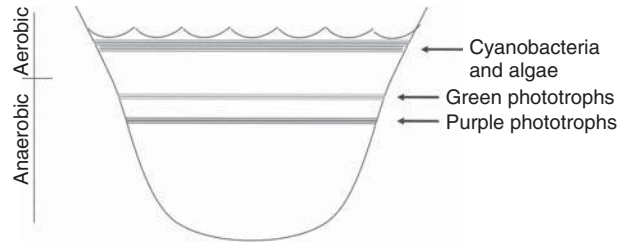
**Figure 3.27.** *Anabaena flosaqua* viewed by fluorescence microscopy. Cells appear red, due to UV light absorbed by the phycobiliproteins of the cyanobacteria; capsular material outside of the cell appears green.

**TABLE 3.13.** Distribution of Chlorophylls in Microbial Cells and Wavelengths for Maximal Absorption

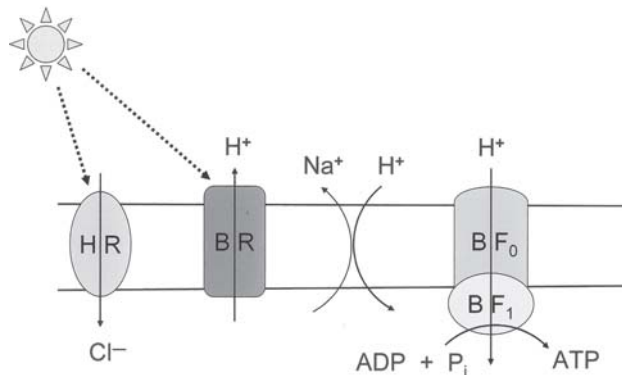
Microorganism	Chlorophyll	Absorption Peak (nm) <sup>a</sup>
Cyanobacteria	Chlorophyll <i>a</i>	680–685
Green bacteria	Bacteriochlorophyll <i>a</i>	805–810
Purple bacteria	Bacteriochlorophyll <i>a</i>	850–910
Purple bacteria	Bacteriochlorophyll <i>b</i>	1020–1035
Green bacteria	Bacteriochlorophyll <i>c</i>	750–755
Green bacteria	Bacteriochlorophyll <i>d</i>	725–735
Green bacteria	Bacteriochlorophyll <i>e</i>	715–725
Helicobacteria	Bacteriochlorophyll <i>g</i>	788

<sup>a</sup>Chlorophylls extracted from cells and dissolved in acetone have an absorption that is less than chlorophyll in whole cells.

**Halorhodopsin.** Contained in the plasma membrane of *H. salinarum* is a light-activated protein, halorhodopsin, which is responsible for the specific importing of chloride ion. This uptake of  $\text{Cl}^-$  assists the cell in stabilizing the osmotic imbalance due to the presence of NaCl in the marine environment. Additional sensory and chemotactic rhodopsins are present in bacteria to promote cellular movement to light for optimal



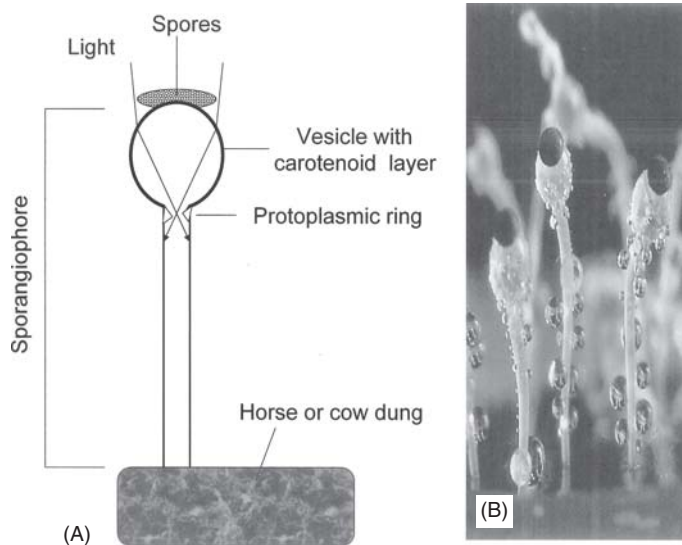
**Figure 3.28.** Model showing layers of photosynthetic microorganisms in a deep lake, based on the penetration of light and anaerobic condition in the water column. See insert for color representation.



**Figure 3.29.** Flowchart depiction of photosensitive pumps in plasma membrane of halophiles: HR = halorhodopsin, a chloride importer; BR = bacteriorhodopsin, a proton exporter;  $BF_0 + BF_1$  = subunits of the proton-driven ATP synthase. See insert for color representation.

benefit. Bacterioruberins are found in some bacteria, and these C50 carotenoids serve as ancillary antennas for the light-driven ion pumps.

**Carotenoids of Fungi.** A coprophilic fungus, *Pilobus* (“hat thrower,” Greek), produces asexual spores on an aerial sporangiophore and forcibly hurls the spores toward a light source. The fungus grown on waste material from horses, cows, and various other herbivores within a day will produce a fruiting structure as shown in Figure 3.30. A vesicle at the tip of the 1-cm sporangiophore is lined with carotenoids and serves as a sensory system to orient the sporangiophore toward light. On striking the carotenoid-rich protoplasm, the light is refracted toward the protoplasmic ring at the base of the vesicle by the protoplasm functioning as a biconcave lens. If light strikes the wall of the vesicle, growth of the sporangiospore adjusts so that light entering the protoplasmic ring is symmetric with the sporangiophore oriented toward the light. As the turgor pressure inside the vesicle increases, the spores are released and hurled several feet away from the site of the sporangium. Spores that settle on foliage will be consumed by grazing animals, and these spores will pass through the animal unharmed. Germination of the spores and growth of the fungus is supported by the animal waste rich in nutrients. In an interesting opportunistic adaptation, the larval lungworm nematodes released from infected cows, deer, or horses will move up the sporangiophores and be thrown into the vegetations along with the spores of *Pilobus*. As an animal consumes infected grass, the

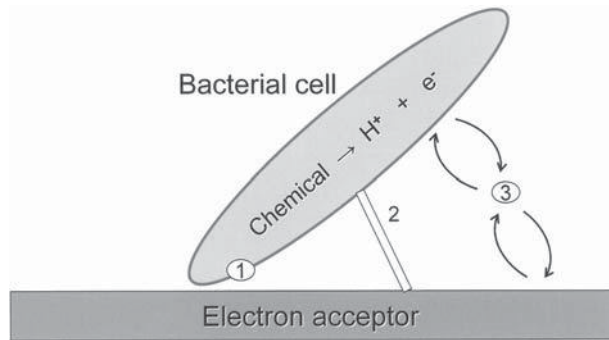


**Figure 3.30.** Aerial structures of *Pilobus crystallinus* producing asexual spores (A); model indicating the “lens system” used to orientate sporangiophore toward the light (B). (Photograph of *P. crystallinus* from *Ward’s Natural Science* used with permission).

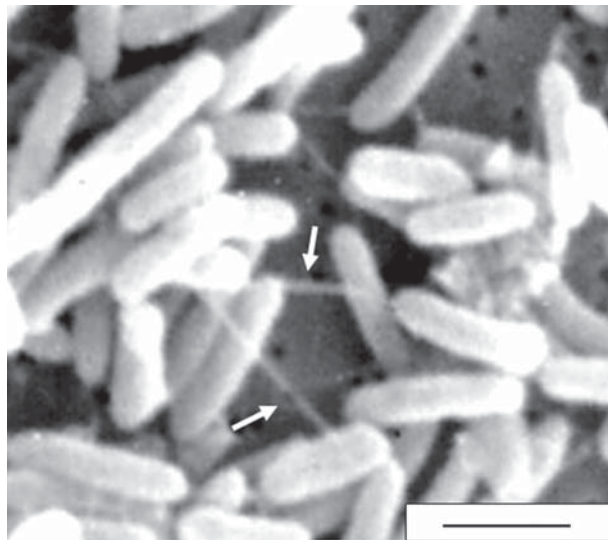
parasitic nematode is ingested and the lifecycle of the parasite is complete with *Pilobus* functioning as an important vector (Foos 1997).

### 3.10 BIOELECTROCHEMICAL ACTIVITIES

In 1911, M. C. Porter proposed the concept that microbial metabolism produced an electric current that was potentially of economic importance. Since then, various studies have examined attempts to enhance the magnitude of the electric current of microbial fuel cells, and more recent studies have provided basic information on ecological features of the bioelectrochemical process (Lovley and Nevin 2008; Rabaey et al. 2007). Electrons required to produce the current are derived from the half-cell reaction involving the bacterial cell (see Figure 3.31). The electrons move from the cell to a mineral, another cell, or other electron acceptor in the environment. The extracellular transfer of electrons is interesting and is proposed to occur by at least three avenues. In the case of *Shewanella* and *Geobacter*, *c*-type cytochromes in the outer membrane of these Gram-negative cells may transfer electrons from cellular metabolism to insoluble  $\text{Fe}^{3+}$  oxides. Electrically conductive pilus-like structures, called *nanowires*, are used by *Geobacter sulfurreducens* and *Shewanella oneidensis* MR1 when grown on ferrihydrite as the electron acceptor. The use of nanowires for bridging between cells of different species has been proposed for electron transfer between *Pelotomaculum thermopropionicum*, a propionate fermenter, and *Methanothermobacter thermautotrophicus*, a methane producer (Aelterman et al. 2008). Another mechanism for transferring electrons from the bacterial cell to environmental electron acceptors is through the use of chemical mediators or redox shuttles. The chemical mediator would be reduced by the bacterial cell, diffuse through the biofilm, and



**Figure 3.31.** Mechanisms for extracellular electron transfer by bacteria: (1) cytochrome or hydrogenase at the surface of the bacterial outer membranes; (2) nanowires as either single or intertwined wires; (3) soluble shuttle molecules that can carry electrons.



**Figure 3.32.** Electron micrograph showing nanowires between bacterial cells (photograph provided by Larry Barton).

transfer electrons to an appropriate electron acceptor, and the oxidized chemical would diffuse back to the cell to acquire additional electrons. Humic acids, riboflavin (Marsili et al. 2008), redox-active dyes, and perhaps even H<sub>2</sub> have been used as electron shuttle compounds. While nanowires (see Figure 3.32) and outer membranes are associated with Gram-negative bacteria, environmentally significant Gram-positive organisms could use electron shuttle compounds for extracellular electron movement. These different mechanisms for extracellular electron transfer would indicate the influence of bacteria on their environment. Direct contact is required for electron movement with cytochromes or proteins in the outer membrane of the cells. A single nanowire would transfer electrons up to a distance of 20 μm, while bundles of intertwined nanowires could transfer electrons up to 50 μm.

### 3.11 SUMMARY

Microorganisms are highly diverse in terms of structure and form, which enable them to grow in different environments. Prokaryotes are usually smaller in size than eukaryotes, and this permits prokaryotes to acquire nutrients in a region where they are sheltered from larger microorganisms. Within a microbial species there is some size variation; rapidly growing cells are larger than the more slowly growing cells, and some cells shrink in size as a result of starvation. Nanosized bacteria or archaea are found in close association with another living cell because these nanocells have insufficient genetic information for independent growth. A few species of bacteria have a large size to accommodate unique developmental or metabolic processes. The presence of pili on Gram-negative bacteria and stalks on *Caulobacter* enables these microorganisms to become immobilized in an environment where growth is optimum. Although intracellular organization in prokaryotes is not as developed as with eukaryotes, several prokaryotes have intracellular granules consisting of nutrient reserves or aggregates of biochemical activity as seen with carboxysomes and magnetosomes. Generally internal membranes are continuous with the plasma membrane and serve to increase the surface-to-volume ratio of specific bacteria for oxidization of gases (e.g., methane, ammonia) or conversion of light energy to ATP by photosynthetic processes.

Prokaryotes have developed responses to transient chemical changes in the environment. Many bacteria are able to persist in the environment when nutrients are lacking by production of resistive cysts or endospores. Flagella function as organelles to position cells in the aquatic environment for best growth potential. Movement by prokaryotes on solid surfaces is attributed to a directed gliding activity, and spirochete bacteria move through gelatinous matrix by their unique endoflagellar activity. Both production of resistive structures and chemotactic movement by prokaryotes are influenced by highly effective sensory systems, located, in part, in the plasma membrane for the communication between the cytoplasm and the extracellular environment. Additional sensory systems respond to a large number of chemical and physical stimuli in the environment and regulate gene expression by the production of special sigma factors that regulate the reading of several genes not normally expressed. Through the use of this global regulation system, a single stimulus such as heatshock or nutrient stress can account for the expression of many genes.

While all biological systems use similar biosynthetic systems energized by ATP, and ATP production originates from respiratory processes, prokaryotes are distinguished by having a highly diverse electron transport system. In addition to having a carbohydrate-based catabolism, chemolithotrophic prokaryotes use inorganic compounds or minerals as electron donors. Also, some prokaryotic microorganisms have anaerobic respiration where inorganic compounds are used as electron acceptors instead of  $O_2$ . Even though these chemolithotrophic prokaryotes have cytochromes and other electron transport molecules that may differ from those found in mitochondrial systems, the charging of the plasma membrane with proton export is coupled to unidirectional electron transport. In photosynthesis, the mechanism for photophosphorylation is similar to that for oxidative phosphorylation in aerobic respiration in heterotrophic aerobes and chemolithotrophic aerobes or anaerobes. There are several different types of bacterial photosynthesis, where the electron donor may be water, sulfide, or small organic acids. Aerobic photosynthesis occurs when water is the electron donor because  $O_2$  is released as electrons and protons are extracted from water. Several examples of anaerobic photosynthesis occur in

bacteria where water is not generated, and these anaerobic bacteria use bacteriochlorophylls, which are structural modifications of chlorophyll present in oxygenic photosynthetic systems. Thus, the extreme variability in electron donors and electron acceptors for microbial metabolism enable them to grow in every environment found on Earth.

### 3.12 DELVING DEEPER: CRITICAL THINKING QUESTIONS

1. What selective pressures would account for evolutionary development of nanobacteria and for large microorganisms?
2. What mechanisms contribute to bacterial movement?
3. Explain how global regulation contributes to successful dominance of a bacterial species in the environment.
4. Synthesis of the bacterial endospore requires more biosynthetic energy than does production of bacterial cysts. What environmental pressures could have been responsible for selection of cells producing the bacterial endospore?
5. What is the benefit for photosynthetic microorganisms having different types of pigments for absorption of light?
6. Compare oxidative phosphorylation processes in chemolithotrophic and heterotrophic bacteria. What are the differences and what are the similarities of energy production in chemolithotrophic and heterotrophic bacteria?
7. Distinguish between anaerobic respiration and fermentation in microorganisms.

### BIBLIOGRAPHIC MATERIAL

#### Suggested Reading

- Blair DF (1995), How bacteria sense and swim, *Annu. Rev. Microbiol.* **49**:489–522.
- Boyd ES, Leavitt WD, Geesey GG (2009), CO<sub>2</sub> uptake and fixation by a thermoacidophilic microbial community attached to precipitated sulfur in a geothermal spring, *Appl. Environ. Microbiol.* **75**:2464–2475.
- DeRosier DJ (1998), The turn of the screw. The bacterial flagellar motor, *Cell* **93**:17–20.
- Gerday C, Glansdorff N (2007), *Physiology and Biochemistry of Extremophiles*, Washington, DC: ASM Press.
- Mattick JS (2002), Type IV pili and twitching motility, *Annu. Rev. Microbiol.* **56**:289–314.
- McBride MJ (2003), Bacterial gliding motility: Multiple mechanisms for cell movement, *Nature Rev. Microbiol.* **8**:15–25.
- Michiels C, Bartlett DH, Aertsen A (2008), *High-Pressure Microbiology*, Washington, DC: ASM Press.
- Nicholson L, Murakata, Horneck G, Melosh HJ, Setlow P (2000), Resistance of *Bacillus* endospore to extreme terrestrial and extraterrestrial environments, *Microbiol. Molec. Biol. Rev.* **64**:548–572.
- Sleytr B, Beveridge TJ (1999), Bacterial S-layers, *Trends Microbiol.* **7**:253–260.
- Spormann AM (1999), Gliding motility in bacteria: Insights from studies of *Myxococcus xanthus*, *Microbiol. Molec. Biol. Rev.* **63**:621–641.
- Whitworth DE (2007), *Myxobacteria: Multicellularity and Differentiation*, Washington, DC: ASM Press.



Young KD (2007), Bacterial morphology: Why have different shapes? *Curr. Opin. Microbiol.* **10**:596–600.

### Cited References

- Aelterman P, Rabaey K, De Schamphelaire L, Clauwaert P, Boon N, Verstraete W (2008), Microbial fuel cells as an engineered ecosystem, in Wall JD, Harwood CS, Demain A, eds., *Bioenergy*, Washington, DC: American Society for Microbiology, pp. 307–320.
- Baker BJ, Tyson GW, Webb RI, Flanagan J, Hugenholtz P, Allen P, Allen EE, Banfield JF (2006), Lineages of acidophilic archaea revealed by community genomic analysis, *Science* **314**:1933–1935.
- Bakken LR, Olsen RA (1987), The relationship between size and viability of soil bacteria, *Microbial Ecol.* **21**:789–793.
- Barton LL (2005), *Structural and Functional Relationships in Prokaryotes*, New York: Springer.
- Bazylnski DA, Schübbe S (2007), Controlled biomineralization by and applications of magnetotactic bacteria, *Adv. Appl. Microbiol.* **62**:21–62.
- Ben-Jacob E, Cohen I, Gutnick DL (1998), Cooperative organization of bacterial colonies: From genotype to morphotype, *Annu. Rev. Microbiol.* **52**:779–806.
- Cossart P, Boquet P, Normark S, Rappuoli R (2000), *Cellular Microorganisms*, Washington, DC: ASM Press.
- Faivre D, Schüler D (2008), *Magnetotactic Bacteria and Magnetosomes*, *Chemical Review ASAP Article*, 10.1021/cr078258w, Web release date: Oct. 15, 2008.
- Ferguson BA, Dreisbach TA, Parks CG, Filip GM, Schmitt CL (2003), Coarse-scale population structure of pathogenic *Armillaria* species in a mixed-conifer forest in the Blue Mountains of northeast Oregon, *Can. J. Forest Res.* **33**:612–623.
- Folk RL, Taylor LA (2002), Nannobacterial alteration of pyroxenes in Martian meteorite Allan Hills 84001, *Meteor. Planet. Sci.* **37**:1057–1069.
- Foos KM (1997), *Pilobus* and lungworm disease affecting elk in Yellowstone National Park, *Mycol. Res.* **101**:1535–1536.
- Godoy F, Vancanneyt M, Martinez M, Steinbuchel A, Swings J, Rehm BHA (2003), *Sphingopyxis chilensis* sp. nov., a chlorophenol degrading bacterium that accumulates polyhydroxyalkanoate and transfer to *Sphingomonas alaskensis* to *Sphingopyxis alaskensis* comb. nov., *Int. J. Syst. Evolut. Microbiol.* **53**:473–477.
- Hahn MW, Lunsdorf H, Wu Q, Schauer M, Hofle MG, Boenigk J, Stadler P (2003), Isolation of novel ultramicrobacteria classified as *Actinobacteria* from five freshwater habitats in Europe and Asia, *Appl. Environ. Microbiol.* **69**:1442–1451.
- Hoch HA, Silhavy TJ, eds. (1994), *Two-Component Signal Transduction*, Washington, DC: American Society for Microbiology Press.
- Huber H, Burggraf S, Mayer T, Wyschkony I, Rachel R, Stetter K (2000), *Ignococcus* gen. nov., a novel genus of hyperthermophilic, chemolithotrophic Archaea, represented by two new species, *Ignococcus islandicus* sp. nov. and *Ignococcus pacificus* sp. nov., *Int. J. Syst. Evolut. Microbiol.* **50**:2093–2100.
- Janssen P, Schuhmann A, Morschel E, Rainey F (1997), Novel anaerobic ultramicrobacteria belonging to the verrucomicrobiales lineage of bacterial descent isolated by dilution culture from anoxic rice paddy soil, *Appl. Environ. Microbiol.* **63**:1382–1388.
- Koch AL (1996), What size should a bacterium be? A question of scale, *Annu. Rev. Microbiol.* **50**:317–348.
- Koch AL (1989), The variability and individuality of the bacterium, in: *Escherichia coli and Salmonella typhimurium: Cellular and Molecular Biology*, Ingraham JL, Brooks Low K,

- Magasanik BM, Schaechter S, Umbarger HE, eds., Washington, DC: American Society for Microbiology, pp. 1606–1614.
- Loveland-Curtze J, Miteva VI, Brenchley JE (2009), *Herminiimonas glaciei* sp. nov. a novel ultramicrobacterium from 3042m deep Greenland glacial ice, *Int. J. Syst. Evolut. Microbiol.* **59**:1272–1277.
- Lovley DR, Nevin KP (2008), Electricity production with electricigens, in Wall JD, Harwood CS, Demain A, eds., *Bioenergy*, Washington, DC: American Society for Microbiology, pp. 295–307.
- Marsili E, Baron DB, Shikhare ID, Coursolle D, Gralnick JA, Bond DR (2008), *Shewanella* secretes flavins that mediate extracellular electron transfer, *Proc. Natl. Acad. Sci. (USA)* **105**:3968–3973.
- Martel J, Ding E, Young J (2008), Purported nanobacteria in human blood as calcium carbonate nanoparticles, *Proc. Natl. Acad. Sci. (USA)*, **105**:5549–5554.
- Matz MV, Frank TM, Marshall NJ, Widder EA, Johnsen S (2008), Giant deep-sea protest produces a bilaterian-like traces, *Curr. Biol.* **18**:1849–1854.
- Morita RY (1997), *Bacteria in Oligotrophic Environments. Starvation-Survival Lifestyle*, New York: Chapman & Hall.
- Nakabachi A, Yamashita A, Toh H, Ishikawa H, Dunbar H, Moran N, Hattori M (2006), The 160-kilobase genome of the bacterial endosymbiont Carsonella, *Science* **314**: 267.
- Oelze J, Drews G (1981), Membranes of phototrophic bacteria, in Ghosh BK, ed., *Organization of Prokaryotic Cell Membranes*, Vol. II, Boca Raton, FL: CRC Press, pp. 113–196.
- Panikov NS (2005), Contribution of nanosized bacteria to the total biomass and activity of a soil microbial community, *Adv. Appl. Microbiol.* **57**:245–296.
- Pérez-Brocail V, Gil R, Ramos S, Lamelas A, Postigo M, Michelena JM, Silva FJ, Moya A, Latorre A. 2006. A small microbial genome: the end of a long symbiotic relationship. *Sci.* **314**:259–260.
- Plamann L, Kaplan HB (1999), Cell-density sensing during early development in *Myxococcus xanthus*, in Dunny GM, Winans SC, eds., *Cell-Cell Signaling in Bacteria*, Washington, DC: American Society for Microbiology Press, pp. 67–82.
- Rabaey K, Rodríguez J, Blackall LL, Keller J, Gross P, Batstone D, Verstraete W, Nealon KH (2007), Microbial ecology meets electrochemistry: Electrical driven and driving communities, *Int. Soc. Microbiol. Ecol. J.* **1**:9–18.
- Rappé MS, Cannon SA, Vergin KL, Giovannoni SJ (2002), Cultivation of the ubiquitous SAR11 marine bacterioplankton clade, *Nature* **418**:630–633.
- Roszak DB, Colwell RR (1987), Survival strategies of bacteria in the natural environment, *Microbiol. Rev.* **51**:365–379.
- Schulz HN, Jørgensen BB (2001), Big bacteria, *Annu. Rev. Microbiol.* **55**:105–137.
- Shimkets JL, Kaiser D (1999), Cell contact-dependent C signaling in *Myxococcus xanthus*, in Dunny GM, Winans SC, eds., *Cell-Cell Signaling in Bacteria*, Washington, DC: American Society for Microbiology Press, pp. 83–100.
- Thao ML, Moran NA, Abbot P, Brennan EB, Burckhardt DH, Baumann P (2000), Cospeciation of psyllids and their primary prokaryotic endosymbionts, *Appl. Environ. Microbiol.* **66**:2898–2905.
- Urbano P, Urbano F (2007), Nanobacteria: Facts or fancies? *PLoS* **3**:567–570.
- Wainwright M (1999), Nanobacteria and associated elementary bodies in human disease and cancer, *Microbiology* **145**:2623–2624.
- Wu D, Daugherty SC, Van Aken SE, Pal GH, Walkins KL, Khouri H, Tallon LJ, Zaborsky JM, Dunbar HE, Tran PL, Moran NA, Eisen JA (2006), Metabolic complementarity and genomics of the dual bacterial symbiosis of sharpshooters, *PLoS Biol.* **4**:1079–1092.

---

# THE MICROBIAL HABITAT: AN ECOLOGICAL PERSPECTIVE

---

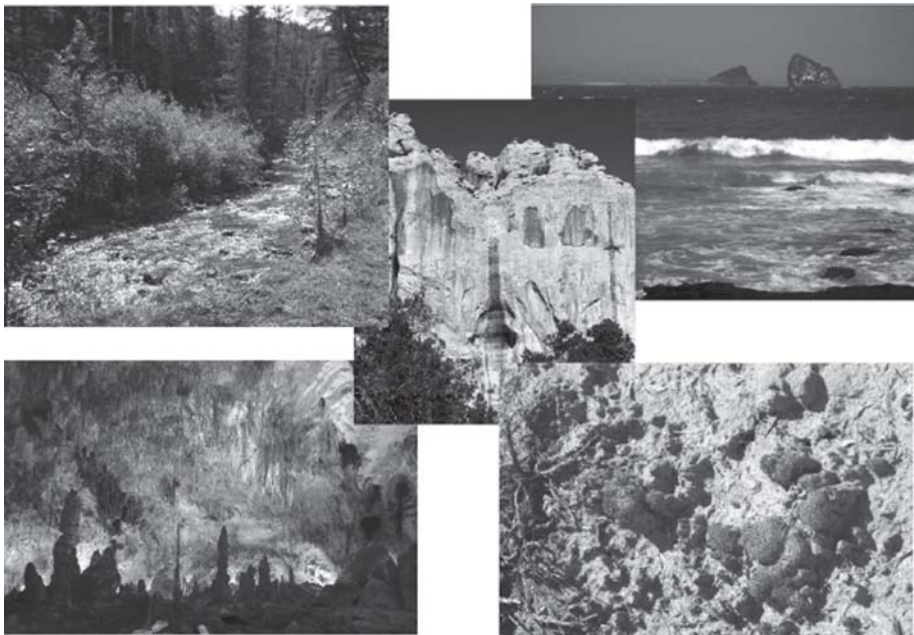
## 4.1 CENTRAL THEMES

- Within ecosystems, there are a variety of areas, called *habitats*, where particular microorganisms reside, which are characterized by a given set of chemical, physical, and biological conditions.
- Microorganisms occupy and adapt to niches within habitats in much the same way that animals and plants do, but their ability to acquire new metabolic functions through horizontal gene transfer can lead to dynamic niche boundaries.
- Major habitat types (aqueous, soil, rock, atmospheric, intracellular) differ in fairly substantial ways, which leads to differences in microbial composition.
- Habitats are composed of many microenvironments that differ in abiotic conditions, such as oxygen level, pH, temperature, moisture content, nutrient availability, and light.
- Some habitats within these categories are extreme in terms of pH, temperature, and ultraviolet radiation.
- Aquatic habitats are common with approximately 71% of Earth's surface being occupied by oceans, rivers, streams, and lakes. Key aquatic microbial players include phototrophs that generate primary productivity and heterotrophs that are key cyclers of carbon.

- Soil habitats are widespread and important microbial habitats, where nitrogen fixing and other microorganisms play key roles in plant nutrition.
- Rock habitats, such as rock surfaces and endolithic environments, offer niches for phototrophs and other microorganisms, while subsurface habitats such as caves and deep subsurface pore spaces within Earth's crust offer environments where organisms use molecular hydrogen, and reduced sulfur and iron species for energy.
- Many microbial species, including several pathogens, are transported over long distances through the atmospheric habitat, to colonize new habitats.
- Ecologically distinct populations, within genetically similar strains, can be identified within habitats.

## 4.2 HABITATS: AN OVERVIEW

It is very difficult for a human, who is on the order of 890,000 times bigger than an *E. coli* cell, to think in terms of microbial habitats, which are on the order of micrometers to millimeters in size. Over this span, conditions such as oxygen or pH can change dramatically. This creates microenvironments, and habitats are often quite patchy rather than uniform. Various abiotic factors affect microbial populations in these habitats (Figure 4.1) and help to create these microenvironments (Table 4.1). Note how these factors affect the different habitats that we will discuss in the next sections. Any disturbance (see Section 9.8.3) can lead to changes in microbial populations within habitats over time.



**Figure 4.1.** Aquatic and terrestrial habitats are varied; examples include the stream, ocean, rock, soil, and cave habitats pictured here (images courtesy of Kenneth Ingham and Peter Jones). See insert for color representation.

TABLE 4.1. Effects of Abiotic Factors Such as Temperature, Light, pH, Salinity, Moisture and Oxygen Availability on Growth of Microbial Populations Within Habitats

Abiotic Factor	Range of States
Oxygen level	Anoxic–microoxic–oxic
Salinity	Hypersaline–marine–freshwater
Moisture level	Arid–moist–wet
pH	Acidic–neutral–alkaline
Temperature	Hot–warm–cold
Light level	Aphotic–low level–bright–UV

Source: Modified from Madigan et al. (2009).

#### 4.2.1 The Niche

Within a habitat, the sum of the environmental factors that affect the ability of a species to live and reproduce, is called the “niche.” If you turn to the general ecological literature, you find that there is what is called the “fundamental niche,” which represents all the environmental factors. There is also the “realized niche,” which represents the actual niche when one takes into account biotic interactions (i.e., competition) that may limit a species’ growth and reproduction [reviewed in Molles (2008)]. The niche concept has been applied to microorganisms more recently, and Lawrence (2002) suggested that the acquisition of new genes through horizontal gene transfer may allow bacteria and archaea to exploit new niches that are not open to their parental lineages. This concept of the niche, as developed for bacteria and archaea by Lawrence (2002), focuses more on the organism’s acquisition of new functional capabilities through horizontal gene transfer, which suggests a more dynamic nature for niche boundaries. The niche where *Ferroplasma* (See Section 2.6.1) survives and reproduces most effectively is characterized by conditions that are acidic, stable, rich in ferrous iron and heavy metals, and moderate in temperatures. These conditions characterize the niche space for *Ferroplasma*. Species can also modify their environment, making the environment more or less habitable for other species (see Sections 9.7.2 and 9.4).

### 4.3 AQUATIC HABITATS

Aquatic habitats range from the vast ocean reaches to lakes and flowing bodies of water, such as rivers and streams. Roughly 71% of the Earth’s surface is occupied by water, >97% of which is contained in the world’s oceans. Less than 1% of water is found in streams, rivers, and lakes. Water in all these different aquatic habitats is constantly being renewed through the hydrologic cycle [see Molles (2008) for an overview]. The size and diversity of aquatic habitats hints at the importance of aquatic habitats for microorganisms. Major microbial players in aquatic habitats include phototrophs, which are critical to primary production, and heterotrophs, which participate in the cycling of carbon in aquatic habitats.

Environmental and physicochemical conditions differ greatly across these aquatic environments. What are some of the ways in which lakes, streams, and oceans differ from each other? The movement of water is one of the obvious factors; streams and rivers can have rapidly flowing water, and lakes can have less movement of water. Winds create the movement of surface waters in the oceans, setting up ocean currents and creating zones of upwelling. These winds, in addition to deep-water currents, move nutrients, organisms, oxygen, and heat around the world. As in the oceans, water movement affects various properties of the water in all aquatic habitats. Physico-chemical factors, such as pH, oxygen availability, salinity (Table 4.2), phosphorus, nitrogen, sulfur, and carbon availability, and macro- and micronutrient availability may differ widely within and across these different habitats. Streams and lakes differ from each other substantially. Streams are very patchy, have large changes in their physico-chemical conditions, are highly influenced by their drainage area, and have a flow of water in one direction. Lakes, on the other hand, possess more stable physicochemical conditions and more primary productivity, especially in comparison to stream headwaters. Lakes can be acidic or alkaline (e.g., Mono Lake in California), and although one thinks of them as being freshwater, they can occasionally be more salty, such as the Great Salt Lake in Utah.

Do different aquatic habitats have similar microbial populations? The evidence from scientific studies suggests that different phylogenetic groups are found in freshwater and marine habitats. Substantial differences exist in the archaeal representatives, as many are found only in the oceans, where their roles in the ecosystem are still largely a mystery. Archaea from both major phyla make up a large percentage of the ocean's picoplankton. Overlap in the bacterial phylogenetic groups between marine and freshwater habitats is seen at the phylum level, for example, in the Alphaproteobacteria (SAR11 clade), Actinobacteria, Cytophaga/Flexibacter/Flavobacterium group, but differences are seen as one moves to the lower taxonomic units (Pernthaler and Amann 2005).

Studies of aquatic microbial ecology have progressed from descriptive studies of "who's home" to hypothesis-driven studies of interactions and environmental and biological controls on diversity and population distributions, although big surprises about who lives in these habitats are still being discovered. Two interesting features of aquatic microorganisms and the focus of many studies is their variety of antipredation mechanisms, which include the secretion of exopolymeric substances and capsules consisting of polysaccharides and morphological adaptations, and the fact that they are Gram-positive. Studies have focused on how the microbial populations evade predators, as

TABLE 4.2. Characteristics of Different Aquatic Habitats

Aquatic Habitat	Temperature Range	Salinity (%)
Oceans	-1.5 to 27°C at surface	3.5
Rivers	0-30°C	0.001-0.05
Lakes		
Freshwater	4-50°C	0.01
Great Salt Lake		avg. 12%

Source: Data drawn from Molles (2008) and [http://www.utah.com/stateparks/great\\_salt\\_lake.htm/](http://www.utah.com/stateparks/great_salt_lake.htm/).

predation, particularly by protists, and lysis by viruses are two of the major factors that cause mortality. Viruses have been found to be widespread across a variety of aquatic habitats, with a difference of only one to two orders of magnitude across these different habitats (Wilhelm and Matteson 2008), although more seasonality is seen in freshwater viral abundances. What controls viral abundance in aquatic environments is still under investigation. The amount of virus burden has been estimated at 5–25% of the bacterioplankton in aquatic systems, with higher levels recorded for anoxic waters and sediments, where viruses appear to be more important agents of mortality [reviewed in Wilhelm and Matteson (2008)]. Viruses play a strong role in the regeneration of dissolved organic matter in aquatic systems as they lyse their prey, transforming the carbon and other nutrients in the bodies of their prey.

### 4.3.1 Freshwater

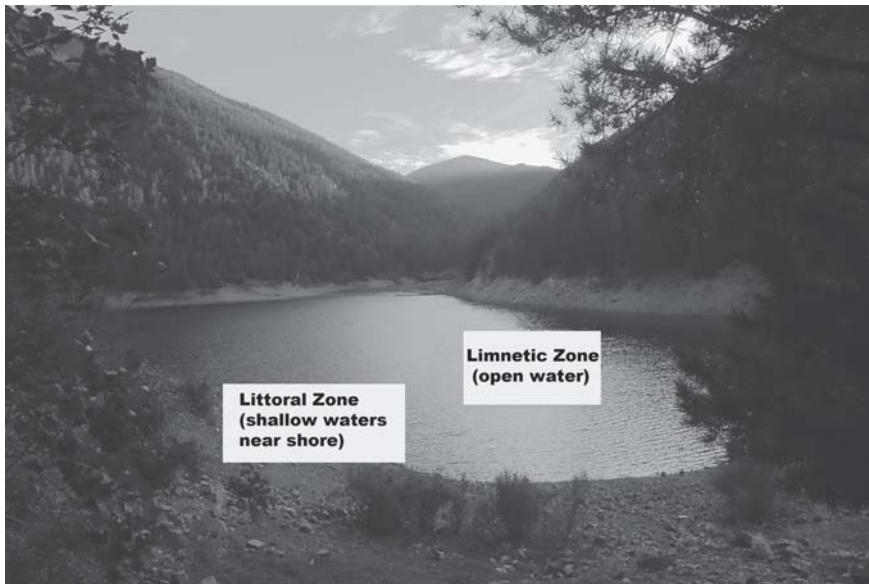
The term *freshwater habitats* generally refers to rivers, streams, lakes, ponds, and groundwater. The United States Geological Survey (USGS) defines freshwater as water that contains less than 1000 mg/L of dissolved solids. As noted above, the phylogenetic diversity of freshwater microorganisms differs substantially from that of marine habitats. Pernthaler and Amann (2005) note that typical freshwater bacterial groups include members of the Betaproteobacteria (e.g., relatives of *Rhodospirillum rubrum* and *Polynucleobacter necessarius*), the acI clade of the Actinobacteria, and relatives of *Haliscomenobacter hydrossis* in the Cytophaga/Flexibacter/Flavobacterium group.

**Lakes.** Lakes are water-filled basins (Figure 4.2) that were originally created by glaciation, volcanism, or tectonics. A few particularly large lakes, the Great Lakes in North America and Lake Baikal in Siberia, contain roughly 40% of the world's freshwater (Molles 2008).

Within bodies of water many gradients exist that affect the distribution of microbial populations. One of the most important of these is the oxygen gradient. This gradient is particularly dramatic in lakes, where the upper waters can be oxic and warmer (the epilimnion), while the lower levels are colder and sometimes anoxic (the hypolimnion). These two layers are separated by a boundary termed the *thermocline*, which represents a transition zone between the two layers. Seasonal changes in environmental temperature, and hence water temperature, can lead to density changes that result in the water turning over, bringing oxygenated water to the lower reaches of the lake. Such changes affect the microbial populations in the lake.

Vegetation surrounding lakes provides some of the nutrients found dissolved in lakes. Lakes with low amounts of nutrients are oligotrophic, while those with high nutrient loads and productivity are eutrophic and may experience oxygen depletion, which will affect the organisms that can survive under these conditions. Some lakes are naturally acidic, while others become acidified as a result of the transformation of pollutants such as sulfur dioxide and nitrous oxide (NO<sub>x</sub>) in acid rain. Lakes in northeastern North America are recovering from the effects of acid rain. The pH of lake water also affects the microbial populations (see Section 9.9.1).

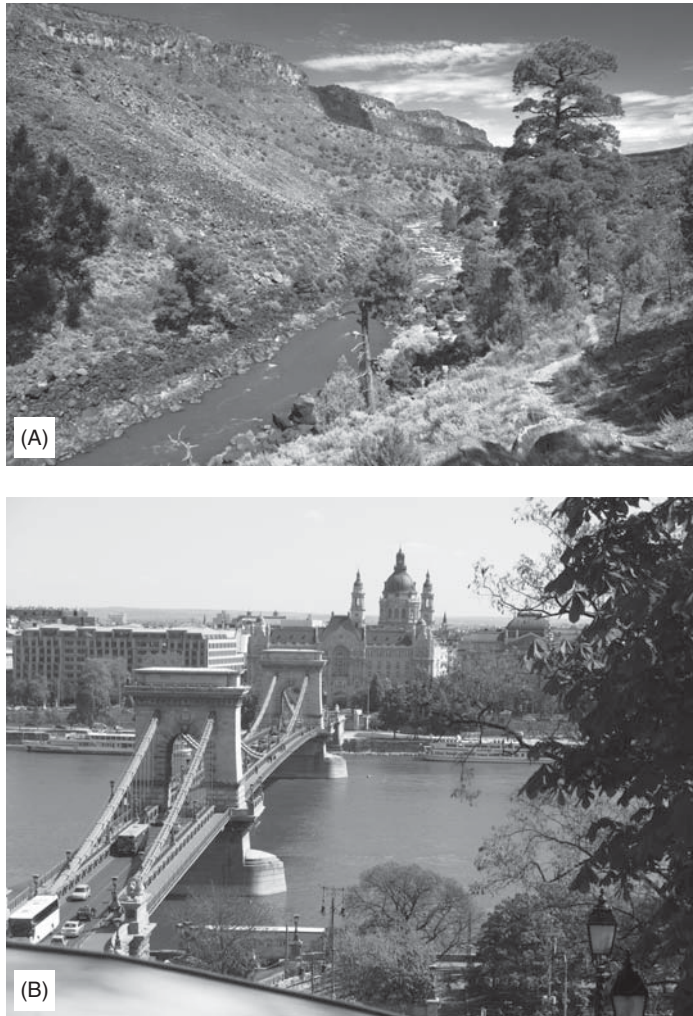




**Figure 4.2.** Lakes are a primary habitat for microorganisms (image courtesy of Kenneth Ingham).

**Rivers and Streams.** If you've ever watched river water change during and after a rainstorm, you'll get a sense of the power of the movement of water in rivers. Large amounts of material, soil, trees, rocks, and other substances are moved by the water in streams and rivers. This means a continual supply of nutrients for biotic communities, but also lots of disturbance during flooding events. Many rivers run through towns (Figure 4.3) and are therefore subject to the influx of human wastewater and other pollutants, which can strongly affect river inhabitants. Because microorganisms are so metabolically diverse, some of the pollutants will actually be energy sources for the microorganisms. Because high organic load can lead to high productivity, which decreases oxygen levels, areas of rivers in cities, for example, can be anoxic, limiting the kinds of microorganisms that can persist in these regions.

The river habitat is made up of several different components, including the horizontal components of (1) the *active channel*, which in some rivers and streams may go dry part of the year and (2) the *riparian zone*, which forms a transition zone between the terrestrial and aquatic ecosystems. Vertically, rivers and streams are characterized by (1) *surface waters*; (2) the *hyporheic zone*, which lies beneath the surface water; and (3) the *phreatic zone*, which contains the groundwater. These habitats vary in their physicochemical characteristics. Rivers and streams tend to have many organic and inorganic particles in suspension, which limits the extent to which light penetrates into the water column. The parts of the reach that have extensive vegetation will be at least partially shaded by trees hanging over the streams. Both turbidity and shading limit the level of photosynthesis that occurs by microorganisms within the streams. Desert streams (Figure 4.3), with little shading, have much higher levels of microbial photosynthesis than do those in tropical and temperate regions. Rivers and streams also vary by as much as an order of magnitude in their levels of salinity; desert rivers have the highest levels.



**Figure 4.3.** (A) Rio Grande running through the Wild and Scenic Rivers Area north of Taos, New Mexico (USA); (B) the Danube River that runs through Budapest, Hungary. (Photos courtesy of Kenneth Ingham).

**Hot Springs.** Hot springs are springs of geothermally heated water, groundwater that comes in contact with hot rocks, or in volcanically active regions, magma, which emerge from Earth's crust worldwide. Some spectacular examples, such as the Grand Prismatic Spring (Figure 4.4), are found in Yellowstone National Park in Wyoming (USA), Iceland, Japan, and New Zealand. Hot springs represent extreme environments in terms of temperature, and in some cases, pH. Many terrestrial hot springs have low oxygen concentrations, suggesting the presence of anaerobic or microaerophilic microorganisms. *Aquificales* have been suggested to be primary producers in hot springs, where temperature limits photosynthesis. Hyperthermophiles are often chemoautotrophs, utilizing carbon dioxide as their carbon source, and acting as primary producers within hot spring habitats. Hot springs vent a variety of dissolved gases, providing a range of electron



**Figure 4.4.** Yellowstone's Grand Prismatic Spring, Wyoming (USA) (image courtesy of Kenneth Ingham). See insert for color representation.

donors such as molecular hydrogen and reduced iron and sulfur compounds. Spear et al. (2005) suggest that at least in Yellowstone, the primary productivity comes from the oxidation of molecular hydrogen, which can occur in levels great than 300 nM in the hot springs. Archaeal species find hot springs a prime habitat.

#### 4.3.2 Marine Habitats

**Oceans.** Have you ever been swimming in the ocean or sailed out into the ocean? What do you notice about the ocean environment that's different from that of terrestrial habitats? Your first observation, beyond the fact that it's an aquatic rather than terrestrial habitat, is probably that the ocean is salty. This is one of several environmental parameters that shape the nature of microorganisms inhabiting marine habitats. In addition, as you go from the surface to the depths of the ocean, gradients of temperature, light, availability of nutrients, and pressure change. The ocean's habitats change with distance from shore (Figure 4.5) and vertical depth. As you move deeper into the ocean you move from the surface or epipelagic zone to the mesopelagic zone (200–1000 m) to the bathypelagic zone (1000–4000 m), to the abyssal zone (4000–6000 m), and finally to the hadal zone (<6000 m).

**Marine Microbial Habitats and Food Webs.** In general the marine food web is shaped by the low availability and patchy nature of nutrients, and the gradients and high salinity mentioned above. Our view of “who's home” and who's controlling the cycling of nutrients in the ocean food web has changed dramatically in more recent decades. Compare the following (Pomeroy 1974) quote with other information presented in this chapter:

Although the ocean's food web has been studied for more than a century, several recent discoveries lead us to believe that the classical textbook description of a chain from diatoms through copepods and krill to fishes and whales may in fact be only a small part of the flow of energy. Recent studies of microorganisms, dissolved organic matter, and nonliving



**Figure 4.5.** Oceans, such as this view of the Pacific Ocean off the coast of Queensland, represent the largest aquatic habitats (image courtesy of Kenneth Ingham).

organic particles in the sea suggest the presence of other pathways through which a major part of the available energy may be flowing. Marine scientists have been approaching this view of the food web cautiously for decades, and caution is to be expected whenever an established paradigm is questioned.

To understand the differences between the older and newer views of the marine food web, DeLong and Karl (2005) depict the more classic marine food web with the microbial food web (Figure 4.6). This view of the marine food web shows the central importance of microorganisms in converting dissolved organic carbon to forms usable by higher trophic levels. We now know that oxygenic photosynthetic picoplankton are the dominant organisms in plankton and play a key role in the oceans' food web. We have learned that viruses exist in greater numbers than do bacteria and help control the species diversity of bacteria. The role of archaea in the oceans remains largely a mystery. Despite tremendous advances in our knowledge of the ocean's food web, huge gaps in our understanding still exist. You can learn more about what is known by reading DeLong and Karl (2005).

From both soil (Figure 4.7) and marine ecosystems we have learned that microorganisms are tremendously important in cycling key nutrients, such as carbon, nitrogen, and phosphorus, within and between ecosystems.

#### 4.4 SOIL HABITATS

Soils are widespread and important habitats for microorganisms, which play key roles in providing nutrients to plants. If you dig a hole in the ground, you'll notice that there is a structure to the soil, with different levels in evidence (Figure 4.8). These include the organic horizon (*O* horizon) at the top, which includes freshly fallen litter on top through partially decomposed organic matter farther down, followed by the *A* horizon, which

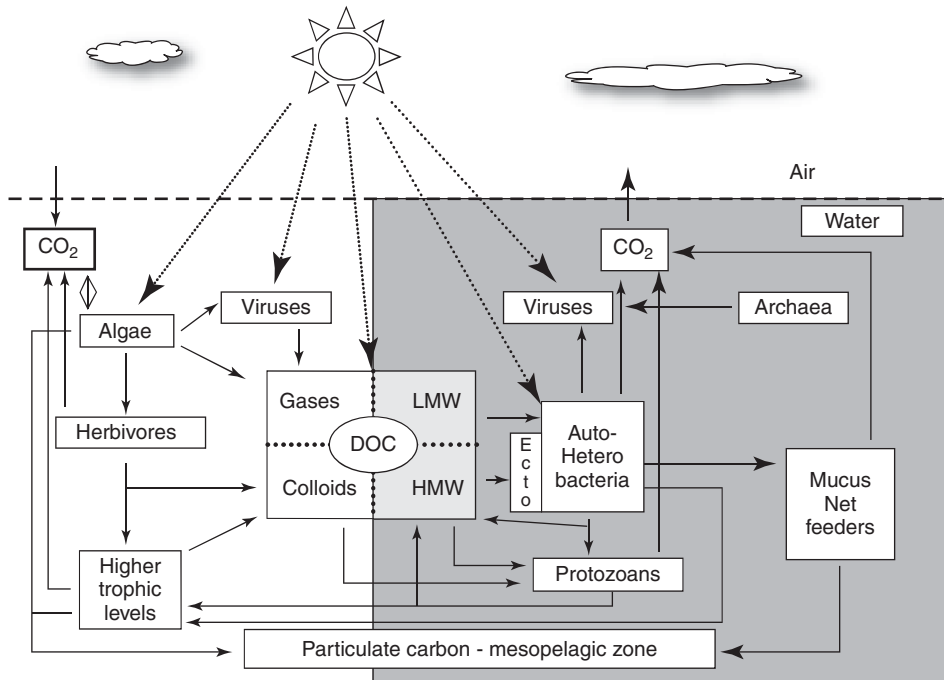


Figure 4.6. The classic marine food chain is contrasted with the new view of the importance of microorganisms in the ocean's food web [modified from DeLong and Karl (2005)].

contains a variety of minerals (Figure 4.9), the *B* horizon where humus, clays, and other transported materials reside, and finally, the *C* horizon of weathered parent material. The depth of these layers can vary dramatically, with thin soils overlying limestone regions of the world, such as the Yucatan, and thick soils occurring in some of the rich farmlands, such as found in the midwestern United States. Areas where heavy rainfalls occur, such as the tropics, have nutrient-poor soils because the rains leach nutrients from the soils over time. Permeability of the soil can affect the degree to which nutrients and microorganisms can move around. Beneath the first centimeter or two, light does not penetrate, removing phototrophy as a means of acquiring energy. The area around plant roots, the rhizosphere, is a habitat where abundant microbial populations occur.

#### 4.4.1 Microbial Food Webs in the Soil Habitat

One of the largest treasure troves of novel species—antibiotics, and insights into how communities are structured—exists in Earth's soil ecosystems. Each gram of soil has  $10^9$  bacterial cells on average, representing up to 5000 [or even 10,000; see Torsvik et al. (1996)] species of bacteria by some estimates. The structure and inhabitants of the soil food web are more complex than you might imagine (Figure 4.10). Depending on the aridity of the aboveground environment, plants play a major role in physically structuring the below ground environment through their roots and the effects of their aboveground canopy. Much of the study of the soil biota has concentrated on the larger organisms in the soil, such as earthworms, mites, springtails, nematodes, protists, and



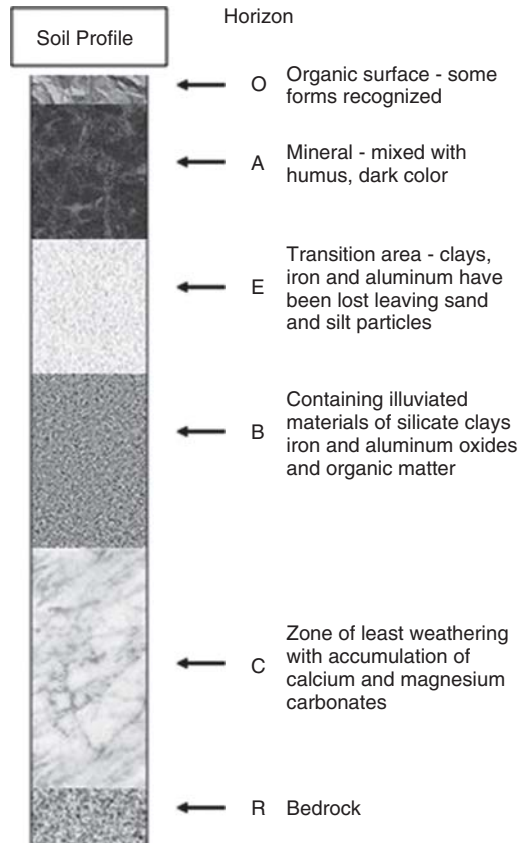


**Figure 4.7.** Litter from vegetation contributes inorganic and organic nutrients to soil habitats, while nitrogen-fixing bacteria and other microorganisms make nitrogen, phosphorus, and other nutrients available for plant uptake in the rhizosphere [image courtesy of Kenneth Ingham; modified from van der Heijden et al. (2008)].

other invertebrates (Coyne 1999). Through their ingestion and excretion of parts of the soil, these organisms help “engineer” the soil environments. Bacteria and fungi also serve as engineers on the microenvironment scale.

Microbial abundance in soil varies with physical and chemical characteristics of the microenvironment, including moisture content, abundance of organic matter, and size of soil aggregates. While seasonal changes contribute to the dynamics of microbial soil communities, discussions of microorganisms in the soil generally refer to topsoil sampled in the growing season. As determined by plate count methods, the most abundant microorganisms in the soil follow this pattern (see also Table 4.3):

Aerobic bacteria > anaerobic bacteria = actinomycetes > fungi > algae

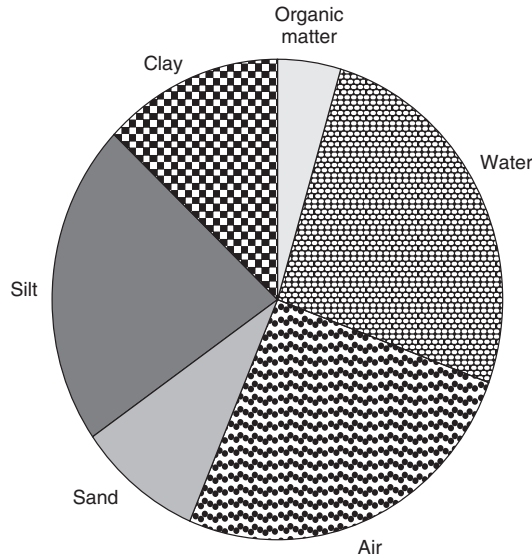


**Figure 4.8.** Model of Mollisol profile showing different horizons [modified from Coyne (1999)].

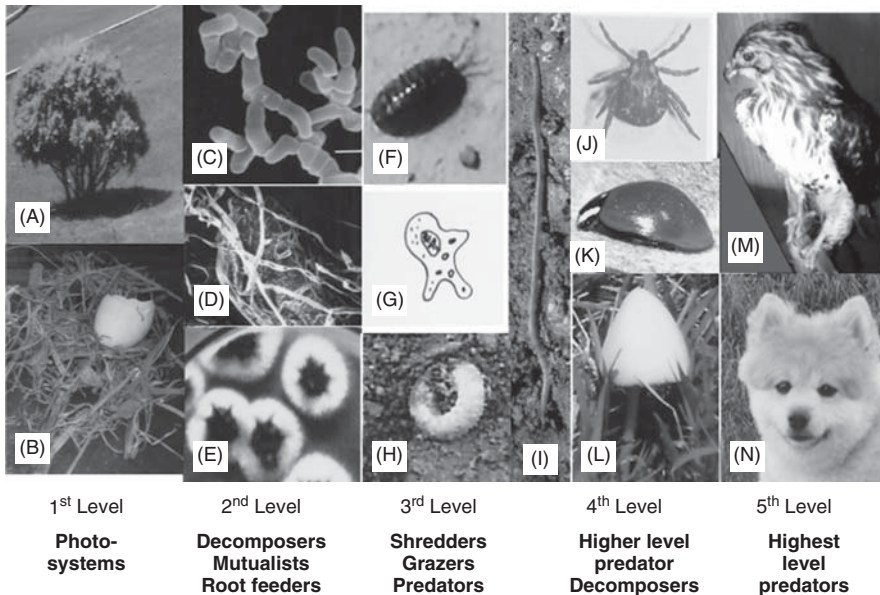
Microorganisms are most abundant at the surface, and they decrease in colony-forming units as the depth increases. The impact of soil types including different organic content and related microbial processes is seen in the variation of physiological types of bacteria in different soil environments (Table 4.4). Bacteria in soil have considerable genetic diversity, and many of the physiological groups have yet to be cultivated in the laboratory. Thus, for analysis of the soil community, molecular techniques produce more information than traditional plating exercises.

Almost all major microbial groups are found in soils: bacteria, viruses, fungi, and archaea. Progress has been made on delineating what groups are most prevalent in soil communities using culture-independent methods. Janssen (2006) analyzed 32 different libraries of sequences from different soils. Their findings are impressive: 32 different phyla were found across the studies, but 9 phyla dominated: Proteobacteria, Acidobacteria, Actinobacteria, Verrucomicrobia, Bacteroidetes, Chloroflexi, Planctomycetes, Gemmatimonadetes, and Firmicutes (Janssen 2006). The Proteobacteria make up the largest percentage (39% on average) in soils. Most of the sequences were novel, and the conclusions of this analysis differ markedly from those found in prior decades from cultivation studies. With such a bewildering array of facts and figures, how do you figure out what's most important?





**Figure 4.9.** Pie chart illustrating distribution of substances in the A horizon of a Mollisol. Air and water make up the void space (50%); sand, silt, and clay constitute the mineral material (45%); while dead and live organisms make up the organic matter (5%). [Modified from Coyne (1999)]. See insert for color representation.



**Figure 4.10.** An example food web illustrating relationships in the soil: (A) shrub and grass; (B) bird egg on leaves and branches; (C) microcolony of bacteria; (D) mycorrhizal fungi on plant root; (E) colonies of soil fungi; (F) sow bug; (G) an amoeba; (H) cut worm; (I) earthworm; (J) deer tick; (K) ladybug; (L) mushroom; (M) red-tailed hawk; (N) Pomeranian dog. [Image (C) provided by Jane Gillespie; (I) and (K) courtesy of Kenneth Ingham; all other photographs provided by Larry Barton; modified from [http://soils.usda.gov/sqi/concepts/soil\\_biology/soil\\_food\\_web.html](http://soils.usda.gov/sqi/concepts/soil_biology/soil_food_web.html)]. See insert for color representation.

TABLE 4.3. Abundance of Microorganisms (Organisms  $\times 10^3$  g<sup>-1</sup> Soil) in a Leached Sandy Soil of a Cool Coniferous Forest, Spodosol

Depth (cm)	Aerobic Bacteria	Anaerobic Bacteria	Actinomycetes	Fungi	Algae
3–8	7800	2000	2000	120	25
20–25	1800	380	245	50	5
35–40	470	100	50	14	<1
65–75	10	1	5	6	<1

Source: Modified from Coyne (1999).

TABLE 4.4. Distribution of Physiological Groups of Bacteria<sup>a</sup> in Various Soil Types

Physiological Group	Field	Meadow Forest	Coniferous	Wetland
Aerobic heterotrophic bacteria	8,100,000	8,100,000	1,500,000	1,500,000
Anaerobic heterotrophic bacteria	137,000	620,000	345,000	2,180,000
Nitrifying bacteria	1,700	37	<1	34
Denitrifying bacteria	400	850	380	370
Nitrogen fixing (aerobes)	1,800	18	<1	17
Nitrogen fixing (anaerobes)	700	370,000	2,000	67
Anaerobic butyric acid bacteria	50,000	83,500	200,000	235,000

<sup>a</sup>Expressed as colony-forming units per gram of soil.

Source: Modified from Pelczar et al. (1977).

Two key, major groups of bacteria in soil that have been studied extensively are symbiotic nitrogen fixers (see Section 2.4.2) and mycorrhizae, which provide 5–20% of grassland and savannah nitrogen and 80% of nitrogen in temperate and boreal forests. At least 20,000 plant species depend on nitrogen and phosphorus derived from symbiotic microorganisms (van der Heijden et al. 2008). Plants need nitrogen, and without their symbiotic partners, they cannot fix atmospheric nitrogen to a useful form. *Frankia*, an actinomycete that is important in the growth of forests, and *Rhizobium*, which is a key player in the health of crop legumes, are examples of important nitrogen-fixing bacteria. Associations between plants, such as the alder tree (*Alnus*) and *Frankia*, allow these trees to grow in more marginal areas where nitrogen is limiting. More than 25 different genera of trees and shrubs have been documented to grow in association with *Frankia* (Coyne 1999). Rhizobia, including *Azorhizobium*, *Bradyrhizobium*, and *Rhizobium*, are chemoheterotrophs, free-living in the soil or in association with a wide variety of legumes including alfalfa, clover (Figure 4.11), lupines, and soybeans. Plants release chemical compounds to attract soil rhizobia to infect them. Most of the nodules form on root hairs, but some form on stems. Nodules can utilize 7–12% of the plant's photosynthetic output while active (Coyne 1999), but the return in the form of fixed nitrogen available to the plant is well worth the cost.

Despite the progress we've made in understanding soil food webs, significant challenges are hampering our understanding of what structures soil food webs. Different feeding groups are aggregated commonly because most soil organisms are very "flexible" in their feeding habits, muddying the distinctions between trophic levels. The diets of very small organisms are relatively unknown. New molecular techniques such as



**Figure 4.11.** Rhizobia, living in a symbiotic association with plants such as clover, are one of the major groups of nitrogen fixers in agricultural ecosystems (image by Kenneth Ingham; used with permission).

fluorescent *in situ* hybridization (FISH; see Section 5.4.4) represent exciting tools that can help reveal the complex interactions of who eats whom in the soil community. Stable-isotope analysis is another tool that is used to reveal feeding relationships and energy sources (see Section 5.11). Scheu (2002) provides a great review of the use of these techniques to reveal that trophic levels grade into each other rather than form distinct levels.

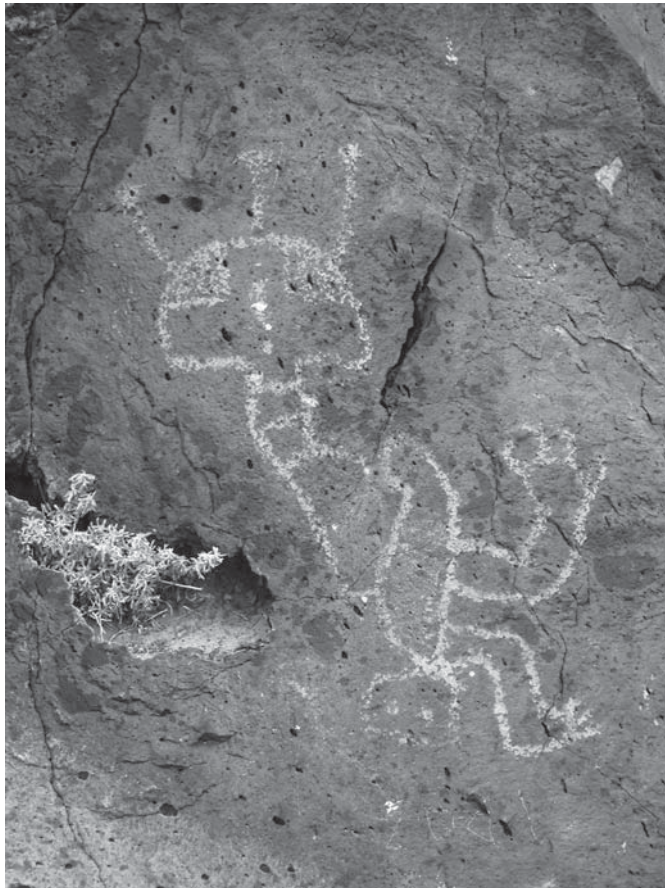
## 4.5 ROCK AND SUBSURFACE HABITATS

### 4.5.1 Rock Varnish

Exposed rock surfaces in many parts of the world, particularly in arid and semiarid environments, are often covered or streaked with a red-brown to black patina, called *rock* or *desert varnish*. These rock surfaces on which the varnish builds can be of many

different types (e.g., sandstone or andesite), and represent a harsh habitat with infrequent rainfall and abundant ultraviolet radiation, which are significant stressors for life. A vigorous debate has been conducted as to whether these ferromanganese varnishes are created partially or totally by microorganisms (see Section 11.8.2). Their importance as palettes for artwork makes this an important debate (Figure 4.12).

**Endolithic Habitats.** Living within the rock seems like a rather unimaginable place to find life, but the pore spaces within rocks are a widespread habitat for microorganisms, which are termed *endolithic* microorganisms. Rock, as a habitat for life, has been known for decades, but it was not until the 1980s when E. Imre Friedmann and associates published accounts of this life, that endolithic microorganisms became more widely known (Walker and Pace 2007). Studies of endoliths in Antarctica shed light on life detection in extraterrestrial environments, where such a habitat would protect life from hostile conditions. What are some of the environmental conditions from which such a



**Figure 4.12.** Petroglyphs are often created by removing part of the rock varnish, exposing the lighter-colored original rock below (image by Kenneth Ingham; used with permission).

habitat would offer protection? Radiation from the sun, especially ultraviolet radiation, desiccation, and large variations in temperature are important environmental stressors, which living within rock helps to minimize. Mineral composition of the rock, the nature of the pore spaces, nutrient sources, and climate in which the rocks occur, particularly the frequency of precipitation, influence the nature of the microbial communities that live within the rock. In hot deserts, water often results from overnight condensation, as dew, of moisture in the air, which is absorbed by rocks. Microorganisms colonize a few millimeters to centimeters from the surface of rocks, depending on different abiotic factors, with photosynthetic organisms preferring regions near the surface that receive more light.

#### 4.5.2 Cave Habitats

Caves extend a few meters to thousands of meters below the Earth surface and offer a variety of microbial habitats (Figure 4.13). The parent rock in which caves form is often limestone or volcanic, but can be dolomite, gypsum, sandstone, granite, marble, or other rock types. The mineral composition of these different lithologies can affect the types of nutrients that may be available for microorganisms. Low, but measurable levels of nitrogen and organic carbon occur within the rock walls of caves. Caves that have streams or rivers running through them have higher levels of organic carbon available, while caves in arid lands may be very oligotrophic. Cave habitats beyond entrance/twilight zones are characterized by very high relative humidity that approaches 100%, total darkness, low nutrient levels, and stable temperatures. Exceptional habitats within caves may occur where reduced gases vent into the cave or bat colonies deposit large amounts of guano.



**Figure 4.13.** Rock surfaces and interiors of caves offer habitat and nutrient sources for microorganisms (image by Kenneth Ingham; used with permission).



### 4.5.3 Groundwater

Groundwaters provide important habitats for microorganisms and have been characterized by Griebler and Lueders (2009) as the “largest habitat for microorganisms on earth,” which may harbor up to 40% of Earth’s archaeal and bacterial biomass. Groundwater ecosystems differ from terrestrial and surface aquatic habitats in their lack of readily available, fresh carbon and sunlight. Heterotrophs adapted to low nutrient (oligotrophic) conditions predominate in many areas, as well as chemolithoautotrophs, which have been more recently characterized. These aquifers are similar to cave environments in their stable conditions, and in fact, caves are an important reservoir of groundwater from which we obtain a large percentage of our drinking water. Groundwater habitats can be somewhat small, such as those associated with streams, or can be gigantic, covering hundreds of kilometers. One of the key features of groundwater habitats is their hydrologic interconnectivity, which allows for the transfer of nutrients and organisms over large areas.

More recent research has begun to piece together the microbial diversity and the biogeochemical processes that occur within these habitats. Evidence suggests that residence time of water increases from days near the surface to centuries or much longer deep within the subsurface and that bacteria, archaea, fungi, and protozoa are found in groundwater. The latter two groups are found mainly in groundwater near the surface. The various species of bacteria number between  $10^2$  to  $10^6$  per  $\text{cm}^3$  of groundwater, with higher numbers of cells found on sediment particles (Griebler and Lueders 2009). Molecular phylogenetic studies of groundwaters have revealed many novel species, but Griebler and Lueders (2009) argue that “no clearly ‘endemic’ subsurface microbial phyla have been identified.”

### 4.5.4 Deep Subsurface

As you travel deeper within Earth’s crust, life is still found within the pore spaces and has been found several kilometers beneath Earth’s surface. Studies of the sediments at the ocean’s bottom by ocean drilling program participating scientists have revealed cells up to 800 m down in the bottom sediments. The number of cells varies with depth from  $10^8$  or  $10^9$  near the surface of the sediments, to  $10^5$  or  $10^6$  at lower levels (Teske 2005). Sediments in the vicinity of deep-sea hydrothermal vents are being investigated and studies of midocean ridge basalts with more moderate-temperature vent fluids are documenting microbial communities subsisting on the oxidation of reduced iron and sulfide. Some vents are covered by thick layers of sediments, which provide warm, anaerobic habitats with higher levels of organic substrates for microorganisms (Amend and Teske 2005). Continental deep subsurface biospheres differ from marine deep subsurface habitats, but investigations have also included studies of basalts, as well as granitic rock, deep mines, and sedimentary deposits. The studies included organisms such as methanogens, acetogens, various heterotrophs, and sulfate and iron reducers and revealed indications of the energy sources available (Table 4.5), with hydrogen generated by rock–water interactions playing a key role. A vigorous debate has centered around the degree to which molecular hydrogen dominates as the electron donor in this environment. The  $\text{H}_2$  comes from one of three possible sources (Amend and Teske 2005):

TABLE 4.5. Reactions in Deep Granitic Subsurface<sup>a</sup>

Reactions	Responsible Microbial Group (Products)
$4\text{H}_2 + \text{CO}_2 \rightarrow \text{CH}_4 + 2\text{H}_2\text{O}$	Methanogens (methane)
$4\text{H}_2 + \text{CO}_2 \rightarrow \text{CH}_3\text{COOH} + 2\text{H}_2\text{O}$	Acetogens (acetic acid)
$\text{CH}_3\text{COOH} \rightarrow \text{CH}_4 + \text{CO}_2$	Methanogens (methane)
$\text{CH}_3\text{COOH} + \text{SO}_4^{2-} + 2\text{H}^+ \rightarrow 2\text{CO}_2 + \text{H}_2\text{S} + 2\text{H}_2\text{O}$	Sulfate reducers (hydrogen sulfide)
$\text{CH}_3\text{COOH} + 8\text{FeOOH} + 16\text{H}^+ \rightarrow 2\text{CO}_2 + 8\text{Fe}^{2+} + 14\text{H}_2\text{O}$	Iron reducers (ferrous iron)

<sup>a</sup>As suggested by Pederson (1997), reviewed in Amend and Teske (2005).

- Deep, volcanic magmatic gases
- $\alpha$ -Radiation-driven radiolysis of water
- Water–rock interactions in which oxygen-depleted water comes in contact with iron-containing rocks

If hydrogen doesn't drive the subsurface biosphere, other sulfur and iron species are possible sources of reducing power. Exactly what fuels the deep subsurface habitat is an exciting research frontier.

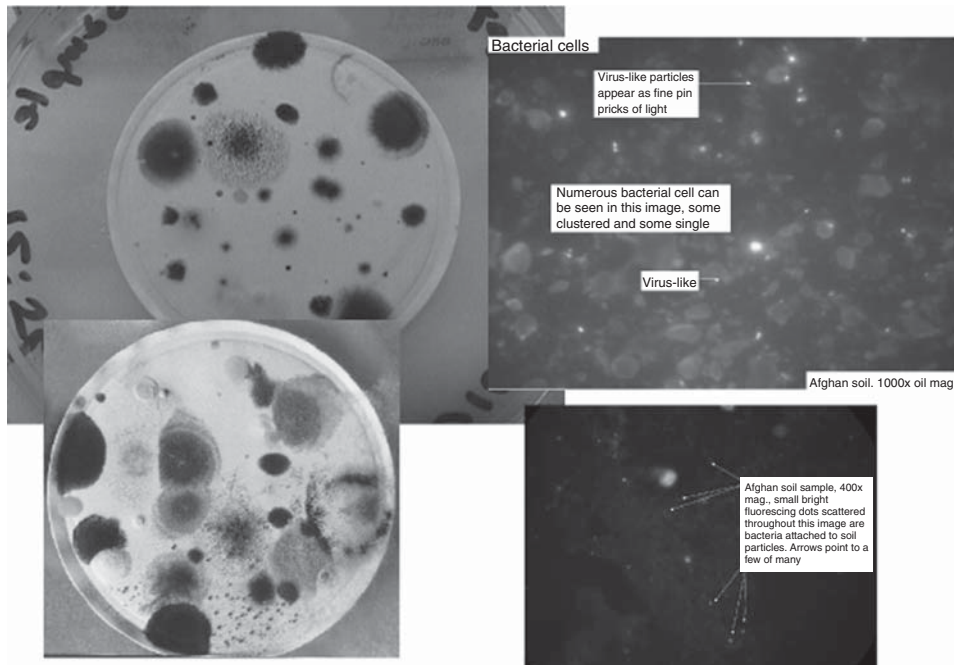
## 4.6 ATMOSPHERIC HABITATS

### 4.6.1 Atmospheric Microbial Diversity: African Dust

The microbial community (is it a community?) of the atmosphere is potentially a vehicle for pathogen transport, but little research has been carried out on this important habitat. Our lack of knowledge is noted by Dale Griffin (2007; see “microbial spotlight” in Section 4.6.2), who cites from a paper published by Fred C. Meier and Charles A. Lindbergh in 1935: “While it is generally known that bacteria, spores of higher fungi and pollen grains are present among dust particles in the atmosphere near the earth's surface, much detailed information of practical value remains to be revealed by further research.”

Dust storms loft desert soil particles, often with attached microorganisms, high into the air. Many have thought that ultraviolet light, temperature, and desiccation would kill transported microorganisms, but we are now learning that many bacteria and especially fungal spores are resistant to these stressors. Microorganisms survive over long distances and times, to land on distant terrains. Travel over marine environments results in dust particles acquiring marine organisms from marine aerosols (Figure 4.14). Various bacteria have been found in atmospherically transported dust, including species of *Bacillus*, a spore former, genera of Actinobacteria (e.g., *Streptomyces*, *Microbacterium*, *Kocuria*), and genera of the Alphaproteobacteria such as *Sphingomonas*. These correspond to many of the dominant groups in soils. Because of their strong resistance to environmental stresses, many fungal spores are found associated with atmospherically transported dust. *Aspergillus* spp. are frequently found, but a diverse community of fungi has been detected,





**Figure 4.14.** Epifluorescent and macroscopic images of bacteria, fungi, and possible viral particles from dust (images courtesy of Dale Griffin, USGS). See insert for color representation.

especially over regions with more vegetation and human activity. Some of the bacterial and fungal species found are potential plant, animal, or human pathogens, but how strongly dustborne pathogens are linked to disease outbreaks is not well known. Studies indicate that there is some human health risk associated with the opportunistic pathogens found in dust, but much remains to be done.

As more culture-independent techniques are utilized in these studies, our knowledge of this community will expand. Comparisons with urban aerosol studies conducted to provide baseline data for detecting bioterrorist threats will provide a more complete picture of microorganisms transported through the atmosphere. Studies of dust communities will provide important information on pathogen transport and the ability of microorganisms to survive harsh conditions.

#### 4.6.2 Mysteries Remain

On an ocean drilling program cruise, Dale Griffin noticed small air pockets in the core with what look like filaments emerging from the air pocket. Intrigued by these filaments he played with them under the microscope and hit one of the filaments with UV light. It changed shape! When the UV light was removed, it resumed its former shape. To this day, he has no idea why they did that or what he was looking at. Do you have any ideas about what might causes this phenomenon?

**Microbial Spotlight****DALE GRIFFIN**

Dale Griffin sampling microbes in the atmosphere of Carlsbad Cavern, New Mexico.

When you watch Dale Griffin sample the air and consequently the microbes in the air, you see a scientist intent on his work, possibly thinking about the diversity that will be revealed from his samples, whether they're from air gusting across from Africa or from the air that fills the voids of Carlsbad Cavern. A satellite image of dust coming off the African coast changed the course of his research in microbial ecology. Gene Shinn, who was to become his postdoc advisor at the USGS, sparked Dale's interest in the African dust question by sending him this photo. Dale began to wonder about what they would find and whether this could be the transport mechanism for disease epidemics between continents. Could the microbes survive the UV radiation? How many different microbes could there really be? In their first experiments they expected to find one or two microorganisms in a 200-L sample of air; they found 40 and were startled by the diversity they found. Rather than a environment dominated by spore-formers such as *Bacillus*, they found many different genera, including some of the pathogens that they predicted would be there. When Dale looks at samples from seawater microscopically, he sees a spectacular assortment of shapes, colors, and organisms—"It's like going to Disneyland!"

## 4.7 POPULATION ECOLOGY ACROSS HABITATS

Pernthaler and Amann (2005) define a *population* as a group or taxa of microorganisms that differ from other groups or taxa on a particular environmental parameter. One objective of microbial population ecology is to explain the distribution patterns of organisms by studying their physiology, their interactions with other organisms, the physiochemical properties of their environment, and genetic changes at the individual and population levels in response to environmental factors. This has been a major challenge in some habitats, such as aquatic environments, where populations of microorganisms can be abundant at a point in time and space, and rare at other spatial and temporal points. Bacterial populations tend to be large and to respond rapidly to environmental changes and other selection pressures. As with more familiar organisms such as mammals, microorganisms experience mutations in their genomes, which can be deleterious, beneficial, or in most cases, neutral. These mutations lead to heritable changes in microbial genomes, and natural selection acting on these variations and mutations that are beneficial, or adaptive, lead to higher fitness for these individuals. These changes in microbial genomes may also lead to speciation. Variation in microbial genomes and other DNA occurs as a result of

- Ultraviolet radiation
- Errors in DNA replication
- Gene duplication
- Horizontal gene transfer (Section 4.7.2)
- Gene loss, which can lead to genome reduction
- Homologous DNA recombination

Natural selection operates on this variation within populations, and organisms with beneficial changes in their DNA are favored. Over time, which can actually be very short in bacteria and archaea, the favored ecotype may replace the original ecotype in this environment. Many microbial investigations focus on populations, but it is important to remember that a great deal of phenotypic variation occurs within populations and that individual organisms are an important scale at which to perform research (Davidson and Surette 2008).

### 4.7.1 Population Growth and Dynamics

The amount of population growth by microorganisms in various habitats is governed to some extent by the level of resources available, which include micro- and macronutrients and electron acceptors and donors (Table 4.6).

Other abiotic factors, such as seasonality, temperature, and niche space, can contribute to population distributions. A study by Hunt et al. (2008) reveals habitat partitioning by various coexisting strains of Vibrionaceae at different temporal and spatial scales. They ask the following question: Do vibrio genotypes form ecologically coherent groups? Vibrio-type coastal bacterioplankton strains use dissolved nutrients within the water column (free-living Vibrionaceae) or may attach to and feed on suspended organic detrital particles or zooplankton. These three habitats vary in their level of nutrients, seasonal availability, and habitat stability. Through their evolutionary model (AdaptML),

TABLE 4.6. Nutrients, Electron Acceptors, and Electron Donors Influence Microbial Population Growth in All Habitats

Resource Category	Resources
Macronutrients	
Nitrogen	Organic or inorganic
Carbon	Organic or carbon dioxide
Other	S, P, Mg, K
Micronutrients	Mn, Fe, Ni, Co, Cu, Zn
Electron acceptors	O <sub>2</sub> , SO <sub>4</sub> <sup>2-</sup> , NO <sub>3</sub> <sup>-</sup> , Fe <sup>3+</sup> , Mn <sup>4+</sup>
Electron donors	Organic matter, H <sub>2</sub> , H <sub>2</sub> S, NH <sub>4</sub> <sup>+</sup> , Fe <sup>2+</sup> , Mn <sup>2+</sup>

Source: Modified from Madigan et al. (2009).

they were able to identify clusters of strains that were ecologically distinct populations with clear habitat preferences that included (1) populations that were free-living and particle-associated, but had no zooplankton associations; (2) populations associated with zooplankton and large particles; (3) fall-occurring free-living populations, and (4) spring-occurring particle and zooplankton-associated group. Groups 1 and 2 had no seasonal preference. One of their most striking conclusions is that strains of *V. splendidus* that differ by only one nucleotide in the *hsp60* gene, partition their habitats, and can be discerned as occupying different ecological niches and seasons. This study has two important considerations for understanding how microorganisms utilize habitats. Because of the difference in scale between humans that sample habitats, and the microbial niches within the habitat, it is difficult to really know what habitat we're sampling. Additionally, the lack of a good microbial species concept makes it difficult to use genetic relationships, and in particular, single marker genes, to partition microbial populations.

#### 4.7.2 Horizontal Gene Transfer

Not all genes are transmitted vertically during cell division. Substantial evidence has now accumulated to support the existence of horizontal or lateral gene transfer (HGT or LGT). In bacteria and archaea, HGT can occur through transformation, transduction, or conjugation. HGT among genes for metabolic functions and pathogenic virulence has been most commonly documented, while genes involved in core functions, such as DNA replication, transcription, and translation, reveal much less evidence of HGT, although this is debated. It is widely accepted that closely related strains of bacteria show extensive, more recent evidence of HGT, especially the insertion of pathogenicity or symbiosis islands of genes, likely by bacteriophages. However, on a larger scale, the degree to which HGT has shaped the evolution of bacteria and archaea has engendered a fierce debate (Koonin and Wolf 2008). Good evidence exists for the role of HGT in the transfer of genes involved in photosynthesis by cyanophages, which act as a gene transfer agent. Additionally, genomics has revealed that two thermophilic bacterial species, *Aquifex aeolicus* and *Thermotoga maritima*, contain many genes of archaeal origin, which were probably acquired from thermophilic archaea that share the environment with *Thermotoga*. Opponents of HGT suggest that examples such as these could be the result of protein sequence convergence among organisms that share a habitat, or that these cases represent the presence of genes that have been lost in all other organisms.

Overall, however, it appears that HGT is pervasive and important in evolutionary studies of bacteria and archaea and questions our use of current phylogenetic tree technology to represent evolutionary relationships (Koonin and Wolf 2008).

### 4.7.3 Biogeography versus Everything is Everywhere; the Environment Selects

“Everything is everywhere, but the environment selects.”

Or is it?

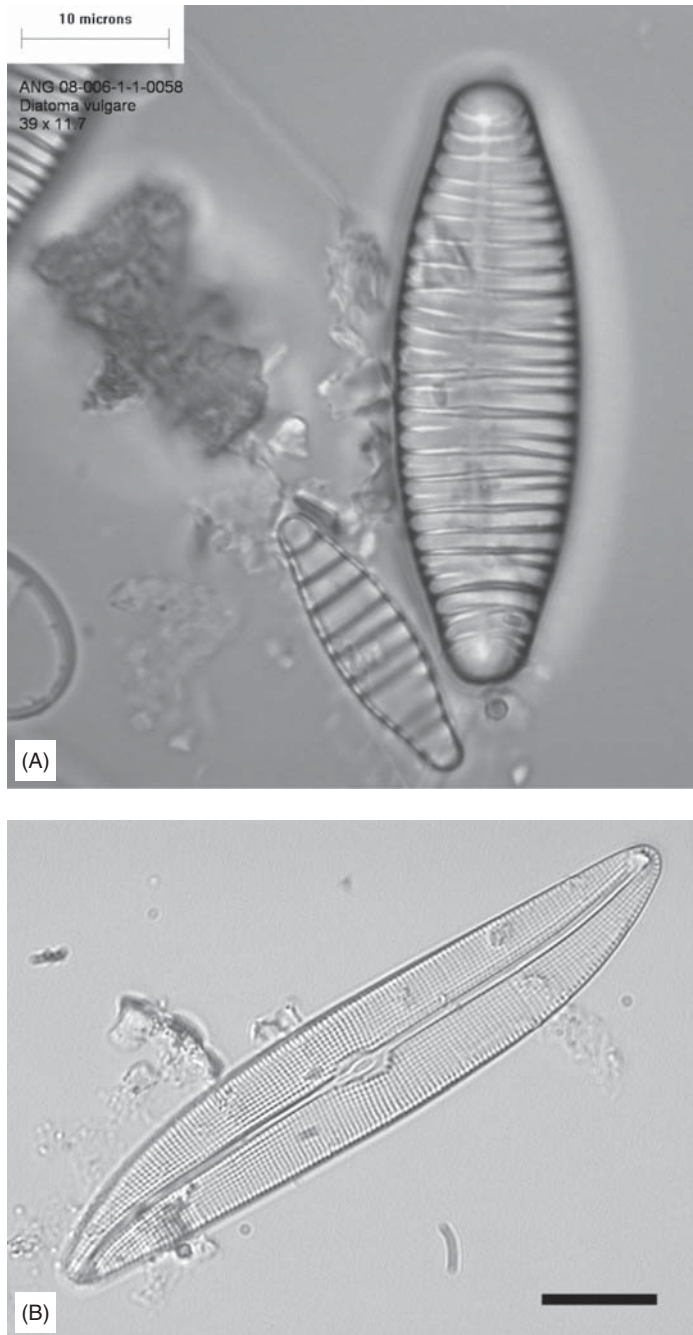
The notion that microorganisms, or “germs,” as Beijerinck referred to them, were cosmopolitan and that you could select which ones were present on the basis of the environmental conditions provided, was developed by Martinus Willem Beijerinck in the early 1900s. His ideas appear to have been framed against the backdrop of the earlier work of Candolle and Sprengel, who put forth the supposition that [quoted in O’Malley (2007) from an 1821 publication]

... the lower the organization of the body is, the more generally it is distributed. As infusory animalculae are produced in all zones, when the same conditions exist; we find in the same manner that Fungi, Sponges, Algae and Lichens . . . are distributed everywhere upon the earth, in the sea, and in the waters, when the same circumstances propitious to their production occur.

Beijerinck’s writings were the inspiration for the succinct wording, “Everything is everywhere, but the environment selects,” by Lourens G. M. Baas Becking in 1934, who de Wit and Bouvier (2006) argue should get the credit for this theory. The cosmopolitan nature of microorganisms theory enjoyed several decades of acceptance and elaboration (O’Malley 2007); however, the last decade (since the 1990s) has seen strong challenges to this theory.

Cosmopolitan microorganisms do exist; at the taxonomic level of class/phylum, Flavobacteria, Betaproteobacteria, Actinobacteria, and Cyanobacteria are distributed globally. Within habitat categories, such as hot springs, many of the same genera are found worldwide, and several pathogens, such as *Streptococcus pneumoniae*, are found globally. Clear examples of endemic bacterial genotypes have been found, such as *Sulfolobus “islandicus”* (Ramette and Tiedje 2006), supporting the idea that biogeographic patterns do exist for some microorganisms. General ecological theory suggests that dispersal, speciation, and extinction create biogeographic patterns. Various agents of dispersal, such as winds, migrating animals, and ocean currents, do aid microbial emigration to new habitats. Whether these microorganisms will be able to reproduce once they disperse to a new habitat will depend on their physiological flexibility in the new environmental conditions encountered. Some microbial populations do become geographically isolated and neutral mutations that occur in these populations could lead to speciation under some of the same conditions that are considered in macrobiology speciation. The degree to which extinction may structure biogeographic patterns in microorganisms is not currently known.

Diatoms (Figure 4.15), which are unicellular algae classified within the stramenopiles (Section 2.9.1) offer some insights into the distribution of a group that was formerly



**Figure 4.15.** (A) *Diatoma vulgare*, a freshwater, planktonic diatom; (B) *Gyrosigma sciotoense*, a freshwater sigmoid diatom that lives in sediment habitats (photos courtesy of Rebecca Bixby).



thought to be cosmopolitan. Soininen (2007) defines a cosmopolitan organism that does not exhibit biogeographic patterns in its distribution as one that has a

- High dispersal rate
- Distribution that spans continents
- Flat species–area curve
- Large ratio of local to regional/global species number
- No spatial structure locally

Species that exhibit spatially controlled, biogeographic patterns are affected by historical and evolutionary factors and limited dispersal.

A review of two decades of studies of freshwater diatoms at different spatial scales revealed that at the local level, environmental factors (i.e., water pH, conductivity, and major ion concentrations) and trophic status (as reflected by total phosphorus, total nitrogen, inorganic nutrients, chlorophyll *a*) were the most important factors in structuring of diatom communities (Soininen 2007). These environmental factors decrease in importance at larger scales, with both local ecological conditions and historical/evolutionary factors being important at intermediate scales, while historical/evolutionary factors predominate at large, continent scales. This review highlights the importance of scale in determining the degree to which biogeography or “everything is everywhere, but the environment selects” control species composition. However, there remains a lot to discover about the biogeography of microbial species.

#### 4.8 SUMMARY

More recent research has shown that microorganisms inhabit almost all habitats on Earth. Aquatic (streams, rivers, lakes, groundwater), atmospheric, and terrestrial (soil, rock, the deep surface) habitats vary in microbial composition depending on a variety of chemical, physical, and biological conditions, including oxygen level, pH, temperature, moisture content, nutrient availability, and light availability. Studies of these varied habitats are moving from “who’s home” to investigations of what controls diversity in a given habitat. This shift has led to a fundamental shift in our knowledge of the marine food web, incorporating key, previously unidentified roles for microorganisms in this food web. Microorganisms in soil habitats have been known to play key roles in nitrogen cycling for many decades, but the complexity of this habitat has allowed continuous new findings to emerge. Despite the commonly held belief that stressors, such as ultraviolet radiation and desiccation, would kill microorganisms in the atmosphere, new research is revealing that microorganisms are transported long distances in atmospheric currents. Nutrients, electron acceptors, and electron donors influence microbial population growth in all habitats, while other abiotic factors, such as seasonality, temperature, and niche space, can contribute to population distributions within these various habitats. One of the most significant debates on microbial distribution centers around the degree to which biogeography controls distributions versus the hypothesis that “everything is everywhere, but the environment selects.” Future research will contribute significantly to our understanding of what controls species diversity within habitats.



## 4.9 DELVING DEEPER: CRITICAL THINKING QUESTIONS

1. What abiotic and biotic factors create microenvironments within habitats?
2. How do lakes, streams, and oceans differ from each other?
3. Why are hot springs considered to be extreme environments?
4. What implication does the extreme nature of hot springs have for microbial species composition?
5. What key roles do microorganisms play in soil ecosystems?
6. Why would microorganisms live in rock as endolithic organisms?
7. To which conditions do microorganisms that live in caves adapt?
8. What implications do these conditions have for the kinds of bacteria and archaea that might live there?
9. How effective are air currents in dispersing microorganisms over long distances?
10. What key resources govern microbial population growth within a habitat?
11. Given that horizontal gene transfer is common and widespread, how valid is the tree of life concept? Do bacteria and archaea exhibit biogeographical patterns or are species ubiquitous and the “environment selects?”

## BIBLIOGRAPHIC MATERIAL

### Further Reading

- Fredrickson JK, Fletcher M (2001), *Subsurface microbiology and biogeochemistry*, New York: Wiley.
- Kirchman DL, Mitchell R (2008), *Microbial Ecology of the Oceans*. New York, NY: Wiley.
- Takacs-Vesbach C, Mitchell K, Jackson-Weaver O, Reysenbach AL (2008), Volcanic calderas delineate biogeographic provinces among Yellowstone thermophiles, *Environ. Microbiol.* **10**:1681–1689.

### Cited References

- Amend JP, Teske A (2005), Expanding frontiers in deep subsurface microbiology, *Palaeogeogr. Palaeoclimatol. Palaeoecol.* **219**:131–155.
- Buckley DH, Schmidt TM (2002), Exploring the biodiversity of soil—a microbial rain forest, in Staley JT, Reysenbach A-L, eds., *Biodiversity of Microbial Life*, New York: Wiley-Liss, pp. 183–208.
- Coyne M (1999), *Soil Microbiology*, Albany, NY: Delmar Publishers.
- Davidson CJ, Surette MG (2008), Individuality in bacteria, *Annu. Rev. Genetics* **42**:253–268.
- de Wit R, Bouvier T (2006), “*Everything is everywhere, but the environment selects*”; what did Baas Becking and Beijerinck really say? *Environ. Microbiol.* **8**:755–758.
- DeLong EF, Karl DM (2005), Genomic perspectives in microbial oceanography, *Nature* **437**:336–342.
- Griebler C, Lueders T (2009), Microbial biodiversity in groundwater ecosystems, *Freshwater Biol.* **54**:649–677.

- Griffin DW (2007), Atmospheric movement of microorganisms in clouds of desert dust and implications for human health, *Clin. Microbiol. Rev.* **20**:459–477.
- Hunt DE, David LA, Gevers D, Preheim SP, Alm EJ, Polz MF (2008), Resource partitioning and sympatric differentiation among closely related bacterioplankton, *Science* **320**:1081–1085.
- Janssen PH (2006), Identifying the dominant soil bacterial taxa in libraries of 16S rRNA and 16S rRNA genes, *Appl. Environ. Microbiol.* **72**:1719–1728.
- Koonin EV, Wolf YI (2008), Genomics of bacteria and archaea: The emerging dynamic view of the prokaryotic world, *Nucleic Acids Res.* **36**:6688–6719.
- Lawrence JG (2002), Gene transfer in bacteria: Speciation without species? *Theor. Popul. Biol.* **61**:449–460.
- Madigan MT, Martinko JM, Dunlap PV, Clark DP (2009), *Brock Biology of Microorganisms*, 12th ed., San Francisco: Pearson Benjamin Cummings.
- Molles Jr MC (2008), *Ecology: Concepts & Applications*, 4th ed., New York: McGraw-Hill.
- O'Malley MA (2007), The nineteenth century roots of “everything is everywhere,” *Nature Rev. Microbiol.* **5**:647–651.
- Pederson K (1997), Microbial life in deep granitic rock, *FEMS Microbiol. Rev.* **20**:399–414.
- Pelczar Jr, MJ, Reid R, Chan ECS (1977), *Microbiology*, 4th ed., New York: McGraw-Hill.
- Pernthaler J, Amann R (2005), Fate of heterotrophic microbes in pelagic habitats: Focus on populations, *Microbiol. Molec. Biol. Rev.* **69**:440–461.
- Pomeroy LR (1974), The ocean's food web, a changing paradigm, *Bioscience* **24**:499–504.
- Ramette A, Tiedje JM (2006), Biogeography: An emerging cornerstone for understanding prokaryotic diversity, ecology, and evolution, *Microbial Ecol.* **53**:197–207.
- Scheu S (2002), The soil food web: structure and perspectives, *Eur. J. Soil Biol.* **38**:11–20.
- Soininen J (2007), Environmental and spatial control of freshwater diatoms—a review, *Diatom Res.* **22**:473–490.
- Spear JR, Walker JJ, McCollom TM, Pace NR (2005), Hydrogen and bioenergetics in the Yellowstone geothermal ecosystem, *Proc. Natl. Acad. Sci. (USA)* **102**:2555–2560.
- Teske AP (2005), The deep subsurface biosphere is alive and well, *Trends Microbiol.* **13**:402–405.
- Torsvik V, Sorheim R, Goksoyr J (1996), Total bacterial diversity in soil and sediment communities—A review, *J. Indust. Microbiol.* **17**:170–178.
- van der Heijden MGA, Bardgett RD, van Straalen NM (2008), The unseen majority: Soil microbes as drivers of plant diversity and productivity in terrestrial ecosystems, *Ecol. Lett.* **11**:296–310.
- Walker JJ, Pace NR (2007), Endolithic microbial ecosystems, *Annu. Rev. Microbiol.* **61**:331–347.
- Wilhelm SW, Matteson AR (2008), Freshwater and marine virioplankton: A brief overview of commonalities and differences, *Freshwater Biol.* **53**:1076–1089.

### Internet Sources

- [http://soils.usda.gov/sqi/concepts/soil\\_biology/soil\\_food\\_web.html](http://soils.usda.gov/sqi/concepts/soil_biology/soil_food_web.html)
- <http://serc.carleton.edu/microbelife/marine/about.html>

# THE HOW OF MICROBIAL ECOLOGY STUDIES

## 5.1 CENTRAL THEMES

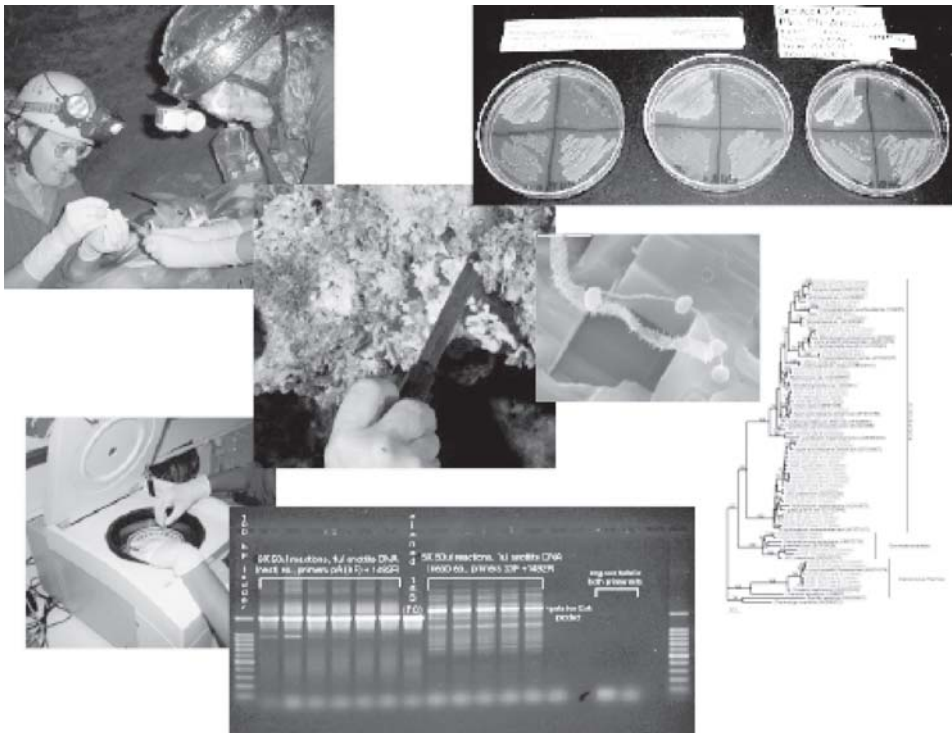
- Appropriate sampling and storage techniques are necessary to obtain a representative characterization of microbial diversity from the natural world.
- Some microbial diversity is revealed only by cultivation, which is also necessary to understand the whole organism and its physiology.
- Microscopy is an important tool in counting the number of microbial cells in an environment, determining cell shapes, and ascertaining the percentage of actively respiring microorganisms present.
- Tools such as fluorescent *in situ* hybridization (FISH) reveal which morphotypes in a community correspond to which phylogenetic groups and allow for quantification.
- Molecular phylogenetic techniques reveal that the diversity of the microbial world dominates the tree of life, and new tools are required to study this immense diversity.
- While molecular phylogeny reveals a startling amount of new diversity, it provides only limited clues to the functions of these newly discovered organisms. New methods such as metagenomics are helping to elucidate these functions.

## 5.2 INTRODUCTION

Microbial ecology requires the ability to measure and assess a variety of parameters about the habitat, the community of organisms present, and the effect of the organisms on the environment. These include, but are not limited to the following:

- Measuring of abiotic parameters
- Counting the number of organisms present
- Visualizing the morphology of organisms and their interactions with their environment
- Culturing of organisms present
- Identifying the nature of the organisms present and their diversity
- Assessing the metabolic pathways employed by the community of organisms
- Measuring and identifying metabolic products and their effects on the habitat

Some of these techniques, such as culturing, have been around for a very long time, while others such as metagenomics, are relatively recent (Figure 5.1). The pace at which



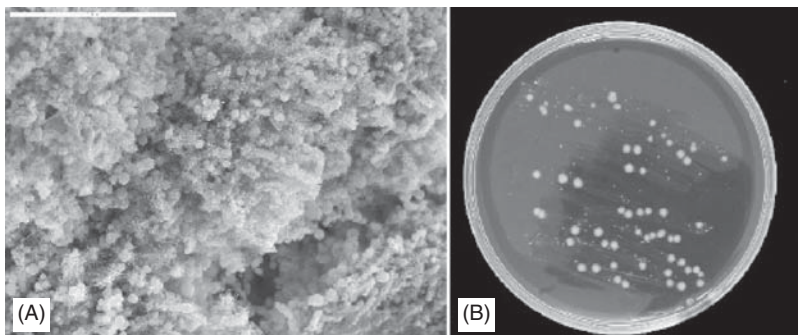
**Figure 5.1.** Many techniques, such as culturing, live/dead staining, abiotic parameter measurement, polymerase chain reaction, phylogenetic tree construction, and DNA extraction, support the study of microbial ecology. (Images courtesy of Kenneth Ingham, Mike Spilde, Sue Barns, and Jessica Snider.)

new techniques are being developed to assess microbial communities has increased substantially since the last millennium, and the genomics revolution promises substantial changes in our understanding of microbial communities. At the same time, old standbys, such as culturing, are key to our understanding of what the organisms actually do in the environment. Researchers have estimated that we are able to culture less than 1% of the microorganisms that are in environmental samples, using standard techniques (Amann et al. 1995). This evolved from the discovery by Staley and Konopka (1985), who realized that what we could visualize with a microscope, from a stained, environmental sample, was very different from what could be grown from that same environmental sample on standard media. This became known as the “great plate count anomaly” (Figure 5.2).

During the same time period, Carl Woese utilized the evolutionary information contained in ribosomal genes to construct phylogenetic trees that provided insight into the three-domain system of classifying life [see Section 2.5 and Woese and Fox (1977)]. Over the subsequent decades, our understanding of where life could live and how diverse the environment was grew by leaps and bounds, as we wholeheartedly adopted what was to become known as “culture-independent methods” (Pace et al. 1986) to circumvent the problem of the “great plate count anomaly.” These techniques have fundamentally changed our understanding of microbial diversity and are an important tool in our microbial ecology toolbox.

To address issues of cost and efficiency, new methods have been developed to capture whole-community analysis, such as DNA fingerprinting and hybridization. Community fingerprinting techniques allow a researcher to compare communities or track communities over time in a relatively rapid and inexpensive manner. Hybridization techniques, such as fluorescent *in situ* hybridization (FISH), utilize labeled oligonucleotides to reveal the presence of specific organisms or groups of organisms. Metagenomics, another relatively recent development, provides insights into some of the functionality contained within microbial communities (Logue et al. 2008).

Which technique you use from the wide array of methods that are available, and the new methods coming online, depends on the question that you are asking. This is not a trivial task, but the goal of this chapter is to give you an overview of techniques that are standard tools in the microbial ecology toolbox.



**Figure 5.2.** The number of microorganisms observed with microscopy (A) is substantially larger than that observed when culturing (B) from the same site (image B courtesy of Airidas Dapkevicius).

### 5.3 SAMPLING AND SAMPLE STORAGE

Microbial habitats tend to be heterogeneous in nature and can possess phenomenal diversity, particularly in soils. This diversity can be distributed unevenly throughout the habitat. Additionally, in order to compare different communities statistically, you need to have an adequate number of replicates. Therefore, selection of appropriate sampling methods for obtaining a representative sample of this heterogeneity must be considered. Sample size can be an important facet of the sampling strategy as seen in the study of soil microbial diversity from agricultural soils by Grundmann and Gourbière (1999). Smaller samples of soil were more successful in cultivating more serotypes of *Nitrobacter* present in the soils. The authors reason that the competition in larger samples is higher and therefore only the dominant serotypes succeeded in growing in the cultures. The small sample size that appeared to be most successful in isolating the serotypes was a volume of  $0.13 \times 10^3 \text{ mm}^3$ . Other studies reviewed by Grundmann and Gourbière (1999) support the idea of smaller samples that may limit species interactions, and the authors suggest the collection of a large number of smaller samples.

When we examine the effect of sampling strategy on culture-independent methods, the picture is a bit different and can depend on the type of soil, for example. Ranjard et al. (2003) suggest that the heterogeneous distribution of soil microorganisms may be important in determining sample size. Fungi tend to occur in the macropores and between soil aggregates, while bacteria often occur within the micropores of the aggregates, possibly influencing which species are retrieved in samples of different sizes. The studies by Ranjard et al. (2003) revealed that sample size for bacteria is not critically important in sampling the full diversity, but that sample size is critical in fungal studies. Their findings support the protocol of taking smaller samples ( $<1 \text{ g}$ ) when attempting to determine fungal species richness and larger samples ( $\geq 1 \text{ g}$ ) when comparing the structure of communities using fingerprinting methods. Larger samples appear to mask some of the more minor members of the community.

Another important aspect of the sampling strategy is how you store and transport the samples for DNA extraction from the sampling site. DNA can be degraded by microorganisms present in the sample, chemicals, enzymes, or other factors. Having lugged 40 lb of dry ice through a cave, one of the authors would suggest considering your sample preservation strategy carefully. There are storage containers for liquid nitrogen that can be used in the field, but these are bulky and difficult to transport by air. Several storage media have been utilized to stabilize DNA until samples can be frozen before extraction. Giovannoni et al. (1990) have utilized a sucrose lysis buffer that lyses the cell and stabilizes the DNA. This buffer can be applied in the field for immediate preservation of the DNA. The temperature at which samples are kept is another important consideration. Katsoulis and colleagues (2005) studied bacterial recovery from samples that were processed immediately versus those that were either stored at room temperature or frozen. Their results suggest that for some bacteria studied, the recovery rate is much greater for those samples processed immediately rather than stored.

What strategy is best may also depend on the microorganisms being studied and the habitats from which they were sampled. Consider experimenting with different sampling and storage regimes to determine what is best for a given experiment.

## 5.4 MICROSCOPY

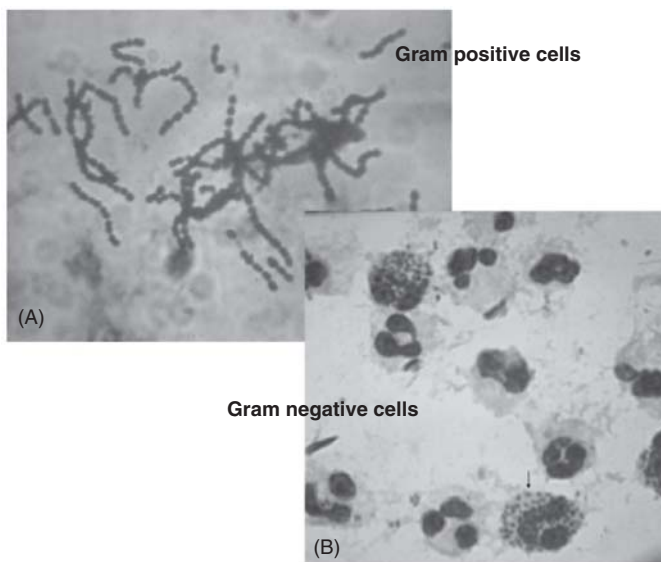
A wide variety of microscopy techniques is available to enhance the study of microbial ecology. These range from the more traditional light microscopy using a compound light microscope at relatively low magnification to electron microscopes that allow for the imaging of cell surfaces or cellular internal structures at much high magnification. Microscopy allows microbial ecologists to count the number of organisms present in an environment, determine how many are metabolically active, visualize morphologies associated with environmental features, and determine the interactions between microorganisms and mineral surfaces. These methodologies will be explored in the next sections.

### 5.4.1 Gram Stains

When working with bacteria, one of the most basic stains used is the *Gram stain* [named after Hans C. J. Gram (1853–1938), Danish physician], which allows us to divide bacteria into those that are Gram-negative and those that are Gram-positive on the basis of their cell wall characteristics. Gram-positive cells stain a purple coloration, while Gram-negative cells stain a pink coloration (Figure 5.3). Gram stain is an example of a differential stain and is one of the most widely used stains in microbiology.

### 5.4.2 Direct Count Procedures

To describe the microbial community of a particular environment, we need to be able to count the number of cells and measure their biomass and activity. Basic microscopy counting of microorganisms, such as described by Madigan et al. (2009), allows one to assess the *total cell count*. There are standards suggesting that a minimum of 20 fields be counted.



**Figure 5.3.** (A) Gram-positive stain of *Streptococcus* sp; (B) arrow points to a Gram-negative bacterium in the cytoplasm of a phagocytic white cell. See insert for color representation.

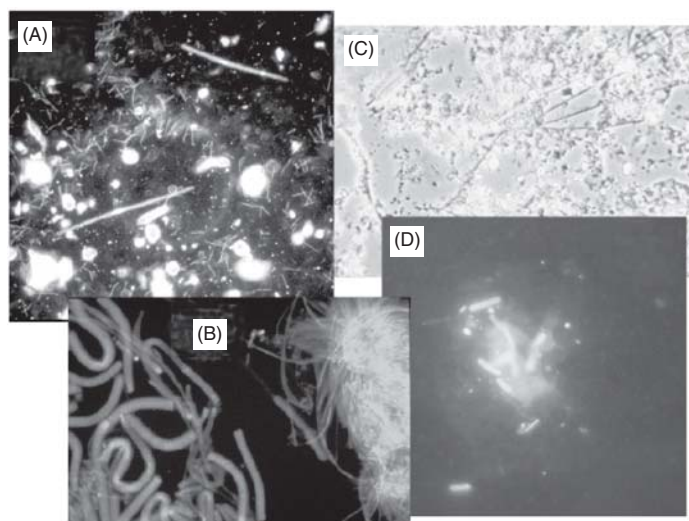


If few organisms are present in any given field, it is necessary to count additional fields in order to achieve adequate results for statistical analysis. To enhance the visibility of cells, various stains and fluorescent dyes such as 4',6-diamidino-2-phenylindole-dihydrochloride (DAPI) or acridine orange, which bind to nucleic acids or other constituents of the cell, are used [see Figure 5.4 and Bölker et al. (2002)]. These dyes have been used extensively with bacteria and to a lesser extent with fungi and protozoa. 5-(4,6-Dichlorotriazin-2-yl)aminofluorescein (DTAF) has become more popular because it stains the background, such as soil particles, much less than do other stains (e.g., acridine orange); however, there are other issues with this and other fluorescent stains, which Bölker et al. (2002) cover in their review. Such staining of soils and other background particles, plus the small size of some bacteria, can render counting of cell morphologies difficult and inaccurate. SYBR Green I stain has even been used to count viruses. Total cell counts do not allow for the differentiation of live cells from dead cells (Section 5.4.3).

Another method for counting microorganisms present involves culturing organisms from the environment. A fixed amount of inoculum is plated onto an appropriate medium, and the number of colonies that form [colony-forming units (CFU)] is termed the *plate count*. A major problem with plate counts is the inability to grow all the organisms present from the environment on any one or even many media. Additionally, faster-growing organisms may outperform slower growing organisms, making this an inaccurate counting mechanism. Finally, many organisms in oligotrophic environments exist in a viable, but nonculturable, state, or are extremely small ( $< 0.5 \mu\text{m}$ ), making them difficult to count by some means (Bölker et al. 2002).

### 5.4.3 Determining Actively Respiring Cells

There are several methods for determining the fraction of the population of microbial cells that are actively respiring. One of these is the incubation of an environmental



**Figure 5.4.** Microbial cells can be visualized for counting using a variety of microscopic techniques, including phase contrast and epifluorescent microscopy using acridine orange (D) and DAPI (B). (4,6-diamidino-2-phenylindole-2HCl). (Photomicrograph (B) courtesy of Louise Hose; other photomicrographs courtesy of Diana Northup.) See insert for color representation.

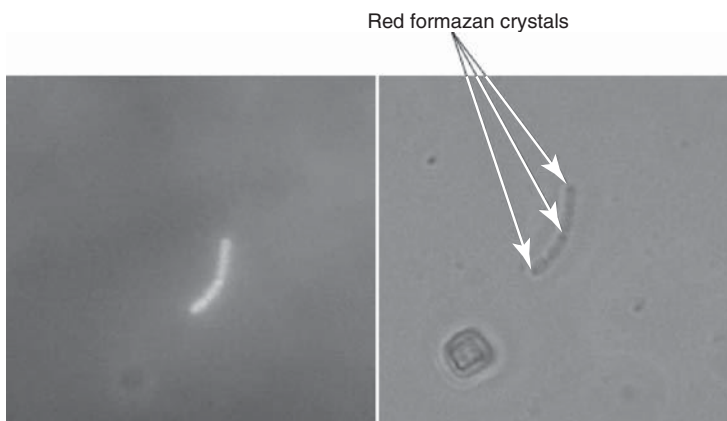
sample with the metabolic dye, *p*-iodonitrotetrazolium (INT). Cells that are metabolically active will reduce the INT to formazan, which is then deposited within the cell. Counterstaining with a DNA dye such as acridine orange allows for easier visualization of cells among sediments, and the formazan can be visualized with phase contrast microscopy (Figure 5.5). Alternative ways of measuring actively respiring cells include the use of the dye 5-cyano-2,3-ditolyltetrazolium chloride (CTC), although it has been argued that CTC detects viability and not necessarily activity (Creach et al. 2003). Commercially available kits, such as the LIVE/DEAD™ BacLight® viability kit, are also used to determine viable cells, but have been difficult to use *in situ* in natural environments (Pascaud et al. 2009).

#### 5.4.4 Fluorescent *in situ* Hybridization (FISH)

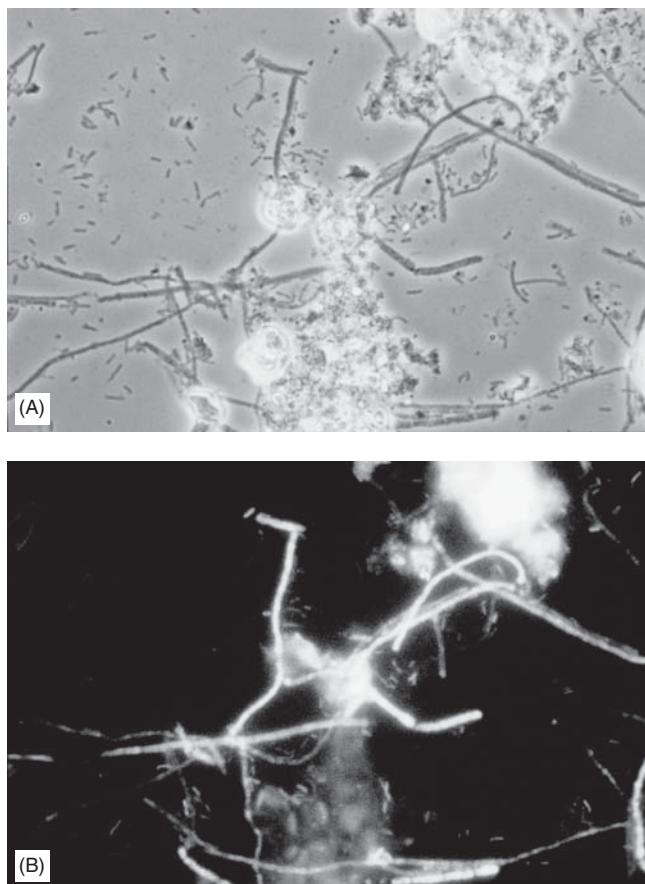
Fluorescent *in situ* hybridization (FISH) allows for the quantification and identification of microorganisms in complex habitats. Dating from the late 1980s, FISH uses a fluorescent oligonucleotide probe that hybridizes to the ribosomal RNA and can be designed to hybridize to specific species or, broadly, to a whole domain. In Figure 5.6, filaments and rods from a stream (visualized with phase contrast in image A) have been hybridized with a probe for Bacteria. The fact that only the long filaments “light up” in image B suggests that the filaments are bacterial, while the rods and shorter filaments probably belong to the domain Archaea.

The FISH method involves a series of relatively simple steps (Figure 5.7), which include (Amann and Fuchs 2008):

1. Fixation of cells with formaldehyde or ethanol
2. Permeabilization of the cell membranes to the probe
3. Hybridization of fluorescently labeled oligonucleotide probes to ribosomes within target cells
4. Removal of excess probe by washing
5. Visualization and quantification using epifluorescent microscopy or flow cytometry



**Figure 5.5.** By incubating environmental samples with *p*-iodonitrotetrazolium (INT) dye, followed by counterstaining with acridine orange, it is possible to assess respiratory activity. Cells with red formazan crystals (arrows) in their interior are metabolically active. (Photomicrographs provided by Diana Northup and Rachel Schelble.) See insert for color representation.

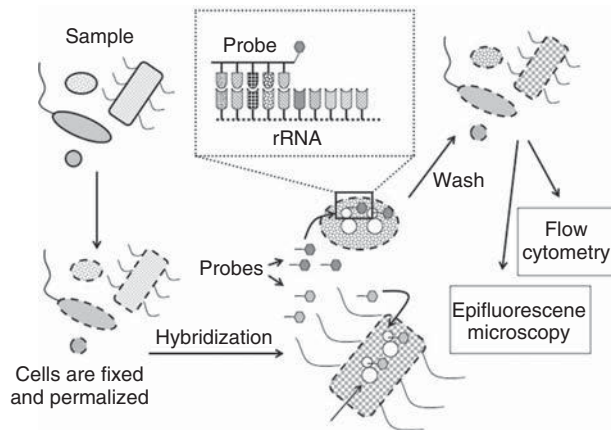


**Figure 5.6.** (A) Phase contrast image of bacteria and archaea; (B) the same field of view visualized with epifluorescence to show microorganisms that hybridized with probes for the Bacteria domain. (Photomicrographs provided by Diana Northup and Anna-Louise Reysenbach.) See insert for color representation.

An online database, called *probeBase*, of rRNA-targeted oligonucleotide probes has been developed to facilitate the selection of appropriate probes. Probe sequences for major groups are listed in Amann and Fuchs (2008), which also includes a discussion of how well the various group-specific probes work. Which probe is appropriate depends on what one is trying to ascertain; in new environments, domain-level probes may be useful to get a broad idea of who's present, while well-characterized environments would benefit from genus- or species-level probes.

An enhanced version of FISH, called *catalyzed reported deposition–fluorescence in situ hybridization* (CARD–FISH), gives a stronger signal by hybridizing one oligonucleotide with a crosslinked horseradish peroxidase label, which, in turn, radicalizes tyramide molecules, which bind to the cell once activated. These and other enhancements have been reviewed by Amann and Fuchs (2008).

The FISH method provides an important tool for quantifying different phylogenetic groups in environmental samples and for identifying morphologies of interest in complex environmental samples. However, FISH is not without its challenges, which include



**Figure 5.7.** Illustrated guide to the steps involved in FISH [modified from Amann and Fuchs (2008)].

cell membranes that do not permeabilize well, cells of interest with low numbers of ribosomes—which translate to poor signals, and problems in binding to the probes. As these problems are worked out, this technique will become even more valuable in microbial ecology.

#### 5.4.5 Electron Microscopy

While light microscopes utilize photons for imaging, electron microscopes use electrons. Scanning electron microscopy (SEM) (Figure 5.8) is used to visualize surface features of microorganisms or their interactions with their habitat (Figure 5.9). SEM images not only allow us to better understand microbial interactions with each other and their environments, but the beauty of the images enchants audiences of scientists and the public as well. Small samples of environmental microbial mats and seemingly bare rock surfaces can be transformed into jungles of microorganisms with the high magnification provided by SEM. For visualization, samples are coated (Figure 5.10) with a heavy metal, such as gold or palladium (or a combination of these two) to enhance imaging.

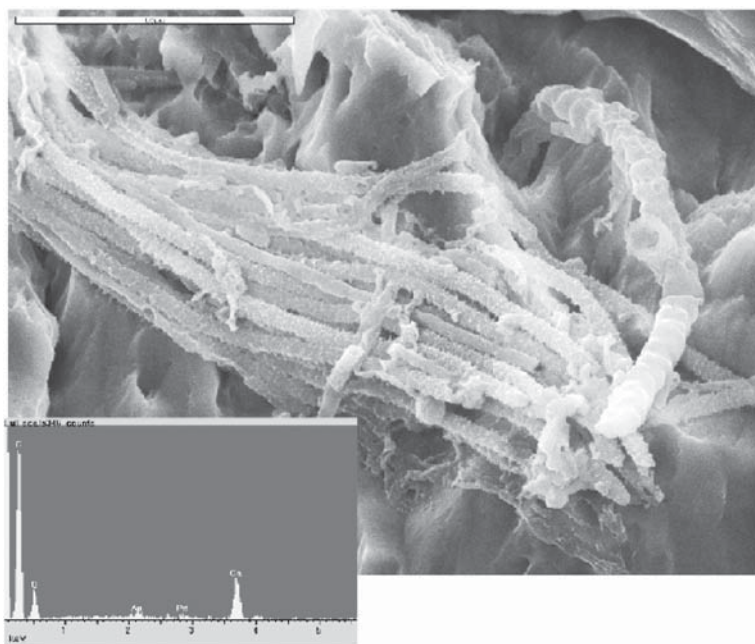
Transmission electron microscopy (TEM), on the other hand, allows for the imaging of internal cellular structures (Figure 5.11). TEM imaging requires the thin sectioning of samples because electrons do not penetrate very far into the sample. To improve contrast, samples for TEM imaging are stained with substances such as permanganate or osmic acid. TEM has been very useful in studies of microbe–mineral interactions (geomicrobiology) because it allows scientists to examine where minerals are deposited in relation to cells. Advances in high-resolution TEM are making it possible to accomplish feats such as the visualization of the *Yersinia* injectisome needle, a pseudopilus that allows the bacterium to deliver virulence proteins into host cells (Müller et al. 2008).

### 5.5 CULTIVATION OF MICROORGANISMS

Cultivation (Figure 5.12) is one of the oldest tools in microbiology, dating back to Koch’s development of the concept of pure cultures. Using his experiments with solid

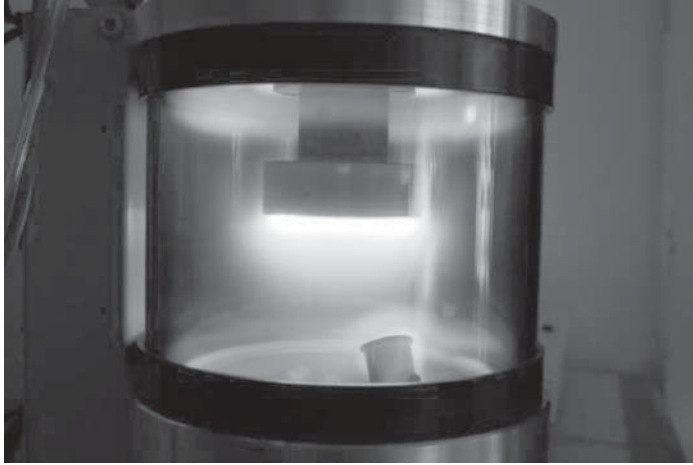


**Figure 5.8.** Scanning electron microscope equipped with X-ray dispersive spectroscopy. (Image courtesy of Kenneth Ingham.)

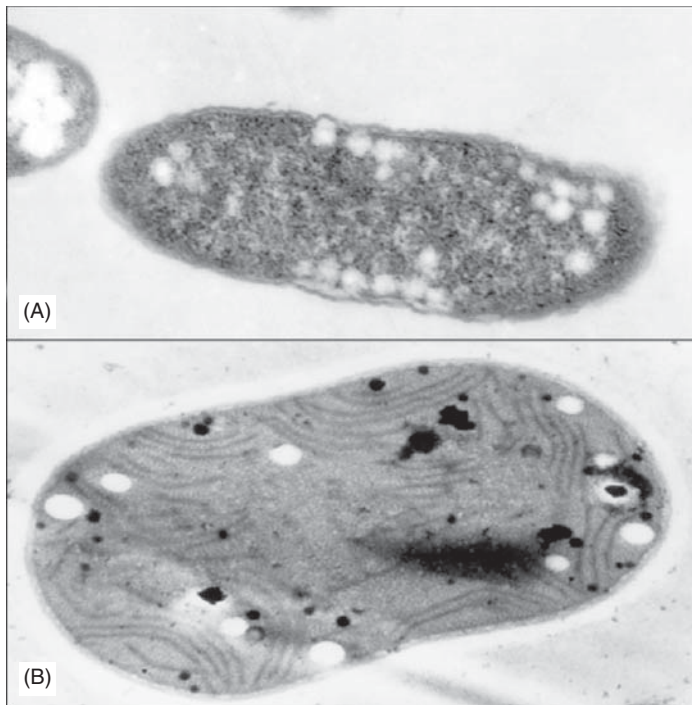


**Figure 5.9.** Filamentous bacteria associated with calcium carbonate formations in caves are visualized with scanning electron microscopy (SEM). The lower image shows an elemental analysis of the filaments, documenting a larger peak for carbon than would be expected if only calcium carbonate were present. Also note the filament emerging from a hole in the rock in the upper right of the SEM image. (Images courtesy of Michael Spilde and Leslie Melim.)

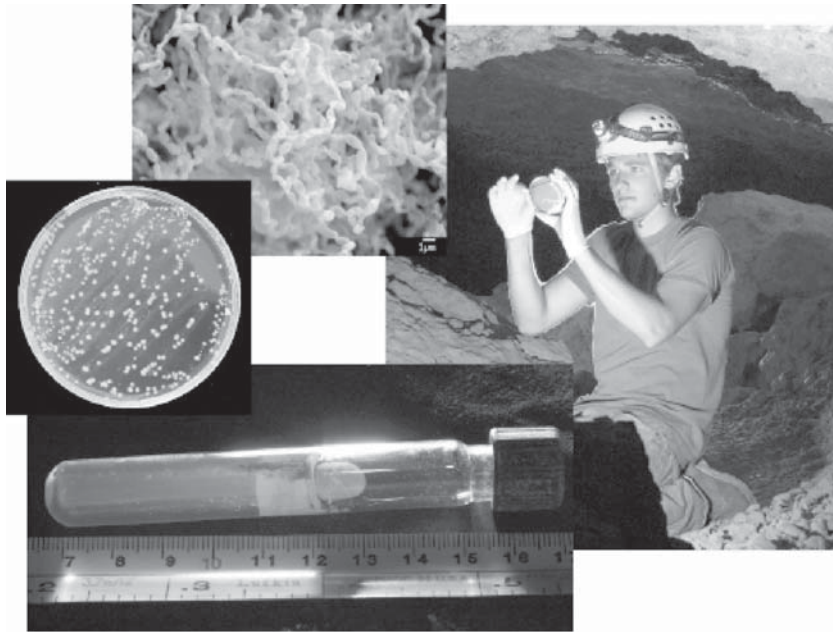




**Figure 5.10.** Sample being coated with gold/palladium for scanning electron microscopy (image courtesy of Jessica Snider). See insert for color representation.



**Figure 5.11.** Observation of bacteria by transmission electron microscopy (TEM). Thin sections of bacteria were stained with phosphotungstic acid and lead citrate. (A) At the surface of the Gram-negative sulfate-reducing bacterium are the outer membrane and the plasma membrane. Polyglucose granules are distributed along the surface of the cell, and these internal transparent structures have a diffuse border. (B) Unidentified bacterial isolate has a Gram-negative type of cell wall. The bacterium has internal membranes, granules of poly( $\beta$ -hydroxybutyrate) (transparent structures), and polyphosphate granules (dark spherical structures). Several other dark internal granules of unknown composition are also present inside the cell. (Photograph by Larry Barton.)



**Figure 5.12.** Culturing microorganisms from natural environments. (Photos courtesy of Kenneth Ingham and Michael Spilde.)

media, including the incorporation of agar as a solidifying agent (developed by Walter Hesse), Koch was able to grow the first pure cultures of *Bacillus anthracis* and then *Mycobacterium tuberculosis* in 1876 and 1882, respectively (Logue et al. 2008). The use of cultivation in microbial ecology often has been discarded in favor of using culture-independent techniques that will be described later in this chapter. Several studies in the 1990s proclaimed that less than 1% of environmental organisms were culturable using standard media and conditions [see, e.g., Amann et al. (1995)]. However, Donachie et al. (2007) documented that many organisms are recovered by culturing that are not recovered in culture-independent, nucleic-acid-based techniques. Such differences in microbial diversity recovery may be due to the inherent biases in DNA extraction and polymerase chain reaction (PCR), and the inability to lyse some microbial cells.

The key phrase in the prior statement concerning unculturable organisms is *using standard media and conditions!* Several more recent studies have shown that the use of media and conditions that incorporate nutrients and abiotic factors from an organism's environment greatly enhances the success of the cultivation efforts [reviewed in Leadbetter (2003)]. Our lack of success in culturing many organisms has been due to our inadequate understanding of the organisms' native environment; our failed efforts are somewhat akin to feeding cats, which are obligate carnivores, a vegetarian diet; such a diet, in the long run, leads to death of the organism. Microbial ecology dogma has maintained that "there is no biological redox cycle for phosphorus," yet researchers have found an anaerobic bacterium that uses phosphite as its only electron donor, oxidizing the phosphite to phosphate [also reviewed in Leadbetter (2003)]. Additionally, some organisms are very slow-growing. A colleague once waited 2 years for growth of an environmental organism of interest. Our group also utilizes rock dust from the native substrate in the media, and we allow the cultures to grow in the native environments for days to months.



## Microbial Spotlight

### ANNA-LOUISE REYSENBACH



Anna-Louise explores for new microbes in a cave.—(Photograph courtesy of K. Ingham, copyright 2001.)

“I have a nose for microbes. . .it’s like being a good naturalist. It’s like growing plants—you have to understand what they need.” This well-tuned nose for microbes led Anna-Louise to an exciting new discovery in 2006 (Reysenbach et al. 2006). One of her life goals has been to find and culture a thermoacidophile from deep-sea vents. On a research expedition to the Lau Basin vents in the South Pacific, she noted an interesting rock on the dive, which she proceeded to sample. Analysis of the samples showed the presence of a relative of *Ferroplasma*, a microbe really different from those usually found at deep-sea hydrothermal vents. She went after this organism, trying to get it in culture. They got something even better! “This organism has two protrusions coming out of its forefront. It looks like a little devil. The DHVE2 clade? . . .No, we got the devil thermal blob with two horns!! Got the thing I’ve been looking for for 5 years.” This newly cultivated microorganism is *Aciduliprofundum boonei* and is the first thermoacidophile from vent deposits to be captured in culture. Studies revealed that the organism reduces sulfur or iron and represents 15% of the Archaea at this vent site, making it a potentially important player in iron and sulfur cycling at vents. *Aciduliprofundum boonei* represents the first cultured member of the DHVE2 (deep-sea hydrothermal vent euryarchaeotic 2) lineage—another first. Her curiosity and some first-rate detective and labwork by her team led to several firsts, a *Nature* paper, and a lot of fun discoveries.

This finding is congruent with studies of slow growers reviewed by Leadbetter (2003), who also provides examples of other culturing challenges that have been met.

Another important culturing breakthrough that required a great deal of patience was the cultivation of the widespread, oligotrophic marine Alphaproteobacteria, SAR11, which was named *Pelagibacter ubique*. Giovannoni and Stingl (2007) were able to finally cultivate SAR11 after almost a decade by eliminating faster-growing competitors through dilution-to-extinction techniques, by using very low-nutrient media made from natural seawater, and by allowing sufficient time for growth that was detected at low levels by enhanced, high-throughput screening methods (Giovannoni and Stingl 2007). Our ability to culture other oligotrophs that can grow on 1–15 mg/L of carbon has been enhanced since the 1970s.

Successful culturing efforts of environmental organisms rely on addressing two major challenges: (1) supplying nutrient sources and abiotic conditions of the natural environment in which the desired organisms are growing and (2) preventing the fast-growing organisms from this environment from outperforming the slower-growing organisms from the same environment. Nucleic-acid-based techniques, such as rDNA clone libraries and metagenomics, coupled with a thorough knowledge of the physico-chemical parameters of the environment, can provide important clues to identify potential metabolic pathways employed by the desired organisms.

### 5.5.1 Microbial Respiration

One general, reliable measure of microbial activity is the measurement of either carbon dioxide production or the uptake (consumption) of oxygen as a proxy of microbial respiration, called the *respiration index* (RI). Heterotrophic, aerobic microorganisms oxidize organic compounds, for example, in soils, to produce carbon dioxide, which is often measured using a method that fixes carbon dioxide captured with an alkaline trap. Carbon dioxide, which represents a much lower percentage of the atmosphere than does oxygen, can be more accurately measured. The pH of the sample can pose problems in the accurate measurement of carbon dioxide release. An alternative is the measurement of oxygen uptake using static or dynamic respirometry methods. These measurements have been widely used in the compost industry to establish the stability of compost [reviewed in Gómez et al. (2006)]. In soils, parameters such as temperature, nutrient availability, soil structure, and moisture content can all greatly affect soil respiration (Winding et al. 2005), and pre-conditioning of the soil may be necessary to standardize measurements of respiration.

### 5.5.2 Microbial Biomass

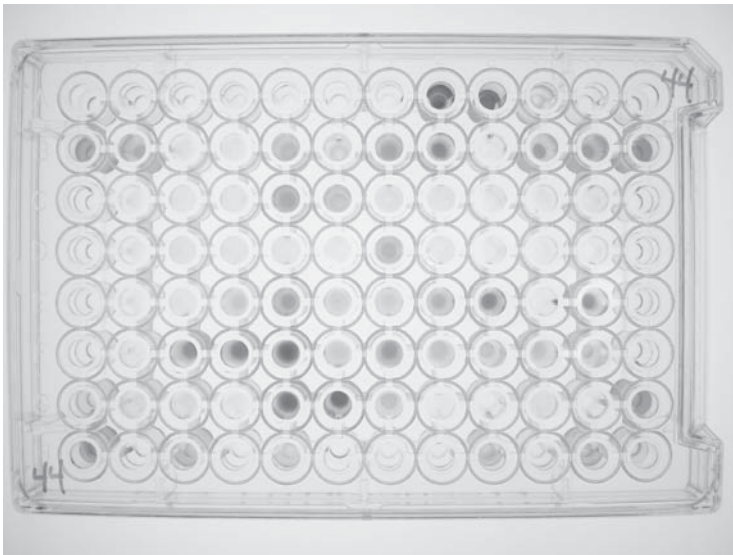
Microbial biomass can be correlated with a number of key ecosystem parameters, such as fertility, decomposition rate, organic matter content, mineralization of nitrogen and soil fertility, structure, and stability in soil ecosystems. Various indirect and direct methods of measuring microbial biomass have been utilized. One of the most commonly used indirect measures is chloroform fumigation, in which the chloroform is utilized to kill the soil microorganisms. This is followed by either extraction of the soil to quantify

the extractable carbon, or by a period of incubation in which researchers measure the carbon dioxide released by germination of microbial spores utilizing the carbon from the newly dead microbial biomass. The addition of a substrate such as glucose, which is easily utilized by some microorganisms, to soils or other habitats, provides an indirect measure of microbial biomass, called *substrate-induced respiration*. After addition of the substrate, researchers measure the change in soil respiration rate and use this measurement to determine the metabolically active portion of soil microbial biomass (Winding et al. 2005). Direct count procedures (Section 5.4.2) can be used with a conversion factor to estimate biomass, although special techniques are needed for some microorganisms, such as fungi, where fungal hyphal length is measured.

### 5.5.3 Measuring Carbon Substrate Utilization

BioLog MicroPlates have been used to determine what carbon substrates microbial species of interest are capable of utilizing. These microplates contain 96 wells, each containing an electron acceptor plus a carbon compound. The well containing a carbon source used by the bacteria would reduce the electron acceptor dye and produce a purple color as seen in Figure 5.13. This system allows for the testing of 95 different carbon substrates, but the usefulness of the system depends on the ability to culture microbial species of interest in liquid media.

Because of their rapid growth and importance in ecosystem processes, the study of microbial community changes can be critical to understanding ecosystems. A community-level application of BioLog allows researchers to assess differences in communities along



**Figure 5.13.** Results of a test of carbon substrate utilization by bacterial species using the GP2 MicroPlate (Hayward, CA); the strength of purple color shows the degree to which a particular carbon source is utilized (image courtesy of Armand Dichosa). See insert for color representation.

temporal and spatial scales (Garland 1997), which they termed “community-level physiological profiling” (CLPP). Different organisms within a community use different carbon sources at different rates, allowing insights into the community structure and functional diversity. This technique has been utilized to assess the effects of different treatments (e.g., nitrogen addition) across time. CLPP involves inoculation of environmental samples into microtiter plate wells that contain redox dyes, such as tetrazolium violet. Because BioLog is based on cultivation, some biases in the responding organisms will exist and the amount of inoculum can affect the results. However, it is an economical tool with reproducible results, which, used in conjunction with other tools such as denaturing gradient gel electrophoresis (DGGE) (Section 5.8.1), can produce valuable results (Xue et al. 2008).

## 5.6 MOLECULAR PHYLOGENETICS

Phylogenetics is the study of relationships among organisms on the basis of evolutionary differences and similarities. Molecular phylogenetics has had an enormous impact on microbial ecology and has greatly expanded our knowledge of organisms present in the natural environment from what was previously known from cultivation efforts. Many of these studies have been based on sequencing of ribosomal genes from DNA extracted from environmental samples. Figure 5.14 shows an example tree of selected 16S SSU (small subunit) sequences from a desert varnish and adjacent rock community. Small subunit ribosomal DNA has been utilized in many of these studies because of the ubiquity of ribosomal DNA and the high degree of conservation within ribosomal genes. Improvements in our ability to extract DNA from difficult samples, including soil samples, and in amplification of genes using polymerase chain reactions have greatly enhanced these studies. At the present time, full-length 16S sequences are still considered necessary for building a phylogenetic tree that accurately represents relationships among organisms. Cheaper and faster sequencing are making it possible to sequence thousands of organisms from an environment. The more traditional Sanger sequencing (Madigan et al. 2009) is being supplemented and even, in some cases, replaced by the newer 454 pyrosequencing, which produces large numbers of shorter sequences. Efforts are underway to increase the yield and length of sequences from 454 pyrosequencing (Tringe and Hugenholtz 2008).

In order to analyze these large numbers of sequences from community studies, new software has been developed that groups sequences into operational taxonomic units (OTUs). An example of such software is DOTUR (Schloss and Handelsman 2005), which groups OTUs according to similarities between sequences, and produces rarefaction curves that allow one to assess the degree to which they have adequately sampled the diversity of a given community. Grouping sequences into OTUs allows for more rapid selection of representative sequences to be placed in phylogenetic trees. To effectively analyze differences between communities, statistical software is needed. One useful package is UniFrac, which compares 16S sequences from multiple samples within the framework of a phylogenetic tree. The program identifies the portion of unique branch lengths within the phylogenetic tree and then performs a principal-coordinate analysis to determine what environmental parameters could be responsible for observed differences.

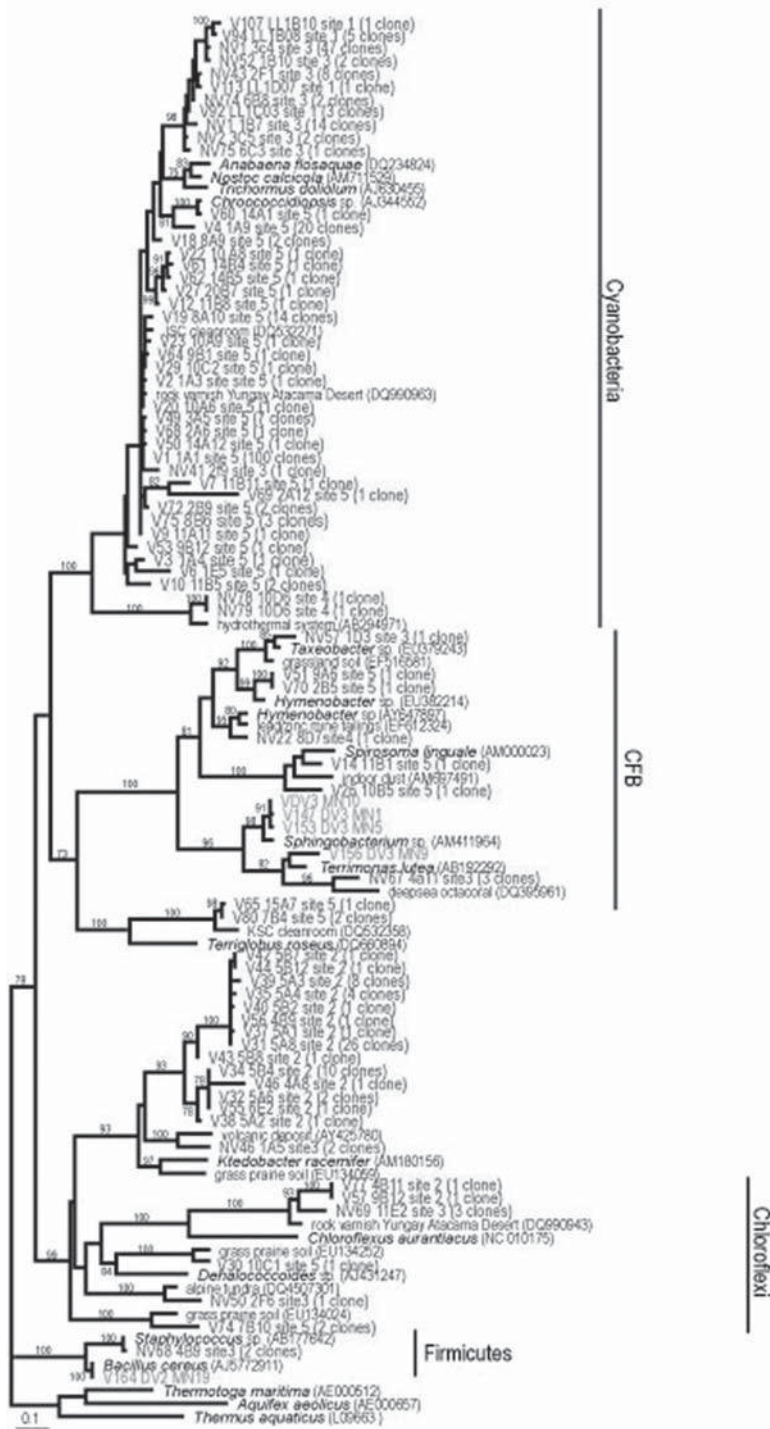


Figure 5.14. Molecular phylogenetic analyses of 16S rDNA sequences produce a phylogenetic tree that enables one to see evolutionary relationships among environmental sequences and cultured relatives. (Phylogenetic tree courtesy of Jessica Snider.) See insert for color representation.

Such tools enable microbial ecologists to move beyond descriptive studies of community diversity to asking questions about what drives diversity and other interesting questions.

## 5.7 CULTURING VERSUS MOLECULAR TECHNIQUES: COMPARISONS FROM SOIL STUDIES

A gram of soil may contain  $10^{10}$  microorganisms of over 4000 different species from several different bacterial divisions (Torsvik et al. 1990). When Buckley and Schmidt (2002) evaluated the published reports of bacteria detected in soils from various regions of the world, they observed that the bacterial groups detected in soil may vary with the specific technique used. As presented in Table 5.1, the Proteobacteria division contains the most commonly detected bacterial groups when rDNA, rRNA, FISH, or traditional plate count techniques are used. Even though the Acidobacteria and Verrucomicrobia are not well characterized, they are important soil bacteria of significant abundance as established by using the rDNA detection method. Members of the Proteobacteria are highly diverse and include the nitrogen-fixing rhizobia, methylotrophs, nitrifiers, sulfate reducers, iron reducers, and fluorescent pseudomonads, which utilize a wide range of carbon compounds. Cytophagales are important for decomposition of plant matter because of their production of cellulase and chitinase. The Firmicutes are Gram-positive bacteria with a low guanine + cytosine (G + C) ratio and include the spore-forming bacteria, lactic acid bacteria, and the clostridia. The Actinobacteria are the Gram-positive bacteria with a high G + C ratio, including the metabolically diverse filamentous actinomycetes. There is frequently a low detection of the Firmicutes and Actinobacteria in soil using rDNA because of the difficulty in extracting DNA from these resilient bacteria. Planctomycetes are aquatic bacteria that may be present in soil; however, their role in soil remains unclear. Although not included in the table, nonthermophilic members of the Crenarchaeota containing at least four phylogenetic clusters are present in soil, and these archaea comprise about 1% of 16S rRNA in soil (Buckley et al. 1998).

TABLE 5.1. Mean Values of Relative Abundance of Bacterial Physiological Groups Detected in Soil Communities

Phylogenetic Group	16S rDNA	rRNA	FISH	Colony Count
Alphaproteobacteria	18	25	13	12
Betaproteobacteria	5	2	1	12
Gammaproteobacteria	3	3	<1	10
Deltaproteobacteria	4	na <sup>a</sup>	4	0
Acidobacteria	19	4	na	0
Actinobacteria	7	11	na	15
Cytophagales	7	<1	<1	10
Firmicutes	6	na	na	41
Planctomycetes	3	7	5	0
Verrucomicrobia	11	2	na	0

<sup>a</sup>Data not available.

Source: Modified from Buckley and Schmidt (2002).



## 5.8 COMMUNITY FINGERPRINTING METHODS

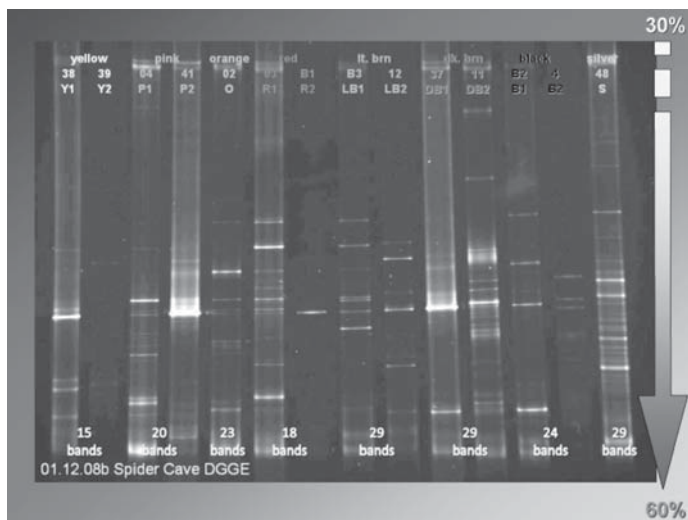
### 5.8.1 Denaturing Gradient Gel Electrophoresis

In contrast to 16S rRNA gene clone library genetic analysis, community fingerprinting techniques such as denaturing gradient gel electrophoresis (DGGE) allow for a more rapid capture of the overall diversity of a given community in a given time and space. DNA strands are separated by their sequence composition in DGGE along a linear gradient of urea and formamide (Figure 5.15).

## 5.9 METAGENOMICS: A NEW TOOL FOR ANSWERING COMMUNITY ECOLOGY QUESTIONS

We have progressed greatly in the last few decades in analyzing what microorganisms are present in the environment using culture-independent (see Section 5.6) methods, but we have lacked an overall understanding of the microorganisms and their roles in a given habitat or community. A new method, metagenomics, fills this gap. *Metagenomics* is the analysis of an assemblage or community of microorganisms, such as microbial populations in a lake, using culture-independent methods to analyze the entire genome of all population members to shed light on the nature and function of the microorganisms present (Riesenfeld et al. 2004). In essence, metagenomics samples all the genes present in a given environment instead of just ribosomal genes.

Metagenomics starts (see Figure 5.16) with the extraction of DNA from an environmental sample, followed by cloning of the DNA into a vector that is transformed into



**Figure 5.15.** Denaturing gradient gel electrophoresis (DGGE) allows for comparison of different microbial communities, such as the bacterial ferromanganese deposits seen here. Each band within a lane putatively represents one phylotype within a community and brighter bands represent a greater presence of that phylotype. (Image courtesy of Armand Dichosa.)



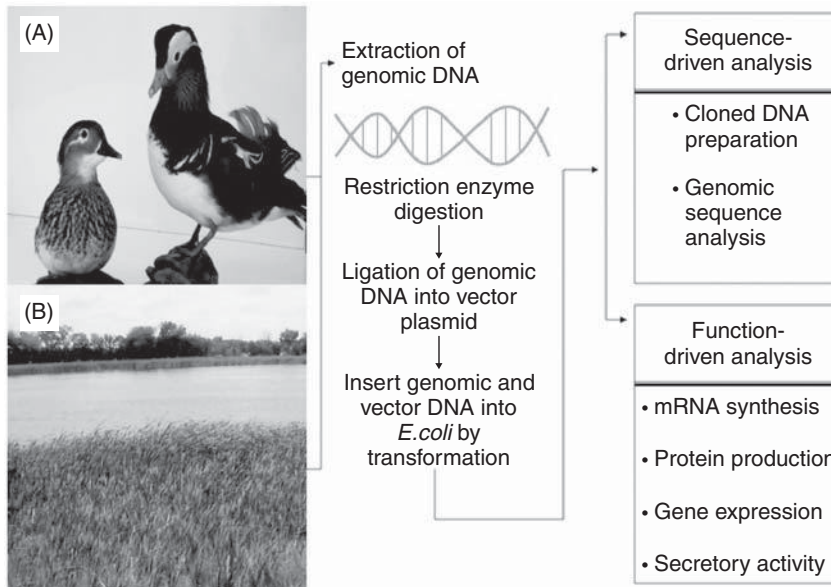


Figure 5.16. Environmental samples can be screened using metagenomics [modified from Handelsman (2004)].

a host bacterium, such as *E. coli*. Subsequent analysis can pursue a phylogenetic or a functional approach. Clones can be screened for a *phylogenetic anchor*, such as 16S rRNA, one of the highly conserved genes. Other studies take the approach of screening for a functional activity, such as a specific enzyme activity. Finally, some metagenomic libraries are sequenced randomly; when genes of interest are located, the flanking regions are sequenced to identify phylogenetic anchors that identify the organism from which the gene of interest came. The latter approach links phylogeny and function and has led to some surprising insights into what functional genes are abundant in nature. All the approaches depend on a culture-independent methodology and thus avoid the large biases of the past when we examined the natural world through the lens of culture-based studies.

## 5.10 ENVIRONMENTAL PROTEOMICS

The production of proteins by bacteria under specific growth conditions can be assessed by identification of individual proteins or by detection of mRNA (messenger RNA) that results from the expression of individual genes. By transcription analysis, mRNA extracted from cells is matched to DNA segments of that organism resulting in the measurement of the “transcriptome.” By comparing the transcription results from DNA microarray-based measurements of a test culture exposed to a given chemical to a control without the chemical addition, a researcher can assess gene regulation. Examples of global transcriptional response by pure cultures of bacteria are given in Table 5.2. Transcription analysis of environmental samples is extremely difficult because very few of the

TABLE 5.2. Case Studies of Metaproteomics, Community Proteomics, and Transcriptomics

System Analyzed	Major Observations
1. Phyllosphere	Community proteogenomic analysis of bacteria on leaves of three different plant species revealed considerable similarity with <i>Methylobacterium</i> and <i>Sphingomonas</i> as dominant organisms; the most abundant proteins of <i>Methylobacterium</i> were associated with methanol utilization while numerous proteins of <i>Sphingomonas</i> were located in outer membranes (Delmotte et al. 2009).
2. Microbial communities in Chesapeake Bay	Proteins in middle Chesapeake bay were distinct from those in the upper and lower Chesapeake Bay; proteins isolated were attributed to <i>Alphaproteobacteria</i> and <i>Bacteroidetes</i> ; however, they were distinct from known proteins (Kan et al. 2005).
3. Biofilm in acid mine drainage (AMD)	The AMD community has low diversity with organisms predominantly from the <i>Leptospirillum</i> groups II and III and from the <i>Ferroplasma</i> types I and II; 42% of the proteins in the biofilm are produced by genes of unknown function; a considerable number of proteins in the biofilm are associated with oxidative stress and protein refolding; new cytochromes for Fe <sup>2+</sup> oxidation were identified (Ram et al. 2005).
4. Bacterial community response to cadmium exposure	Within 15 min of Cd <sup>2+</sup> stress, there was an enhanced production of ATPases, oxidoreductases, transport proteins, and >100 additional unique proteins (Lacerda et al. 2007).
5. Metaproteomics of activated sludge	The presence of polyphosphate accumulating organism <i>Candidatus accumulibacter phosphatis</i> correlated with enhanced biological phosphate removal (EBPR); enzymes linked to the EBPR process included phosphate transport, fatty acid synthesis, glycogen synthesis, glyoxylate and TCA cycles, polyhydroxyalkanoate synthesis, and enzymes of energy generation (Wilmes et al. 2008).
6. Transcriptomics of <i>Bacillus subtilis</i> exposed to peroxides	Using DNA microarray analysis, it was determined that response to hydrogen peroxide or <i>tert</i> -butylperoxide induced three regulons (Helmann et al. (2003).
7. Transcriptomics of the anaerobe <i>Desulfovibrio vulgaris</i> response to oxygen stress	On exposure to O <sub>2</sub> , there was upregulation of the cytochrome c <sub>3</sub> complex and downregulation of the PerR regulon genes (Mukhopadhyay et al. 2007).

bacteria in the environment can be cultivated and there is limited genomic information on organisms in the environment.

In the 1970s, two-dimensional polyacrylamide gel electrophoresis (2D-PAGE) was developed to separate individual proteins from unknown mixtures, and more recently this technique has been important for the development of proteomics. With current proteomic techniques, about 70% of the 2000–2500 proteins present in a bacterial cell can be identified. Initially, biochemists and physiologists applied proteomics to identify unique proteins produced by pure cultures of microorganisms in response to different conditions of cultivation. More recently, there have been significant advances in instrument analysis and the marked reduction in expense for analysis has stimulated several different approaches to characterize proteins in environmental biofilms. The term *metaproteomics*

is used to characterize all of the proteins collectively produced by organisms in an environmental system (Wilmes and Bond 2006), and the goal of metaproteomics is to understand the functional and metabolic contributions of microbial species in a complex environmental community. Currently, several specialized technologies are being developed, including community proteomics and community proteogenomics (Verberkmoes et al. 2009). *Environmental proteomics* is a general designation referring to analysis of all of the proteins present in an environmental sample without regard to biological origin. *Community proteomics* focuses on identifying proteins produced by a specific microbial species, and obviously this is most applicable when only a few species are dominant in the environment. *Community proteogenomics* is an extension of community proteomics to include protein production correlated with species variation and evolutionary development. Assessment of proteins in the environment involves three activities: collection of proteins, analysis of separated peptides, and identification of proteins. Environmental samples may be small (e.g., 10 mL), and if the sample contains minerals or humus, special procedures are used to ensure extraction of all proteins present. Generally the bacteria in the sample are disrupted to release cellular proteins, and in some instances, procedures are used for fractionation of cellular proteins into extracellular proteins, cytoplasmic proteins, and membrane-bound proteins (Banfield et al. 2005). Individual proteins are separated from the sample by either 2D-PAGE or multidimensional liquid chromatography (LC). Isolated proteins are digested by trypsin and the resulting peptides are analyzed by mass spectrometry (MS). Identification of proteins is accomplished by matching the identified amino acid composition of peptides with known proteins using dual (tandem) mass spectrometry (MS/MS). A detailed report including methodology for environmental proteomics has been published by Keller and Hettich (2009). There is considerable interest in developing rapid processing of protein samples for analysis including development of chip-based methods. As reviewed by Verberkmoes et al. (2009), several communities have been examined by proteome analysis, and results of some of these studies are provided in Table 5.2.

### 5.11 STABLE-ISOTOPE STUDIES

Elements of biological importance have multiple forms of stable isotopes, and these isotopic forms do not change because of radioactive decay. As can be seen from the listing in Table 5.3 of stable isotopes for light elements important in microbial ecology, one isotopic form is dominant for each element. The distribution of isotopic forms of each element varies with the substance measured (e.g., air, water, plants, animals, rocks) and this variation is attributed to thermodynamic and kinetic characteristics reflecting differences in masses of the element. Using carbon as an example, the isotope abundance in a sample is expressed as follows:

$$\delta^{13}\text{C}(\text{‰}) = \left( \frac{{}^{13}\text{C}/{}^{12}\text{C} \text{ ratio}_{\text{sample}}}{{}^{13}\text{C}/{}^{12}\text{C} \text{ ratio}_{\text{standard}}} - 1 \right) \times 1000$$

Since the delta values are small, the multiplication by 1000 produces values that are expressed as parts per thousand ( $\delta$ ). Stable isotope analysis has been used for many years for dating of biological deposits and to assess global nutrient cycles of nitrogen or carbon. Stable isotopes of N, Se, S, and other redox-active elements have been used to

TABLE 5.3. Stable Isotopes of Light Elements Important in Microbial Ecology

Element	Isotope	Average Terrestrial Abundance (%) <sup>a</sup>	Application
Hydrogen	<sup>1</sup> H	99.985	Utilization/production of H <sub>2</sub> and cycling of H <sub>2</sub> O
	<sup>2</sup> H	0.015	
Carbon	<sup>12</sup> C	98.89	Used as a tracer to study food chains and webs, utilization of CO <sub>2</sub> , and to determine which microbes are active participants
	<sup>13</sup> C	1.11	
Nitrogen	<sup>14</sup> N	99.63	Used as a tracer to study food chains, including nitrogen fixation, nitrification, and denitrification
	<sup>15</sup> N	0.37	
Oxygen <sup>b</sup>	<sup>16</sup> O	99.759	Used as a tracer to study food chains and determine whether oxygen in organic molecules is derived from H <sub>2</sub> O or CO <sub>2</sub>
	<sup>17</sup> O	0.037	
	<sup>18</sup> O	0.204	
Sulfur <sup>b</sup>	<sup>32</sup> S	95.00	Used as a tracer to study food chains and distinguish between biotic and abiotic reactions
	<sup>33</sup> S	0.76	
	<sup>34</sup> S	4.22	
	<sup>36</sup> S	0.014	

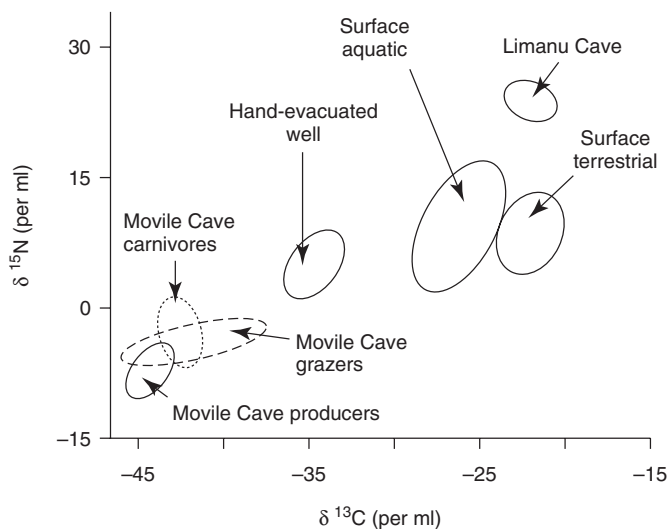
<sup>a</sup>See Ehleringer and Rundel (1989).

<sup>b</sup>Stable isotope ratios commonly used are <sup>18</sup>O/<sup>16</sup>O and <sup>34</sup>S/<sup>32</sup>S.

TABLE 5.4. Biomarkers with Application in Microbial Ecology

Chemical	Organisms Targeted
Specific examples of phospholipid-derived fatty acids	Bacteria, algae, fungi, actinomycetes, methanotrophs, sulfate reducers (each group has a specific fatty acid as a biomarker)
Sterols	Eukaryotes including fungi
Hopanoic acids	Bacteria such as cyanobacteria and methanotrophs
Lipids with ether bonds	Archaea including methanogens
D-Alanine	Most bacteria
Tetrahymanol (a steroid)	Protists including ciliates and flagellates

evaluate chemolithotrophic activities of bacteria. Biological activities can be distinguished from geochemical processes because in general, enzymes preferentially use the stable isotope with the lighter mass. Development of gas chromatography–combustion–isotope ratio mass spectrometry (GC-c-IRMS) has enhanced the use of stable isotope studies in microbial ecology. There are numerous instances where <sup>13</sup>C labeled compounds (CO<sub>2</sub>, acetate, toluene) or algae have been introduced into environments to assess processes functioning in mixed microbial populations [see review by Boschker and Middelburg (2008)]. To determine the microbes participating in a process, Boschker and Middelburg (2008) have suggested the use of biomarkers specific for different microorganisms; see examples in Table 5.4. Coffin and Cifuentes (1993) have proposed the analysis of stable-isotope ratios for carbon and nitrogen in nucleic acids extracted from environmental bacteria to establish the species responsible for a specific process.



**Figure 5.17.** Stable isotope analyses of Movile Cave food web and surrounding areas [modified from Sarbu et al. (1996)].

### 5.11.1 Using Stable Isotopes: Movile Cave Food Web Case Study

An important tool for tracing the flow of energy through communities and ecosystems is stable-isotope ratio analysis. In 1996, a study was published in the journal *Science* by Sarbu and colleagues (1996) that used stable isotopes to establish the base of the food web in a terrestrial cave (Movile Cave) in Romania. This is the first cave system that was documented to be based entirely on microbial chemolithoautotrophy. This intriguing cave was accessed for the first time in 1986; scientists and explorers discovered that portions of the cave were submerged to within a few feet of the ceiling and that airbells contained microbial mats floating on the surface. A wealth of new invertebrate species was discovered, including several that were endemic to the cave. The waters of the cave were rich in  $H_2S$ , and the air pockets in the submerged portions of the cave contained lower amounts of oxygen. Was the  $H_2S$  fueling this ecosystem in total darkness? Early studies showed that microbial lipids in the mats took up radiolabeled [ $^{14}C$ ] bicarbonate, demonstrating chemoautotrophic carbon fixation. To determine the base of this unique cave system, the researchers compared carbon and nitrogen isotopic values from invertebrates sampled from Movile, the surface, and a nearby cave that did not access the sulfidic groundwater. Their analyses clearly demonstrated that the microbial mats serve as the base of this isolated food web (Figure 5.17).

## 5.12 SUMMARY

When one peruses the literature on new methods in microbial ecology, particularly molecular microbial ecology, one gets the impression that the field is moving at a very rapid pace. However, many old standbys, such as cultivation and microscopy, are still very relevant to the field. Methods for sampling and storage are critical for obtaining a representative characterization of microbial diversity from the natural world. Cultivation is

still necessary to reveal some diversity and is also necessary to understand the whole organism and its physiology. Metagenomics, proteomics, and other “omics” also are helping to elucidate functions that microorganisms play in ecosystems. New sequencing technologies are revealing even more of the diversity in the microbial world. As new methodologies come on line, our understanding of the microbial world will increase.

### 5.13 DELVING DEEPER: CRITICAL THINKING QUESTIONS

1. Compare and contrast the techniques that you would use to answer the question of who's home in an environment versus what the microorganisms present are doing functionally.
2. If you have limited funds with which to investigate the microbial community of a given habitat, what techniques would you choose to use?
3. When sampling in soil environments, what size and how many samples should be taken per site in general? What are the dangers in storing the samples improperly?
4. What information does culturing microorganisms give you that genetic sequence data do not?
5. Electron microscopy can be very useful in answering what kinds of questions in microbial ecology?
6. In what kinds of studies is stable isotope analysis particularly useful?

### BIBLIOGRAPHIC SOURCES

#### Further Reading

- Amy PS, Halderman DL, eds. (1997), *The Microbiology of the Terrestrial Deep Subsurface*, Boca Raton, FL: CRC Lewis Press.
- Burlage RS, Atlas R, Stahl D, Geesey G, Sayler G, eds. (1998), *Techniques in Microbial Ecology*, New York: Oxford University Press.
- Fredrickson JK, Fletcher M, eds. (2001), *Subsurface Microbiology and Biogeochemistry*, New York: Wiley-Liss.
- Hurst CJ, Knudsen GR, McInerney MJ, Stetzenbach LD, Walter MV, eds. (1997), *Manual of Environmental Microbiology*, Washington, DC: ASM Press.
- Kemp PF, Sherr BF, Sherr EB, Cole JJ (1993), *Aquatic Microbial Ecology*, Boca Raton, FL: Lewis Publishers.
- Levin MA, Seidler RJ, Rogul M, eds. (1992), *Microbial Ecology Principles, Methods and Applications*, New York: McGraw-Hill.
- Madigan MT, Mrtinko JM, Dunlap PV, Clark DP (2009), *Brock Biology of Microorganisms*, 12th ed., San Francisco: Pearson Benjamin Cummings.
- Munn CB (2004), *Marine Microbiology—Ecology and Applications*, New York: BIOS Scientific Publishers.
- Stewart-Tull DES, Dennis PJ, Godfree AF, eds. (1999), *Aquatic Microbiology*, Oxford, UK: Blackwell Sciences.



## Cited References

- Amann RI, Ludwig W, Schleifer KH (1995), Phylogenetic identification and *in situ* detection of individual microbial cells without cultivation, *Microbiol. Rev.* **59**:143–169.
- Amann R, Fuchs BM (2008), Single-cell identification in microbial communities by improved fluorescence *in situ* hybridization techniques, *Nature Rev. Microbiol.* **6**:339–348.
- Banfield JF, Verberkmoes NC, Hettich RL, Thelen MP (2005), Proteogenomic approaches for the molecular characterization of natural microbial communities, *OMICS–J. Integrative Biol* **9**:301–334.
- Bölter M, Bloem J, Meiners K, Möller R (2002), Enumeration and biovolume determination of microbial cells—a methodological review and recommendations for applications in ecological research, *Biol. Fertil. Soils* **36**:249–259.
- Boschker HTS, Middelburg JJ (2008), Stable isotopes and biomarkers in microbial ecology, *FEMS Microbiol Ecol.* **40**:85–95.
- Buckley DH, Graber JR, Schmidt TM (1998), Phylogenetic analysis of nonthermophilic members of the kingdom Crenarchaeota and their diversity and abundance in soils, *Appl. Environ. Microbiol.* **64**:4333–4339.
- Buckley DH, Schmidt TM (2002), Exploring the biodiversity of soil—A microbial rain forest, in Staley JT, Reysenbach A-L, eds., *Biodiversity of Microbial Life*, New York: Wiley-Liss, pp. 183–234.
- Coffin RB, Cifuentes LA (1993), Approaches for measuring stable carbon and nitrogen isotopes, in Kemp PF, Sherr BF, Sherr EB, Cole JJ, eds., *Aquatic Microbial Ecology*, Boca Raton, FL: Lewis Publishers, pp. 663–675.
- Creach V, Baudoux AC, Bertru G, Le Rouzic B (2003), Direct estimate of active bacteria: CTC use and limitations, *J. Microbiol. Methods* **52**:19–28.
- Delmotte N, Knief C, Chaffron S, Innerebner G, Roschitzki B, Schlapbach R, von Mering C, Vorholt JA (2009), Community proteogenomics reveals insight into the physiology of phyllosphere bacteria, *Proc. Natl. Acad. Sci. (USA)* **106**:16428–16433.
- Donachie SP, Foster JS, Brown MV (2007), Culture clash: Challenging the dogma of microbial diversity, *Int. Soc. Microbiol Ecol. J.* **1**:97–99.
- Ehleringer JR, Rundel PW (1989), Stable isotopes: History, units and instrumentation, in Rundel RW, Ehleringer JR, Nagy KA, eds., *Stable Isotopes in Ecological Research*, New York: Springer-Verlag, pp. 1–19.
- Garland JL (1997), Analysis and interpretation of community-level physiological profiles in microbial ecology, *FEMS Microbiol. Ecol.* **24**:289–300.
- Giovannoni SJ, DeLong, EF, Schmidt TM, Pace, NR (1990), Tangential flow filtration and preliminary phylogenetic analysis of marine picoplankton, *Appl. Environ. Microbiol.* **56**:2572–2575.
- Giovannoni S, Stingl U (2007), The importance of culturing bacterioplankton in the “omics” age, *Nature Rev. Microbiol.* **5**:820–826.
- Gómez RB, Lima FV, Ferrer AS (2006), The use of respiration indices in the composting process: A review, *Waste Manage. Res.* **24**:37–47.
- Grundmann LG, Gourbière F (1999), A micro-sampling approach to improve the inventory of bacterial diversity in soil, *Appl. Soil Ecol.* **13**:123–126.
- Handelsman J (2004), Metagenomics: application of genomics to uncultured microorganisms, *Microbiol Mol. Biol. Rev.* **68**:669–685.
- Helmann JD, Wu MFW, Gaballa A, Kobel PA, Morshedi MM, Fawcett P, Paddon C (2003), The global transcriptional response of *Bacillus subtilis* to peroxide stress is coordinated by three transcription factors, *J. Bacteriol.* **185**:243–253.

- Kan J, Hanson TE, Ginter JM, Wang K, Chen F (2005), Metaproteomic analysis of Chesapeake Bay microbial communities, *Saline Syst.* **1**:7–19.
- Katsoulis J, Heitz-Mayfield LJR, Weibel M, Hirschi R, Lang NP, Persson GR (2005), Impact of sample storage on detection of periodontal bacteria, *Oral Microbiol. Immunol.* **20**: 128–130.
- Keller M, Hettich R (2009), Environmental proteomics: A paradigm shift in characterizing microbial activities at the molecular level, *Microbiol. Molec. Biol. Rev.* **73**:62–70.
- Lacerda CMR, Choe LH, Reardon KF (2007), Metaproteomic analysis of bacterial community response to cadmium exposure, *J. Proteome Res.* **6**:1145–1152.
- Leadbetter Jr (2003), Cultivation of recalcitrant microbes: Cells are alive, well and revealing their secrets in the 21st century laboratory, *Curr. Opin. Microbiol.* **6**:274–281.
- Logue JB, Bürgmann H, Robinson CT (2008), Progress in the ecological genetics and biodiversity of freshwater bacteria, *Bioscience* **58**:103–113.
- Madigan MT, Mrtinko JM, Dunlap PV, Clark DP (2009), *Brock Biology of Microorganisms*, 12th ed., San Francisco: Pearson Benjamin Cummings.
- Mukhopadhyay A, Redding AM, Joachimiak MP, Arkin AP, Borglin SE, Dehal PS, Chakraborty R, Geller JT, Hazen TC, He Q, Joyner DC, Martin VJJ, Wall JD, Yang ZK, Zhou J, Keasling JD (2007), Cell-wide responses to low-oxygen exposure in *Desulfovibrio vulgaris* Hildenborough, *J. Bacteriol.* **189**:5996–6010.
- Müller SA, Aebi U, Engel A (2008), What transmission electron microscopes can visualize now and in the future, *J. Struct. Biol.* **163**:235–245.
- Nocker A, Burr M, Camper AK (2007), Genotypic microbial community profiling: A critical technical review, *Microbial Ecol.* **54**:276–289.
- Pace NR, Stahl DA, Lane DJ, Olsen GJ (1986), The analysis of natural microbial populations by ribosomal RNA sequences, *Adv. Microbial Ecol.* **9**:1–55.
- Pascaud A, Amellal S, Soulas ML, Soulas G (2009), A fluorescence-based assay for measuring the viable cell concentration of mixed microbial communities in soil, *J. Microbiol. Methods* **76**:81–87.
- Ram RJ, Verberkmoes NC, Thelen MP, Tyson GW, Baker BJ, Blake RC 2nd, Shah M, Hettich RL, Banfield JF (2005), Community proteomics of a natural microbial biofilm, *Science* **308**:1915–1920.
- Ranjard L, Lejon DPH, Mougél C, Schehrer L, Merdinoglu D, Chaussod R (2003), Sampling strategy in molecular microbial ecology: Influence of soil sample size on DNA fingerprinting analysis of fungal and bacterial communities, *Environ. Microbiol.* **5**:1111–1120.
- Reysenbach A-L, Liu Y, Banta AB, Beveridge TJ, Kirshtein JD, Schouten S, Tivey MK, Von Damm KL, Voytek MA (2006), A ubiquitous thermoacidophilic archaeon from deep-sea hydrothermal vents, *Nature* **442**:442–447.
- Riesenfeld CS, Schloss PD, Handelsman J (2004), Metagenomics: Genomic analysis of microbial communities, *Annu. Rev. Genet.* **38**:525–552.
- Sarbu SM, Kane TC, Kinkle BK (1996), A chemoautotrophically based cave ecosystem, *Science* **272**:1953–1955.
- Schloss PD, Handelsman J (2005), Introducing DOTUR, a computer program for defining operational taxonomic units and estimating species richness, *Appl. Environ. Microbiol.* **71**:1501–1506.
- Staley JT, Konopka A (1985), Measurement of *in situ* activities of non-photosynthetic microorganisms in aquatic and terrestrial habitats, *Annu. Rev. Ecol. Syst.* **39**:321–346.
- Torsvik V, Goksoyr J, Daae FL (1990), High diversity in DNA of soil bacteria, *Appl. Environ. Microbiol.* **61**:218–221.

- Tringe SG, Hugenholtz P (2008), A renaissance for the pioneering 16S rRNA gene, *Curr. Opin. Microbiol.* **11**:442–446.
- Verberkmoes NC, Denev VJ, Hettich RL, Banfield JF (2009), Functional analysis of natural microbial consortia using community proteomics, *Nature Microbiol. Rev.* **7**:196–205.
- Wilmes P, Bond PL (2006), Metaproteomics studying functional gene expression in microbial ecosystems, *Trends Microbiol.* **4**:92–97.
- Wilmes P, Wexler M, Bond PL (2008), Metaproteomics provides functional insight into activated sludge wastewater treatment, *PLoS ONE* **3**: e1778.
- Winding A, Hund-Rinke K, Rutgers M (2005), The use of microorganisms in ecological soil classification and assessment concepts, *Ecotoxicol. Environ. Safety* **62**:230–248.
- Woese CR, Fox GE (1977), Phylogenetic structure of the prokaryotic domain: The primary kingdoms, *Proc. Natl. Acad. Sci. (USA)* **74**:5088–5909.
- Xue D, Yao H-Y, Ge D-Y, Huang C-Y (2008), Soil microbial community structure in diverse land use systems: A comparative study using Biolog, DGGE, and PLFA analyses, *Pedosphere* **18**:653–663.

### Internet Sources

- <http://www.phylo.org/> *Cyberinfrastructure for Phylogenetic Research.*
- <http://www.treebase.org/treebase/home.html> *TreeBASE: A Database of Phylogenetic Knowledge.*
- <http://www.microbial-ecology.net/probebase/> *An Online Resource for rRNA-Targeted Oligonucleotide Probes.*
- <http://tolweb.org/tree/> *Tree of Life Web Project*
- [http://www.mothur.org/wiki/Main\\_Page](http://www.mothur.org/wiki/Main_Page) *The Microbiome Ecology Laboratory Statistical Tools for Microbial Ecology.*

---

# 6

---

## MICROBE–MICROBE INTERACTIONS

---

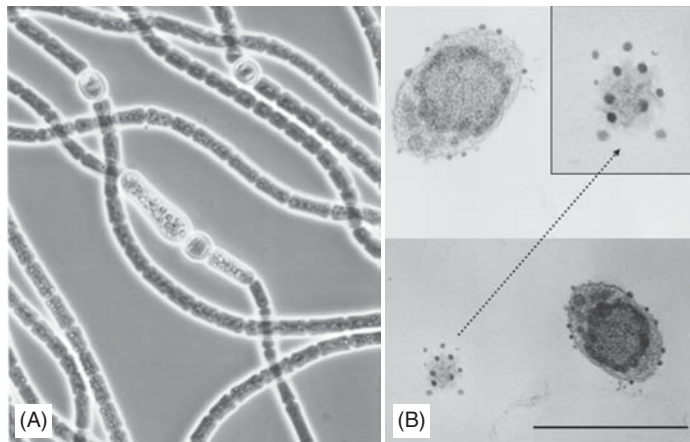
### 6.1 CENTRAL THEMES

- A large number of symbiotic associations occur with cyanobacteria because these organisms can provide carbon- and nitrogen-containing compounds resulting from photosynthesis-driven N<sub>2</sub> and CO<sub>2</sub> fixation.
- Microbial interactions are complex and highly dependent on specific microorganisms involved.
- The specific environment is important in selecting for the dominant cell–cell associations.
- Cell–cell interactions where at least one partner benefits are observed in commensalism, syntrophy, symbiosis and mutualism.
- Cell interactions where one of the partners is subjected to negative effects are evident in competition, parasitism, predation, and antagonism.
- Interactions between microbes of the same species may result in developmental changes including sexual activities.

## 6.2 INTRODUCTION

With the development of microbial communities, the demand for nutrients and space also increases. As a result, there has been a development of different strategies to enable single-cell organisms to persist in an environment. Cell–cell interactions may produce cooperative effects where one or more individuals benefit, or competition between the cells may occur with an adverse effect on one or more species in the environment. While there is a tendency to divide specific activities of cells into categories (e.g., symbiosis, synergism, parasitism), bacteria rarely are limited to a single type of interaction, but their response is transient and influenced by the chemical or physical environment. Several cell types are known for their microbe–microbe interaction, and studies are underway on cells interacting with other microorganisms to produce a highly competitive living system. Examples of microorganisms organisms involved in cell interactions are illustrated in Figure 6.1.

Microorganisms not only respond to the chemical environment but also interact with other microorganisms in their immediate environment. The nature and magnitude of interaction will depend on the types of microorganism present as well as the abundance of the microorganisms and types of sensory systems of the individual organisms. This chapter explores the various types of interaction of a single cell with another single cell (see Table 6.1), and Chapters 7 and 8 address the interactions of microorganisms with plants or animals, respectively. Specific examples of the processes associated with microbe–microbe interaction provide an insight into the unique requirements for interaction (Table 6.2) and the extent to which microorganisms are dependent on another microorganism.



**Figure 6.1.** Prokaryotic cells important in cell–cell interaction: (A) cyanobacteria such as *Anabaena* are important in establishing partnership with other microbial cells (photograph provided by Sue Barns); (B) an unidentified prokaryote found in an aquatic environment has cell surface structures that resemble small protein/lipid units (scale bar 1  $\mu\text{m}$ ) (electron micrograph provided by Sandra Barton).

TABLE 6.1. Types of Interaction between Microorganisms and Hosts

Example	Characteristic	Species A	Species B
Neutralism	No interaction	Not affected	Not affected
Mutualism and symbiosis	Interaction needed to survive in the habitat, and specific species are required	Benefits	Benefits
Protocooperation	Interaction needed to survive in the habitat, but specific species are not required	Benefits	Benefits
Synergism (syntrophism)	Growth of one is improved by another	Benefits	Benefits
Commensalism	One benefits and the other is not harmed or helped	Benefits	Not affect
Competition	Organism in the environment attempts to acquire limiting nutrient	Harmed	Harmed
Parasitism and predation	Host is usually compromised	Benefits	Harmed
Amensalism (antagonism)	Products of one impact another	No effect or benefits	Harmed

TABLE 6.2. Examples of Microbial Interactions

Type	Example
Mutualism and symbiosis	Lichens, mycorrhizae, root nodules; <sup>a</sup> Microorganisms associated with sponges, jellyfish, sea anemones, and corals; <sup>b</sup> Bacteria associated with insects and aphids <sup>b</sup>
Protocooperation	
Synergism (syntrophism)	Interspecies hydrogen transfer—specific species required; cross-feeding of acetate between bacterial species
Commensalism	Nitrification with <i>Nitrosomonas</i> oxidizing ammonia to nitrite and <i>Nitrobacter</i> oxidizing nitrite to nitrate
Competition	Soil bacteria compete with fungi for soluble nutrients
Parasitism and predation	<i>Bdellovibrio</i> sp. and BALO require Gram-negative host for growth; cells of myxobacteria move as wolfpacks and digest other bacteria; protozoa engulf bacteria for nutrients
Amensalism (antagonism)	End products of metabolism inhibit other bacteria; production of antibiotics and bacteriocins; production of viruses active against bacteria and other microorganisms

<sup>a</sup>Covered in Chapter 7.

<sup>b</sup>Covered in Chapter 8.

### 6.3 CLASSIFICATION OF MICROBIAL INTERACTIONS

In addressing microbe–microbe interactions, it is important to determine whether the interaction is between cells of different genera or within the same species. Microbial ecology follows the classification used in general ecology to address the interactions

between microorganisms of different species. In general, interactions between microorganisms of different species promote either robust growth or dominance by a specific microorganism. Interaction between microorganisms of the same species is extremely important in ecology from the perspective of gene transfer within a population and is described in Section 6.8.

### 6.3.1 Neutralism

*Neutralism* occurs when microorganisms have no effect on each other despite their growth in fairly close contact. Neutralism has been demonstrated in the laboratory using dual cultures of bacteria, algae, or protozoa; however, it is difficult to observe cultures in nature with neutralism. It is perhaps possible for neutralism to occur in natural communities if the culture density is low, the nutrient level is high, and each culture has distinct requirements for growth. It has been suggested that neutralism may occur in early colonization of an environment without either harmful or beneficial interactions by the microorganisms introduced.

### 6.3.2 Commensalism

The commensalistic relationship involves two microorganisms where one partner (the commensal) benefits while the other species (the host) is not harmed or helped. Frequently, the relationship between the commensal and the host is casual in that there is no requirement for a specific species. When the commensal is separated from the host, it can grow on its own provided the physical and chemical requirements are favorable. There are several situations under which commensalisms may occur between microorganisms, including the following: (1) conversion of a nonmetabolizable substrate by one species to a compound that is used by a second species, (2) one species releasing vitamins, amino acids and other growth factors that are needed by a second species, (3) one species changing the physicochemical environment, where this activity enables a second species to grow. Commensalism may result from one species destroying toxins, changing the pH of the environment, removing molecular oxygen, or modifying the osmotic pressure of the environment to enable a second microbial species to grow.

Additionally, there are microbial relationships of endocommensalism and exocommensalism. Bacteria growing on the surface of plants are known as *epiphytes*, and protozoa growing on the surface of aquatic animals are called *epizoites*. With respect to microorganisms, cyanobacteria and algal cells are known to secrete nutrients that attract bacteria to their surfaces. While many bacteria growing in the intestine of animals are in a symbiotic relationship, some bacteria do not benefit the animal host, and this is an example of endocommensalism. There are many examples of bacteria growing within protozoan cells, and under most conditions, growth is symbiotic, but in a few instances these dissimilar cells may have an endocommensalistic relationship.

### 6.3.3 Competition

When two or more species use the same nutrients or niches for growth, some of the populations will be compromised. Competition between microbial species may be attributed



to availability of nitrogen source, carbon source, electron donors, electron acceptors, vitamins, light, and water. The *laws of Liebig and Shaford* refer to the limiting of growth resources in macroecology, and these may have applications in microbial populations. As indicated in Box 6.1, a classical example of microbial competition was reported. Competition may either result in exclusion of other species or lead to the establishment of a steady state where multiple species coexist. Competition is seen in aquatic environments where extensive phototrophic activity results in blooms of single species of diatoms or cyanobacteria. In thermophilic springs where chemolithotrophic organisms are selected, the filaments that are present are predominantly of a single bacterial species. When succession of populations occurs, the final species could be considered to result from competition exclusion. Other examples of bacterial exclusion through competition are observed in lactic acid fermentation of foods (e.g., sauerkraut, pickles) and in acid mine wastes where the environment is highly acidic. These examples of exclusionary competition are considered by some to be an example of antagonism.

Interaction between microorganisms for nutrients and space are attributed to both inter- and intrapopulation competition. Competition between species occurs in various environments such as the large intestine of animals, where a single species does not dominate but a mixed population occurs as a result of competition for nutrients. Many laboratory studies have been conducted with microorganisms that are “specialists” or “generalists” on the basis of nutritional capability and the final population can be predicted from equations developed by Monod.

#### 6.3.4 Parasitism

*Parasitism* occurs when one species obtains nutrients from another for the purpose of cell growth. Animal parasites display two types: (1) direct lifecycle that does not require an intermediate host and (2) indirect lifecycle that requires an intermediate host. With microorganisms, the most widespread example of obligate parasitism is with viruses that attack specific cells by a process independent of an intermediate host. Viruses are highly specialized intracellular parasites that generally kill the host cell. All types of microorganisms (i.e., bacteria, fungi, protozoa, algae) have viruses and one role of viruses is to destroy susceptible populations. Danovaro and Serresi (2000) suggest that viruses are responsible for killing about 20% of the ocean’s bacteria. It has been proposed that some viruses predate bacteria and may play an important role in shaping bacterial diversity (Brüssow 2007). Wommack and Colwell (2000) coined the phrase “killing the winning population,” suggesting that bacteriophages prey on the bacterial species that are the most abundant, which keeps the dominant population under control. This phenomenon leads

##### Box 6.1 Competition between Protozoa

In 1934, E. F. Gause coined the phrase “competitive exclusion” to describe the interaction between ciliates. He observed that when he initiated a coculture of *Paramecium caudatum* and *Paramecium aurelia*, only *P. aurelia* was viable after 2 weeks. This observation was supported by the knowledge that the growth rate of *P. aurelia* was greater than that of *P. caudatum* and was not attributed to secretion of toxic compounds by *P. aurelia*.

to greater genetic diversity as the less dominant organisms are not competitively excluded from a habitat by the dominant species. The killing of bacteria by phages with the release of cellular constituents also increases availability of nutrients to other bacterial populations.

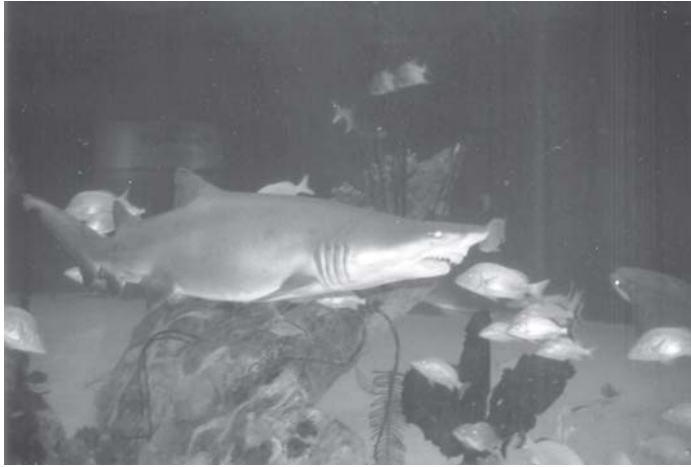
The interaction between a microbial parasite and the host may either kill the host or result in a stable relationship without death to the host. In lysogeny the provirus is carried on the chromosome of the host cell with no apparent harm to the host, and many bacteria harbor proviruses. Pathogenic bacteria or fungi may attack and kill appropriate animals or plant hosts. In other situations parasite aggression may be controlled by the host and a long-term relationship will be produced. With microorganisms as parasites, they may attack the animal host by being either an intracellular or extracellular parasite. Host-dependent bacteria such as *Treponema pallidum*, the causative agent of syphilis, or *Rickettsia rickettsii*, the agent producing Rocky Mountain spotted fever, are examples of obligate parasites that will not grow unless appropriate animal cells are available. Parasites on bacteria, protozoa, or fungi are known and may be either intracellular or extracellular. Several examples of microbial parasitism are discussed in the following sections, and information about bacteria as parasites on animals is found in Chapter 8.

### 6.3.5 Predation

Predatory microorganisms specifically target other microorganisms for materials that enable the predator to survive. In the world of eukaryotes, it is common that the larger animal eats the smaller one (see Figure 6.2); however, with microorganisms the predator may be smaller than the prey. Predatory bacteria (Table 6.3) are of diverse taxonomic affiliation and appear to have evolved at a time when only microorganisms populated Earth. Some have suggested that the evolution of the predator was to satisfy a need for cycling of organic carbon or nitrogen compounds. These unique prokaryotes are ubiquitous in nature where they inhabit soil, aquatic environments, and wastewater. They are either an obligate predator, where they cannot grow outside the prey, or they are facultative, in that they also grow independent of the prey. Members of the predatory bacteria are known as “*Bdellovibrio* and like organisms” (BALO). The BALO members are Gram-negative bacteria that are motile by polar flagella. Three phenotypes are displayed by the BALO: (1) *epibiotic* with growth on the surface of the prey; (2) *periplasmic*, with growth in between the inner and outer membranes of Gram-negative bacteria; and (3) *cytoplasmic*, with growth in the cytoplasm of the prey. Models of these three are given in Figure 6.3.

### 6.3.6 Antagonism (Amensalism)

Competition between species resulting from detrimental products or activities is commonly known as *antagonism*. Competitive exclusion has long been recognized in biology and was a subject addressed by Darwin (1859) in the following statement: “As the species of the same genus usually have. . . much similarity in habits and constitution and always in structure, the struggle will generally be more severe between them, if they come into competition with each other, than between the species of distinct genera.” Antagonistic behavior commonly focuses on exclusion of an organism from growing on a specific site not because space is required for the dominant bacteria but to exclude the other bacterium from utilizing limiting nutrients. Several different processes that account for successful antagonism, and many of these require close contact between bacteria.

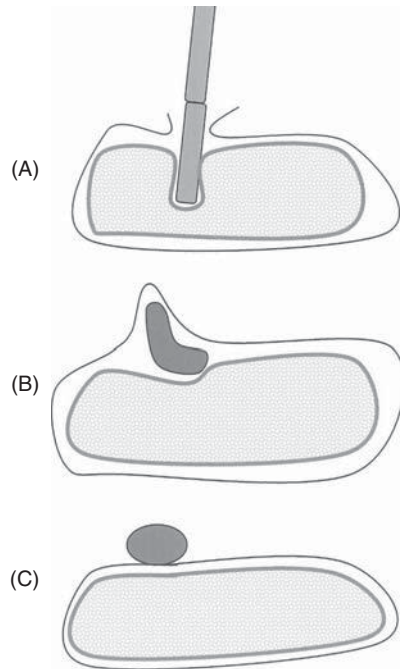


**Figure 6.2.** Sharks are members of the highest level of predators in the oceans; while animal predators are usually larger than their prey, bacterial predators are commonly smaller than their prey (photograph supplied by Larry Barton).

**TABLE 6.3.** Predatory Action of Selected Bacteria

Bacteria	Type of Predation	Strategy
Alphaproteobacteria		
<i>Ensifer adhaerens</i>	Wolfpack	Facultative
<i>Micavibrio</i>	Epibiotic	Obligatory
Betaproteobacteria		
<i>Aristabacter necator</i>	Not established	Facultative
<i>Cuprividus necator</i>	Not established	Facultative
Gammaproteobacteria		
<i>Bdellovibrio</i>	Periplasmic	Obligate
<i>Bacteriovorax</i>	Periplasmic	Obligate
<i>Myxobacter</i>	Wolfpack	Facultative
<i>Peridibacter</i>	Periplasmic	Obligate
Deltaproteobacteria		
<i>Lysobacter</i>	Wolfpack	Facultative

**Antibiotics.** Several species of bacteria and fungi produce chemicals that inhibit the growth of other microorganisms. As a result of this production of antibiotics in nature, susceptible organisms are prevented from becoming dominant in the population and the producers of the antibiotics are given the competitive advantage for growth. In a hallmark investigation Wallhäusser (1951) isolated 123 bacteria and 16 fungi from forest soil and reported that 31% of the bacterial isolated inhibited other bacterial strains, 36% of fungi inhibited other fungi, and 44% of fungi inhibited bacteria. The producers of the antibiotic are not affected because the chemical may inhibit a metabolic step not found in the producer. An example of this is the production of penicillin by fungi; this antibiotic inhibits a type of cell wall found only in bacteria. Another possibility is resistance to the antibiotic produced; and this occurs with *Streptomyces* spp. producing streptomycin. The



**Figure 6.3.** Cell associations: bacteria as predators on other bacteria. Bacterial parasites may be found growing (A) in the cytoplasm, (B) in the periplasm, or (C) on the surface of a bacterial host.

impact of antibiotic production in nature is to greatly reduce the sensitive population but not to totally eradicate it. An example of penicillin-resistant *Staphylococcus* is described in Box 6.2.

As a means of defense against action of antibiotics, bacteria, and to some extent fungi have developed several mechanisms of antibiotic resistance. Resistance to action of antibiotics by bacteria has been attributed to several mechanisms. The principal ones are (1) production of enzymes that degrade the antibiotic, (2) excluded entry of the antibiotic by the production of binding proteins in the cell wall, and (3) transporter systems that rapidly export antibiotics from the cell.

**Bacteriocins.** Many different taxonomic groups of bacteria produce bacteriocins. There is high host specificity for the bacteriocins in that they will kill only strains of bacteria that

#### Box 6.2 Skin Infection of a Hedgehog

Skin infection of the New Zealand hedgehog (Smith and Marples 1964) is attributed to a penicillin-resistant *Staphylococcus*. The normal flora of the hedgehog contains the fungus *Trichophyton* sp., which produces penicillin. Generally, skin infections do not occur because *Staphylococcus* are not resistant to penicillin and the level of penicillin produced by *Trichophyton* sp. is sufficient to inhibit penicillin-sensitive *Staphylococcus*.

are closely related to the producer but do not harm the cell-producing bacteriocins. Most frequently the bacteriocins generate holes in the plasma membrane of susceptible bacteria, and this, of course, results in killing of the bacterial cell. By targeting bacteria of similar physiological and nutritional activities, the bacteriocin producer will exclude susceptible bacteria from the habitat. At one time bacteriocins may have been considered a type of incomplete virus, but they are really more like a highly specialized antibiotic. While bacteriophages have been used to treat flesh-eating bacterial infections, little attention has been given to controlling human pathogens by using bacteriocins. Currently, there is some interest in using bacteriocins to control spoilage of sliced lunch meat.

**Metabolic End Products as Antagonists.** End products of microbial metabolism may inhibit the growth of other microorganisms. As a result of fermentation or modification of chemicals in the environment, bacteria produce chemicals that can serve to inhibit other organisms. This impact is not limited to cell–cell contact but may become dispersed throughout the environment. Extracellular enzymes may also be considered to have antagonistic activity because once the hydrolytic enzymes are released from the microbial cell, the enzymes will digest a suitable substrate even if the polymeric molecule is part of another microbial cell.

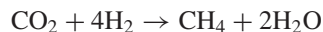
### 6.3.7 Syntrophism

When two species of microorganisms are required for growth on a specific electron donor, their relationship may be designated as *syntrophism*. Syntrophy may enable a second organism to remove end products of metabolism from another organism and thereby enable both organisms to grow at an optimal rate. A second type of syntrophy is observed when a coculture of two organisms is capable of utilizing an electron donor that is not metabolized by either organism alone. Examples of microbial syntrophy are observed under laboratory conditions, and syntrophy also exists in nature.

This relationship was discovered by Meyer Wolin and colleagues when fermentation of propionic acid occurred only when there was a coculture. One bacterium, now called *Syntrophobacter*, produces H<sub>2</sub> according to the following reaction:



Under standard conditions, this fermentation is thermodynamically unfavorable when H<sub>2</sub> accumulates. However, the oxidation of this volatile fatty acid will occur by *Syntrophobacter* if a methanogen such as *Methanospirillum* is present to consume molecular hydrogen according to the following reaction:



The methanogen has a high affinity for H<sub>2</sub>, and the partial pressure of H<sub>2</sub> is <10<sup>-3</sup> atm. Through the consumption of H<sub>2</sub>, the methanogens shift the thermodynamics of the reaction, and oxidation of propionic acid by *Syntrophobacter* is now favorable. Thus, there is a tight metabolic coupling involving *Syntrophobacter*–*Methanospirillum*, and this relationship has been called *interspecies hydrogen transfer*. Similarly, *Syntrophobacter* will oxidize propionic acid if other hydrogen-oxidizing bacteria such as sulfate reducers are present. In the rumen of cattle, *Clostridium cellobioparum* hydrolyzes cellulose to

low-molecular-weight polymers, which are fermented to acetic acid, lactic acid, CO<sub>2</sub>, and H<sub>2</sub>. However, this bacterium is inhibited by the accumulation of H<sub>2</sub> and is dependent on methanogenic bacteria to remove H<sub>2</sub>. The contribution of a second microorganism consuming end products that are inhibitory to the first bacterium is an example of synergism.

An interesting example of syntrophy exists when an anaerobic bacterium grows with an anaerobic archaea. In pure culture *Syntrophus aciditrophicus* can grow on energy from the fermentation of crotonic acid. Cultures of *Methanospirillum hungatei* grow with the production of methane using formic acid and molecular hydrogen. In coculture, these two microorganisms can grow on benzoic, butyric, hexanoic, and heptanoic acids, while neither of these organisms can grow on the organic acids when in a pure culture.

## 6.4 SYMBIOTIC ASSOCIATIONS

Over the years, the term *symbiosis* has been used to characterize various situations where different species are found living together. In the broadest definition, symbiosis has been used to describe biological interactions known as *mutualism*, *commensalism*, and *parasitism*. If the application is limited, symbiosis is used to describe the relationship where both organisms involved benefit, and in this case it could also be called *mutualism*. In this chapter, the discussion of symbiotic associations between microorganisms results in benefits to both partners. There is great diversity of symbiotic relationships with cyanobacteria, and this underscores the great capacity of these bacteria to adjust to changes in the biological environment (Adams 2000). This chapter discusses the relationships of cyanobacteria or algae with another single-cell partner. The resulting symbiosis between the photobiont and the host cell may produce a small cellular form or may result in macroscopic forms such as lichen and *Geosiphon*.

### 6.4.1 Diatoms

Diatoms are unicellular algae with cell walls of silica, and species of diatoms are found in freshwater or marine environments. Cyanobacteria are known to have either an intracellular or extracellular association with diatoms (see Table 6.4) and are referred to as *cyanobionts* (Janson 2002). The nitrogen-fixing activity of these cyanobionts is important for supplying ammonia to the diatom in environments where nitrogen limits growth. Some species of the cyanobacteria contain heterocysts, while coccoid cyanobacteria do not have heterocysts; however, both types of cyanobacteria are capable of nitrogen fixation. The major contribution of the diatom is the fixation of carbon dioxide, which provides the symbiont with sugars, although the cyanobiont also fixes carbon dioxide.

In cases where the cyanobionts are intracellular, two to five cyanobacterial cells occur in the cytoplasm of the host diatom cell, and symbiosis is maintained by vertical inheritance. The diatom–cyanobiont specificity is significant, and reinfection of diatom by intracellular cyanobacteria is rare. Some species of cyanobacteria may be epiphytic, or extracellular, and grow on the surface of diatoms. The epiphytic association may be less stable than the intracellular symbiosis and also may function to disperse cyanobacteria in new environments. One of the more complex associations is tripartite extracellular symbiosis, with the chain-forming diatom (*Leptocylindrus*), an epiphytic aplastic protist (*Solenicola*), and a cyanobacterium (*Synechococcus*) found embedded in the extracellular matrix surrounding the protist.

TABLE 6.4. Single-Cell Symbiotic Systems: Cyanobacteria Associated with Diatoms

Cyanobacteria	Diatom Species	Characteristics
Nonheterocyst containing <i>Epithemia turgida</i> or <i>Rhopalodia gibba</i> <i>Synechococcus</i> sp.	<i>Climacodium frauenfeldiorun</i>  <i>Leptocylindrus mediterraneus</i> with <i>Solenicola setigera</i> (protist)	Intracellular symbiont  Extracellular tri-partate
Heterocyst containing  <i>Richelia intracellularis</i>  <i>Calothrix rhizosolenia</i>	Tropical or subtropical marine diatoms  <i>Rhizosolenia</i> , <i>Hemiaulus</i> , or <i>Chaetoceros</i>  <i>Rhizosolenia</i> , <i>Hemiaulus</i> , or <i>Chaetoceros</i>	Intracellular symbiosis  Epiphytic association

### 6.4.2 Lichen

Lichen result from the intermicrobial symbiosis between fungi with septate hyphae and cyanobacteria. The mycobiant is generally an ascomycete; however, in tropical regions several examples with basidiomycete fungi are known. In most cases, the phycobiont is a single species forming a bipartite association, but in a few cases a tripartite association is formed where the phycobiant contains two photosynthetic organisms: a cyanobacterium plus a green alga. Lichens form a close symbiotic unit and are found in harsh ecosystems where neither the photobiont nor the fungus is able to grow independently. If conditions change to enhance growth of either microsymbiont, the partnership is lost. While there may be about 15,000 different fungal species with a green alga, there are about 1500 fungal species with heterocyst-containing cyanobacteria, the most common of which is *Nostoc*. Over 500 species of fungi form a tripartite association with a cyanobacterium plus a green alga. Because lichens represent a stable partnership, taxonomists classify lichen thallus using genus and species designations. Identification of partners in the symbiotic partnership has been difficult when using traditional physiological studies; however, the application of molecular biology techniques enables researchers to accurately determine the species through sequence analysis of 16S rDNA. Evaluation of the various strains of *Nostoc* by comparison of lichen for nucleotide sequence of the tRNA<sup>Leu</sup> (UAA) intron reveals considerable variability of the different isolates of cyanobacteria present in lichens.

Reproduction of the lichen is either sexual or asexual. Since most of the fungi are ascomycetes, ascospores are released into the environment and the lichen relationship is established when the algae encounters the mycelium of a suitable fungus. With asexual dispersal, a specialized unit known as the *soredia* is produced on the thallus of the lichen, and it consists of several algal cells along with the fungal hyphae. Air currents move the fungal–algal cells into a new environment where it will initiate growth.

Although fossil lichens are rare, cyanolichen have been located in “400-million-year old Rhynie chert.” Molecular analysis of DNA from lichen partners reveals considerable variation in lichen partners, suggesting that the symbiosis may have arisen at several different times. If there were, indeed, numerous points in evolution where symbiosis did occur, this would explain the great diversity of lichens as well as the distribution of lichens in open tundra, rainforests, and marine and desert environments. While this

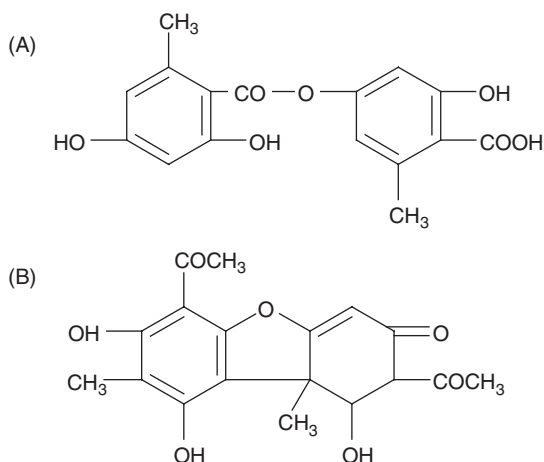


establishment of new lichen symbiosis may have been relatively infrequent, there probably were some instances where fungi lost their photosymbiont partners. Treeborne lichens are endosubstratic and grow mostly within the bark, but lichen that grow in cracks of rocks are endolithic.

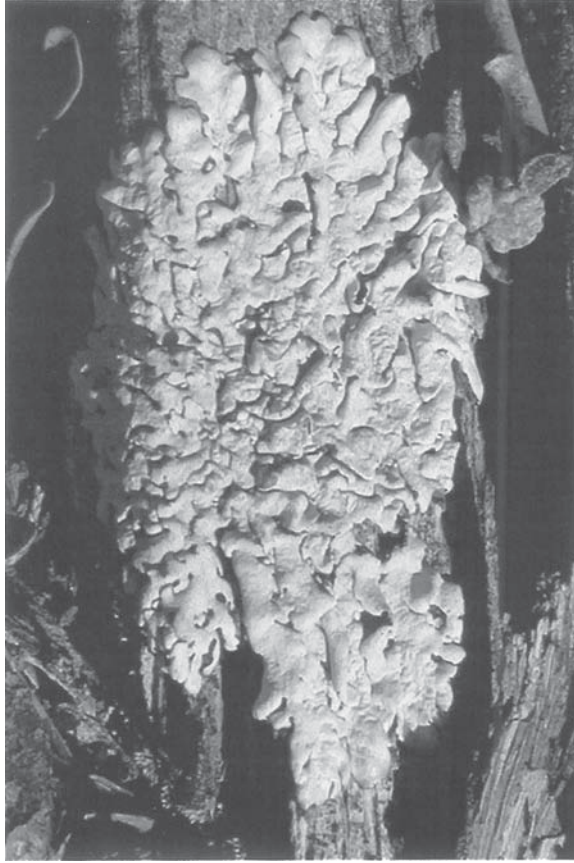
The lichen thallus consists primarily of fungi with the mycelium surrounding the cyanobacteria or algal cells and provide appropriate shade for the photosymbiont to avoid photoinhibition due to intense sunlight. Depending on the photobiont involved, different sugars are released into the mycobiont such as glucose, sorbitol, ribitol, or erythritol. Mannitol may accumulate in the mycobiont and may be one of several molecular types of compatible solutes that function in osmoregulation and retention of water. Phototoxicity in dried lichen is avoided because the photoreceptor system appears to be uncoupled from photosystem II. When water is added to dried thallus, respiration, solute transport, and photosynthesis starts to function within a few minutes. After a few hours of hydration, all of the activities of the activated thallus are restored.

Lichens may be black, green, or shades of yellow to brilliant red. Extracts of lichens have been used as dyes for clothing (e.g., Harris Tweed) and pH indicators (litmus). Reindeer moss is an example of lichen growing on the tundra, and while it is commonly used as food for caribou or reindeer, it can also be a high-carbohydrate food for humans, although it is not very tasty. Secondary metabolites produced by the fungi include various organic acids (see Figure 6.4) and other novel compounds important in mineralization of rock surfaces and protecting the lichen. Additionally, secondary products of cyanobacteria such as polybrominated compounds protect sponges from predatory fish.

According to general morphology, lichen thallus is designated as either foliose (Figure 6.5), crustose (Figure 6.6), or frutiose (Figure 6.7). Common to all is a cortex consisting of a compact layer of fungal cells and a central region called the *medullary layer* that consists of loosely woven hyphae. The photobiont layer lies between the cortex and the medullary layer or dispersed in the medulla. There is a difference in attachment of the thallus to the substratum. Crustose lichen is undifferentiated with a



**Figure 6.4.** Water-insoluble acids secreted from lichen thallus (although this not has been definitively demonstrated, many believe that the fungus symbiont synthesizes these organic acids): (A) lecanoric acid; (B) usnic acid [for more information, see Honda and Vilegas (1999)].



**Figure 6.5.** The foliose lichen grows flat on the substratum with leaf-like arrangements (photograph provided by Kenneth Ingham). See insert for color representation.

crust-like body that is attached to the substratum. In crustose, the thallus is attached to the substratum by rhizines that are fungal hyphae uniformly dispersed at the bottom of the thallus (see Figure 6.8). Foliose are highly lobed with flat leaf-like appearance. With foliose lichen, the thallus is attached to the substratum by hyphae bundled into units, and these units are found intermittently dispersed on the base of the thallus. Fruitiose lichen contains small branch-like features that are projected from a narrow base. The fruitiose lichen branches consist of interwoven hyphae, and these are attached to the substratum. In foliose and fruitiose lichens, haustoria do not penetrate the cell wall of the photobiont, but the thin fungal cell walls are tightly layered on the phototrophic cell. Approximately 20% of the photobiont cell is covered with the hyphae.

### 6.4.3 *Hatena*

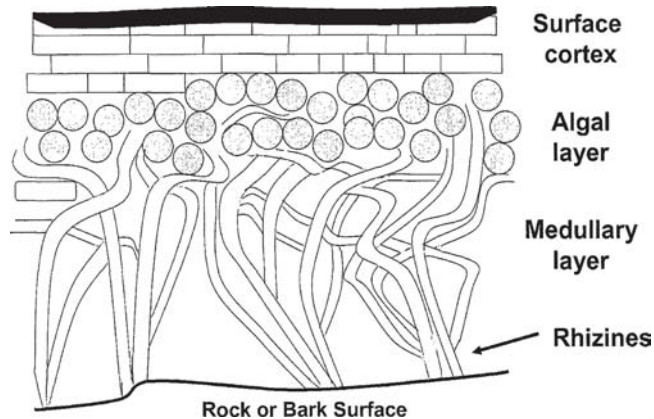
*Hatena* (Japanese; unusual) is a single-cell eukaryote found in the ocean that establishes an interesting association with a green alga cell (Okamoto and Inouye 2006). The host, *Hatena arenicola*, is motile by two flagella and is a heterotroph that feeds on algae



Figure 6.6. The crustose form of lichen grows flat on the substratum and has a crustaceous appearance; the type of crustose lichen that forms bright yellow colonies is *Xanthora aureola*, and the yellow color is attributed to parietin, a quinone. See insert for color representation.



Figure 6.7. The thallus of the fruticose lichen is generally upright and branched, or it may be pendulous (photograph provided by Diana Northup). See insert for color representation.



**Figure 6.8.** General structure of crustose lichen growing on a solid surface. The cyanobacterial cells are at the upper periphery of the lichen structure, and the fungus cells are dispersed throughout the lichen and secure the lichen onto the solid surface.

using a complex feeding tube. When the algal species ingested is *Nephroselmis*, the ingested algae becomes an endosymbiotic chloroplast that replaces the feeding apparatus. The endosymbiont functions like an eyespot and directs the host toward optimum light intensity. Without the endosymbiont, *Hatena arenicola* is unable to divide, but with the acquired endosymbiont, it is capable of cell multiplication. On the formation of two *Hatena* daughter cells from division, one cell retains the chloroplast and is green while the other is colorless, due to the loss of the chloroplast. Presumably, the protozoan without the endosymbiont develops a feeding system and ingests an appropriate strain of *Nephroselmis*. This lifecycle of *Hatena* is unusual because it alternates between being a heterotroph and an autotroph.

#### 6.4.4 Symbiosis between Bacteria and Protozoa

Some of the nonpigmented dinoflagellates have cyanobacteria located on the exterior of the host cell in chambers or pockets. These cyanobacteria can be readily characterized by their differences in thylakoid arrangement, carboxysomes, and cell form. It may be that the host moves the cyanobacteria into regions where oxygen levels are low and nitrogen fixation is favored. The dinoflagellate would benefit by receiving usable nitrogen from the cyanobacteria. In other examples, a cryptomonad, *Cyanophora paradoxa*, harbors a cyanobacteria-like cell as an intracellular symbiont (Hall and Claus 1963), and a ciliated protozoan, *Paramecium bursaria*, has a cytoplasm filled with *Chlorella*-like green alga.

In the ciliated protozoan, *Paramecium aurelia*, there are specific endosymbiotic organisms that resemble Gram-negative bacteria. Historically the granules inside the *P. aurelia* have been called *kappa factor*; however, it is now known that there may be several different prokaryotes serving as endosymbionts within their cell. The role of the kappa and related factors is to produce a toxin that kills paramecia that do not contain the endosymbiont. The bacteria are unable to divide unless they are inside protozoa that contain a specific *K* gene. It has been proposed that protozoa were the first hosts for pathogenic bacteria, and that it was within these eukaryotes that bacteria evolved some of their virulence factors responsible for pathogenicity.

## 6.5 FUNGUS–BACTERIUM SYMBIOSIS

Rice seedling blight is attributed to *Rhizopus microsporus*, which contains the bacterium *Burkholderia* as an endosymbiotic partner. This bacterium produces the rice-killing toxin called *rhizoxin*, and the presence of the bacterium is required for the fungus to produce spores. The fungal spores are infected with the bacterium, and this ensures that the fungal–bacterium association will be maintained.

## 6.6 PROKARYOTE–PROKARYOTE INTERACTIONS

### 6.6.1 Two-Member Mutualism

*Chlorochromatium aggregatum* was the designation initially given to an aggregate found in anaerobic waters. It is now known that two different bacteria are growing in a mutualistic symbiotic relationship: (1) a sulfate-reducing bacterium that converts sulfate to sulfide and (2) a green photosynthetic bacterium, *Chlorobium chlorochromatii*, using sulfide as an electron donor. It has been suggested that the photosynthetic bacterium may produce acetate, which is used for growth of the sulfate-reducing bacterium. It is unknown whether the sulfate-reducing bacterium is a specific species or if several different species can assume this role in symbiosis.

In 2002, Karl Stetter discovered an interesting symbiotic relationship between two hyperthermophilic organisms, both of which are members of the Archaea domain. *Nanoarchaeum equitans* is a tiny cell measuring 400 nm in diameter that grows only in coculture with the archeon *Ignicoccus* sp. Genetic analysis (Waters et al. 2003) explains the obligatory requirement of *N. equitans* for the larger *Ignicoccus*. With a genome of only 0.49 Mbp, *N. equitans* is missing genes for the synthesis of most nucleotides, lipids, cofactors, and amino acids. Apparently *N. equitans* obtains these essential components from *Ignicoccus*. See Section 2.6.1 for additional information about this microorganism.

### 6.6.2 Examples of Parasites and Predators

**Obligate Predators.** The first organism in the BALO group to be discovered was *Bdellovibrio* sp., and most of these are obligate periplasmic predators, although a few host-independent strains have been identified. Other BALO that grow in the periplasmic region of Gram-negative cells include *Peredibacter* and *Bacteriovorans*. Cells of *Bdellovibrio* have a single polar flagellum and are the fastest motile bacteria in that they move at 100 cell lengths per second. On striking of a Gram-negative bacterial cell, hydrolytic enzymes are released and along with the cell rotation the *Bdellovibrio* become located in the periplasm, where it loses its flagellum. Following the digestion of the cell wall, the host cell loses its rigid shape, and the resulting unit is called a *bdelloplast*. Enzymes from the *Bdellovibrio* are released into the cytoplasm of the host where degradation of proteins and nucleic acid polymers occurs. The *Bdellovibrio* cells divide by binary fission with the production of about four cells in 4 h and leave the dead prey. The *Bdellovibrio* cells acquire flagella and rapidly swim to encounter another prey. In laboratory studies, the two members involved are usually *Bdellovibrio* spp. and the bacterium



*Escherichia coli*. However, in natural environments many cells are not appropriate prey and are referred to as *decoys*. *Bacillus subtilis* is a Gram-positive bacterium and studies have involved using it as a decoy in the *Bdellovibrio*-*E. coli* interaction (Hobley et al. 2006). It appears that if decoy bacteria produce high quantities of hydrolytic enzymes, they may stimulate growth of *Bdellovibrio* because amino acids and sugars released from debris of dead cells are readily assimilated by the *Bdellovibrio*.

Two genera of BALO that attach onto the surface of appropriate cells are *Vampirococcus* and *Micavibrio*. *Vampirococcus* have a polar flagellum that promotes the collision with the purple sulfur phototrophic bacterium *Chromatium* spp. The predator cell uses pili to attach *Vampirococcus* to the surface of the prey, and while attached to the cell surface, the nutrients from the *Chromatium* cell are transported to the *Vampirococcus*. This action of one cell “sucking” nutrients out of another cell resembles the activity of a vampire and thus the name *Vampirococcus*. *Micavibrio aeruginosavorus* is a small rod-shaped bacterium that will prey on *Pseudomonas aeruginosa*, *Klebsiella pneumoniae*, and *Burkholderia cepacia* but not on other Gram-negative bacteria. Like *Vampirococcus*, *Micavibrio* grows only if attached to the surface of an appropriate bacterial cell.

There is one bacterial species that grows by cytoplasmic invasion of *Chromatium* sp. This organism is named *Daptobacter* because *dapto* in Greek means “devour or know.” *Daptobacter* enters the cytoplasm and while there obtains nutrients to support its growth. It may be assumed that additional species of bacteria will be invaded by bacteria similar to *Daptobacter*. This invasion of a bacterial cell and stabilization of the invader has led some to suggest this to be an important process needed for the formation of the first eukaryotic cell.

Considerable interest has been given to the obligate predators because epiphytic predatory bacteria with their limited prey selection would be useful for control of bacterial biofilms. This is based on the observations that *Micavibrio aeruginosavorus* needs only a few cells to initiate the predatory process, and the predatory has a narrow focus on prey with no harm to other microorganisms. Additionally, the predator is not harmed by toxins or antibacterial compounds released from other bacteria in the biofilm (Kadouri et al. 2007). Clearly this topic of predator bacteria in the environment will receive attention in the future.

**Facultative Predators.** Bacteria that can grow either with or without predation are known as *facultative predators*. With a few species of bacteria, there is a mass movement of cells across a moist surface, and unrelated individual dead or live cells may be overcome and digested. One group of bacteria that display this activity is the “fruiting body bacteria.” These bacteria are collectively called *myxobacteria* even though they are found in several genera, including *Stigmatella*, *Myxococcus*, and *Chondromyces*. (See Section 3.5 for additional information on fruiting body bacteria.) The myxobacteria are especially prominent in decomposition of plant material, and as part of their reproductive strategy will signal individual cells to aggregate by gliding motility (Kaplan 2003). The result is the formation of a multicellular structure that produces myxospores. Another bacterium that is a facultative predator is *Lysobacter*. This organism is similar to myxobacteria with the exception that it does not produce myxospores. The migrating bacteria are Gram-negative and secrete digestive enzymes that dissolve both Gram-positive and Gram-negative bacteria regardless of whether they are dead or alive. The migrating cluster of individual cells represents “wolfpacks” because this feeding unit can accomplish what an individual cell is unable to do. Facultative predators do not stalk their prey but rather it is an opportunistic event following a random encounter.

**Grazing and Predation by Protozoa.** Two major selective forces shape the behavior of bacteria and their adaptations to their environment: the need to find food and other nutrients, and the need to avoid being eaten by predators. Who eats bacteria and other microorganisms? Quite a number of microorganisms graze on bacteria, and one of the most important is protozoa. Depending on the habitat, protozoa may be equally responsible for demise of a bacterial population. Two other predators play more minor roles in bacterial predation: *Bdellovibrio*, a bacteria predator on bacteria, and *myxobacteria*, which hunt socially using digestive enzymes on prey. Bacteria use a variety of strategies to escape predators, in particular protozoa. One strategy is to optimize the use of size. Bacteria combine their small size with great mobility to escape death. Some bacteria, such as *Pseudomonas* spp., form large flocks, while others such as *Comamonas acidovorans* form large filamentous cells that are difficult for predators to consume. Masking by bacteria or the development of armor, such as the S layer on some bacteria such as *Synechococcus*, are two other antipredation strategies employed by bacteria. Other bacteria produce toxins in an altruistic act that provides food for their fellow bacteria in the form of protists' cytoplasm that is released following death of the protist.

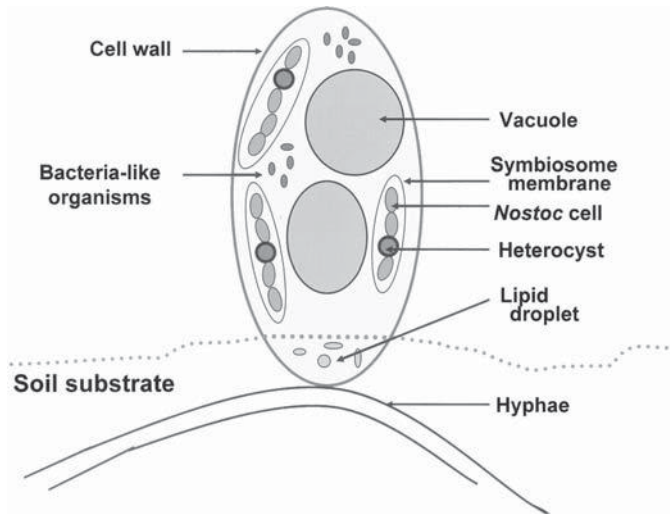
## 6.7 ESTABLISHING A SYMBIOSIS: THE NOSTOC–GEOSIPHON ASSOCIATION

*Geosiphon* is a cenocytic fungus that is found in moist soil and has numerous characteristics similar to those of endomycorrhizal fungi (Kluge et al. 2002). The cyanobacterium *Nostoc* is an endosymbiont associated with this fungus and is found in a pear-shaped bladder that is 1–2 mm long and 0.3 mm wide (see Figure 6.9). The bladder is found only above the soil and is highly sensitive to desiccation. Thus, the distribution of this *Nostoc*–*Geosiphon* association is relatively limited to moist environments. Establishment of this *Nostoc*–*Geosiphon* association is dependent on exposure to red and green light. In red light, *Nostoc* cells form a motile chain of cells, and this form persists for several days. When exposed to green light, the *Nostoc* cells become nonmotile and the cyanobacterium is taken up by the fungal cell. This relationship results from fungal lectins binding to mannose and other carbohydrates on the surface of the cyanobacterial cell. This is not an example of lichen because fungi in lichens have septate hypha and the lichen body is structurally distinct from that of either partner.

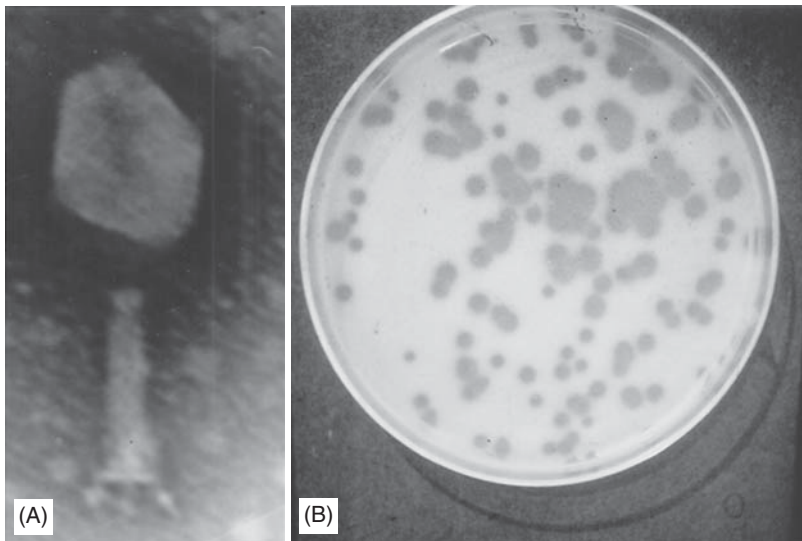
## 6.8 SEXUAL INTERACTIONS

Microorganisms of the same species may be stimulated through quorum sensing to display new phenotypes, appropriate for that specific environment. (See Sections 3.8.1 and Section 9.5 for additional discussions on quorum sensing.) Cell–cell interactions for the purpose of DNA transfer are highly detailed processes that are dependent on chemical recognition at the cell surface. While growth of prokaryotes is asexual, genetic material from related bacteria may be obtained by transduction or conjugation. In transduction, bacterial viruses kill donor cells (Figure 6.10) but in the process may transfer DNA to recipient cells. Since the initial discovery by Joshua Lederberg and Edward Tatum in 1946, bacterial conjugation has received considerable attention. As depicted in Figure 6.11, conjugation in *Escherichia coli* is initiated by the sex pilus of a male





**Figure 6.9.** Bladder-like structure found in the *Nostoc-Geosiphon* association. The bladder is found above the ground and in addition to *Nostoc*; it contains structures that are assumed to be bacteria. Nitrogen is fixed by the heterocyst in the *Nostoc* filaments.



**Figure 6.10.** Bacterial viruses: (A) electron micrograph of T4 bacteriophage active against *Escherichia coli*; (B) a plate showing *E. coli* infected by T4 and the clear zones result from the virus disrupting the bacterial cells. (Photographs provided by Larry Barton).

( $F^+$ ) cell binding to a female ( $F^-$ ) cell. Through a process of disassembling subunits of the pilus, the cells are pulled together. A single-strand copy of DNA is moved from the donor cell to the recipient cell by transporter systems specific for DNA. As the complementary strand of DNA is synthesized, the two cells separate and acquired DNA is expressed to benefit the recipient cell, and the donor cell retains information transferred.

In this process, genes may be transferred that reside on the bacterial chromosome or with a plasmid. As a result of conjugation, the recipient cell ( $F^-$ ) may acquire genes to convert it to a  $F^+$  cell. It is ecologically significant that through this process only a few  $F^+$  cells with a specific plasmid can efficiently transfer the plasmid to the  $F^-$  population. Additionally, bacterial conjugation without the requirement of a sex pilus is proposed for several species of Gram-positive bacteria. With *Enterococcus faecalis*, peptides released by the recipient cells appear to activate the transfer of DNA from donor cells.

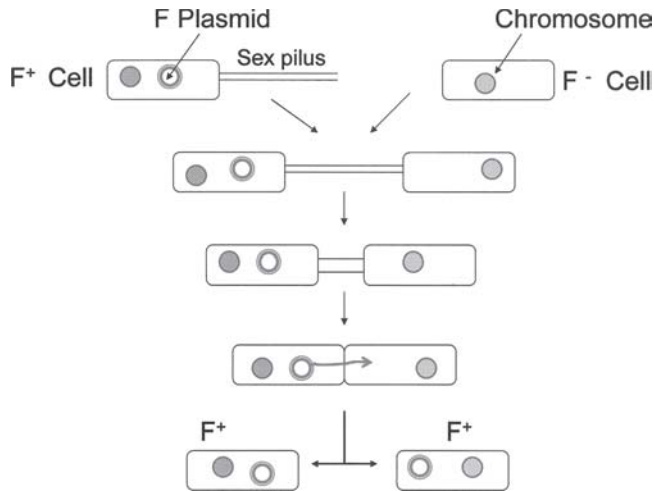
In eukaryotic microorganisms, each partner contributes a complete set of chromosomes in the sexual process. As reviewed by Sharma (2005), low-molecular-weight compounds are important pheromones for fungal mating (see Table 6.5). In *Mucor*, zygospore development results from hyphae of the plus (+) mating type produces prohormone (+), while hyphae of the minus (–) mating type produces prohormone (–) (see Figure 6.12). In lower fungi where sexual interaction results from male and female gametes, unique chemicals are produced by each differentiated cell. For example, the sex cells of *Achlya* (see Figure 6.13) and *Allomyces* produce chemicals that attract and stimulate the appropriate sex cells. These hormones or pheromones are especially important for enhancing fertilization for aquatic fungi that have motile sex cells. The resulting fertilized cell may be of ecological importance in producing additional progeny or maintenance of the species by formation of a resistive spore.

## 6.9 SUMMARY

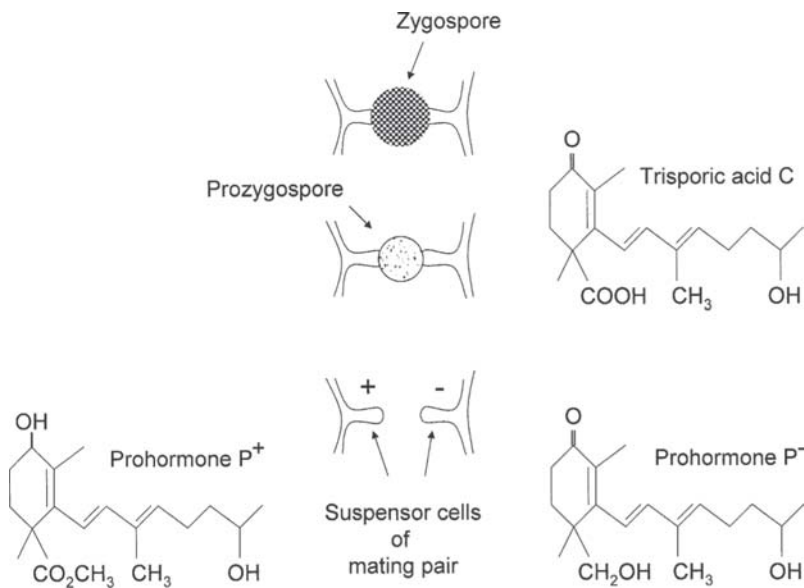
Microbial activities may assume several different activities and appear to be driven by the need for bacteria and other microorganisms to have a growth advantage in the immediate environment. In some instances the microorganism will partner with another and the result will be growth in a nutritionally limited environment or will result from some type of inhibitory action. Many of the interactions (symbiosis, predation, parasitism, etc.) are highly specific for microbial organisms, and organisms cannot survive outside this interaction. With some microbial interactions (e.g., competition, antagonism), there may be low levels of specificity but it is crucial because it limits or inhibits the establishment

TABLE 6.5. Examples of Pheromones Produced by Lower Fungi

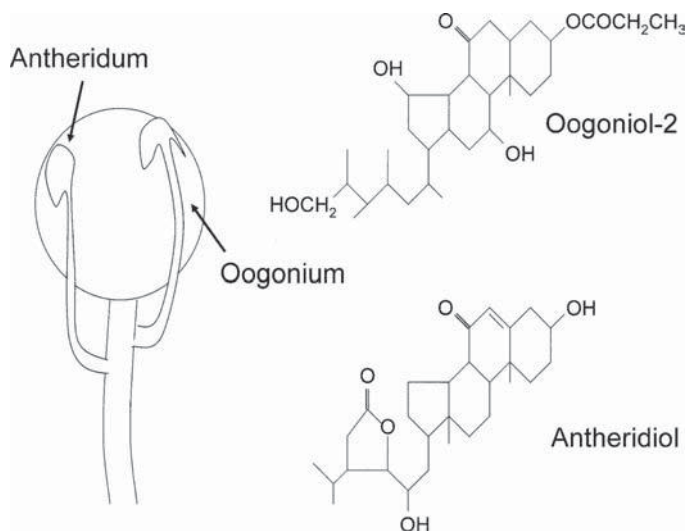
Hormone	Producer	Resulting Activity
Antheridiol	Female cells of <i>Achlya</i>	Stimulates male cells of <i>Achlya</i>
Oogoniol	Male cells of <i>Achlya</i>	Stimulates female cells of <i>Achlya</i>
Sirenin	Female gametes of <i>Allomyces</i>	Stimulates male gametes of <i>Allomyces</i>
Parisin	Male gametes of <i>Allomyces</i>	Stimulates female gametes of <i>Allomyces</i>
Trisporic acid	(+) and (–) cells of <i>Mucor</i>	Induces development of zygophores
$\alpha$ factor (peptide of 13 amino acids)	Secreted by haploid cells of <i>Saccharomyces cerevisiae</i>	Induces cell cycle arrest and expression of genes essential for mating



**Figure 6.11.** Model indicating conjugation by in *E. coli*, the Gram-negative bacterium. The  $F^+$  cell contains the F plasmid and has a sex pilus. The tip of the sex pilus specifically binds to the surface of the  $F^-$  cell, and the cells are pulled together as the length of the pilus is diminished. A single strand of DNA from the F plasmid is transferred into the recipient  $F^-$  cell, where the F plasmid is replicated and the recipient cell becomes  $F^+$ . Alternately, genes from the donor cell are transferred into the recipient, and following DNA processing, the recipient cell displays a new phenotype without becoming  $F^+$ .



**Figure 6.12.** Model indicating mating between partners of *Mucor* with the development of a zygospore. The (+) strain produces the prohormone  $P^+$ , which is converted to trisporic acid C to induce zygophore development. The (-) mating type produces the prohormone ( $-$ ), and this compound is also converted to trisporic acid C.



**Figure 6.13.** Model indicating chemicals produced by sex cells of *Achlya*. Antheridiol is produced by the female gametes and stimulates the antheridia of the male gametes. Oogoniol-2 is produced by the male gametes and stimulates the female gametes.

of dominance of a species in a given population of microorganisms. Low-molecular-weight compounds function as pheromones for mixing within a microbial species and provide specificity for mating activities. Thus, microbial activities resulting from cell–cell interactions should be considered as a response to chemical-coordinated activities and not as random interactions.

## 6.10 DELVING DEEPER: CRITICAL THINKING QUESTIONS

1. Describe and give an example of each of the following cell–cell interactions; (a) commensalisms; (b) syntrophy; (c) symbiosis; (d) competition; (e) neutralism; (f) parasitism; (g) predation; (h) antagonism.
2. Why do you think a large number of symbiotic cell–cell associations are involved cyanobacteria?
3. What is the basis for using lichen as indicators of sulfur dioxide and other toxic gases?
4. Describe the type of biological control attributed to either microbial production of antibiotics, the production of bacteriocins, or the production of extracellular enzymes. Why is it that viable bacteria can always be found in nature even though antibiotic or bacteriocin production occurs in that environment?
5. Identify and characterize each of the following: (a) BALO; (b) facultative predators; (c) host-dependent pathogens.
6. *Escherichia coli* grows extremely well in the intestine of humans and animals, but why is it that *E. coli* cannot persist in the soil?
7. Explain the following statement: A disease state occurs when cells in a symbiotic relationship become unbalanced.

8. To what extent would you expect cell–cell interactions to result from signal response activities? Defend your answer.

## BIBLIOGRAPHIC MATERIAL

### Further Reading

Jurkevitch E (2007), *Predatory Prokaryotes*, Microbiology Monographs, Vol. 4, New York: Springer.

### Cited References

- Adams DG (2000), Symbiotic interactions, in Whitton BA, Potts M, eds., *The Ecology of Cyanobacteria*, Dordrecht: Kluwer Academic Publishers, pp. 523–561.
- Brüssow H (2007), Bacteria between protists and phages: From antipredation strategies to the evolution of pathogenicity, *Molec. Microbiol.* **65**:583–589.
- Danovario R, Serresi M (2000), Viral density and virus-to-bacterium ratio in deep-sea sediments of the eastern Mediterranean, *Appl. Environ. Microbiol.* **66**:1859–1961.
- Darwin CR (1859), quoted in Bates M, Humphres PS, eds., *The Darwin Reader*, New York: Charles Scribner.
- Guerrero R, Pedros-Alio C, Esteve I, Mas J, Chase D, Margulis L (1986), Predatory prokaryotes: Predation and primary consumption evolved in bacteria, *Proc. Natl. Acad. Sci. (USA)* **83**:2138–2142.
- Hall WT, Claus G (1963), Ultrastructural studies on the blue-green algal symbiont in *Cyanophora paradoxa* Korschikoff, *J. Cell Biol.* **19**:551–563.
- Hobley L, King JR, Sockett RE (2006), *Bdellovibrio* predation in the presence of decoys: Three-way bacterial interactions revealed by mathematical and experimental analysis, *Appl. Environ. Microbiol.* **72**:6757–6765.
- Honda NK, Vilegas W (1999), The chemistry of lichens, *Química Nova* **22**:110–125.
- Janson S (2002), Cyanobacteria in symbiosis with diatoms, in Rai AN, Bergman B, Rasmussen U, eds., *Cyanobacteria in Symbiosis*, Dordrecht: Kluwer Academic Publishers, pp. 1–10.
- Kadouri D, Venzon NC, O’Toole GA (2007), Vulnerability of pathogenic biofilms to *Micavibrio aeruginosavorus*, *Appl. Environ. Microbiol.* **73**:605–614.
- Kaplan HB (2003), Multicellular development and gliding motility in *Myxococcus xanthus*, *Curr. Opin. Microbiol.* **6**:572–577.
- Kluge M, Mollenhauer D, Wolf E, Schuessler A (2002), The *Nostoc-Geosiphon* endosymbiosis, in Rai AN, Bergman B, Rasmussen U, eds., *Cyanobacteria in Symbiosis*, Dordrecht: Kluwer Academic Publishers, pp. 1–10.
- Okamoto N, Inouye I (2006), *Hatena arenicola* gen. sp. nov., a Katablepharid undergoing probable plastid acquisition, *Protist* **157**:401–419.
- Rai AN, Bergman B, Rasmussen U, eds. (2002), *Cyanobacteria in Symbiosis*, Dordrecht: Kluwer Academic Publishers.
- Sharma PD (2005), *Fungi and Allied Organisms*, Oxford, UK: Alpha Science International.
- Smith JMB, Marples MJ (1964), A natural reservoir of penicillin-resistant strains of *Staphylococcus aureus*, *Nature* **201**:151–156.
- Wallhäuser KH (1951), Die antibiotischen beziehungen einer natürlichen mikroflora, *Arch. Mikrobiol.* **16**:201–236.

Waters E et al. (2003), The genome of *Nanoarchaeum equitans*: Insight into early archeal evolution and derived parasitism, *Proc. Natl. Acad. Sci. (USA)* **100**:2984–12988.

Wommack KE, Colwell RR (2000), Virioplankton: Viruses in aquatic environments, *Microbiol. Molec. Biol. Rev.* **64**:69–114.

### Internet Sources

<http://nhc.asu.edu/lichens/>: *Arizona State University Lichen Herbarium*



# INTERACTIONS BETWEEN MICROORGANISMS AND PLANTS

## 7.1 CENTRAL THEMES

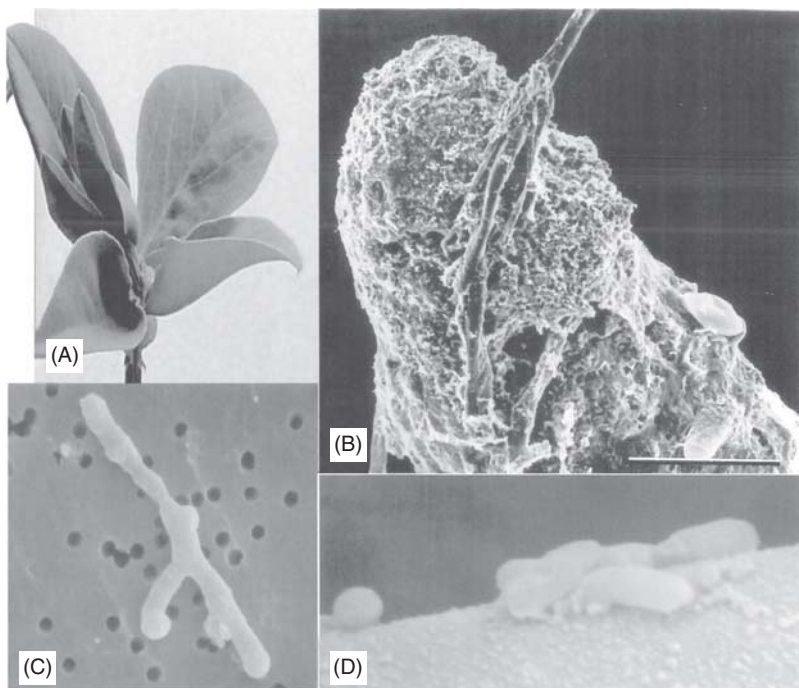
- Cyanobacteria have symbiotic relationships with several different cellular systems. This may be due in part to the fact that cyanobacteria provide carbon materials resulting from photosynthesis to the other partner.
- The rhizosphere is an environment where microbial activities contribute to plant growth. Bacteria and fungi grow on organic compounds released from the plant root and produce plant-line hormones.
- There are several types of mycorrhiza associations where fungi establish a persistent relationship with plant roots. In these relationships, fungi obtain minerals from the environment to support plant growth, and the plant root provides carbon compounds for the fungal cells to grow.
- Atmospheric nitrogen may be reduced to ammonia by cyanobacteria and other free-living prokaryotes. Nitrogen fixation is also observed, with rhizobia and frankia producing nodules on appropriate plant roots.
- A few species of bacteria and fungi are important plant pathogens infecting vascular tissues or decomposition of plant cell walls. Gall production on plants is attributed to infection by *Agrobacterium tumefaciens* that contains the Ti plasmid.

- Microorganisms can be used as biocontrol agents to control agricultural pests and pathogens. Soil fungi and bacteria contribute to the control of nematodes, insects, arthropods, and caterpillars.

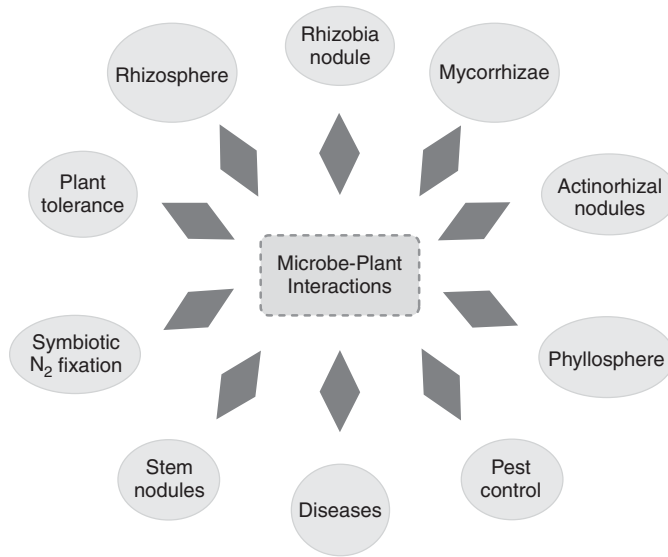
## 7.2 INTRODUCTION

Earth is richly populated with plants, and many different types of microorganisms grow in close association with them. While microbial activities detrimental to plant growth may be the most obvious, microorganisms are also beneficial to plants. As reflected in Figure 7.1, microorganisms may provide some nutritional benefit to a plant host, and this would result in increased plant growth. Over time different interactions between microorganisms (bacteria, fungi, or algae) and plants have been identified, and several of these activities are indicated in Figure 7.2. Perhaps one of the most obvious environments for microbe–plant interactions occurs in soil.

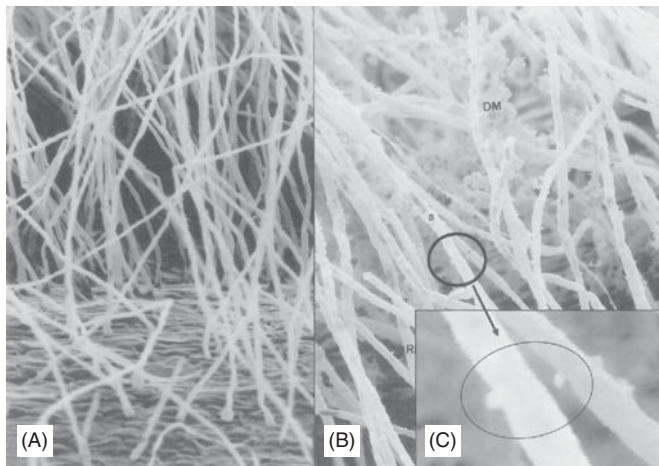
Plant roots have a lot of extensions from the central root (Figure 7.3), and bacteria may become localized on the root surface. In general, plants benefit from two types of microbe–plant associations: (1) highly specialized interaction, where there is considerable specificity found in mutualistic activities; and (2) commensalism resulting from nutrient secretion from plants when bacteria and fungi grow in close proximity to the roots but



**Figure 7.1.** Examples of microorganisms that interact with plants: (A) Broad bean (B) mycorrhizal fungus, *Glomus mossea*, extending from tip of grass root; (C) irregular shape of *Rhizobium meliloti* in root nodule of alfalfa [photos (A), (B), and (C) provided by Larry Barton]; (D) *Azospirillum brasilense* on plant root (photo provided by Janet Shagam).



**Figure 7.2.** Model indicating various plant–microbe interactions.



**Figure 7.3.** Root hairs on a corn (maize) seedling germinated in an environment without bacteria (magnification 4000×) (SEMs courtesy of Janet Shagam).

providing no apparent benefit to the plant. The two best characterized symbiotic systems are the fungus–root system and the bacterium–root nodule system. The beneficial aspects of plant–microbe symbiosis are well established in that the plants provide carbon material to support growth of the microbes and the bacteria or fungi promote plant growth by enhancing mineral uptake. With commensalism, the activity is less obvious than with symbiosis in that various chemicals are secreted from the leaves or roots of growing plants and these compounds stimulate the growth of bacteria. In rainforests and other moist environments, appreciable numbers of bacteria can be found growing on plant

surfaces, between plant cells, or only a small distance from plant leaves. In marine environments, the number of bacteria may reach a million/mL along the surface of red algal filaments. Because terrestrial plants do not synthesize vitamin B<sub>12</sub>, bacteria that have a requirement for this vitamin would not grow on chemicals released from plant cells. Plants limit microbial penetration by having a thick cell wall and other structural barriers that restrict infection. In addition, the defense system for plants includes the secretion of gums and chemicals to limit the invasion by bacteria and fungi. A disease results when the natural defense systems of the plant are ineffective.

### 7.3 SYMBIOTIC ASSOCIATIONS WITH CYANOBACTERIA

Cyanobacteria are broadly distributed in nature and form symbiotic relationships with many different organisms (Adams 2000; Rai et al. 2002). As seen from the listing of these symbiotic interactions in Table 7.1, cyanobacteria enhance their survival by establishing an association with a biological partner. The symbiotic activity of cyanobacteria with microorganisms is covered in Chapter 6 and with animals, in Chapter 8. Cyanobacteria are

TABLE 7.1. Examples of the Diversity of Cyanobacterial Symbiosis

Partner	Characteristic of Association	Genera of Principal Cyanobacteria
Ascidians	Sea squirts and tunicates	<i>Synechocystis</i> , <i>Prochloron</i>
<i>Azolla</i>	Aquatic fern	<i>Anabaena</i>
Cycads	An ancient group of seed plants with a specialized lateral root where cyanobacteria reside	<i>Anabaena</i> , <i>Calothrix</i> , <i>Nostoc</i>
Diatoms <sup>a</sup>	Single-cell, planktonic alga with silica cell walls	<i>Calothrix</i> , <i>Cyanothece</i> , <i>Epithemia</i>
Dinoflagellates <sup>a</sup>	Contain cyanobacteria in specialized structures or in the cytoplasm of dinoflagellates.	<i>Rhopalodia</i> , <i>Richelia</i> , <i>Synechococcus</i>
<i>Gunnera</i>	A tropical herbaceous angiosperm	<i>Nostoc</i>
Hornworts	Primitive plant	<i>Chlorogloeopsis</i> , <i>Nostoc</i>
Lichen <sup>a</sup>	Fungal and photobionts form a thallus	<i>Fischerella</i> , <i>Gloeocapsa</i> , <i>Gloeotheca</i> , <i>Hyella</i> , <i>Nostoc</i> , <i>Scytonema</i> , <i>Synechocystis</i>
Liverworts	Primitive seedless vascular plant with leaves arranged in two lateral rows	<i>Chlorogloeopsis</i> , <i>Nostoc</i>
Marine sponges	Multicellular primitive plant without organs; reproduces sexually or asexually	<i>Aphanocapsa</i> , <i>Oscillatoria</i> , <i>Phormidium</i> , <i>Synechocystis</i>
Mosses	Plant with multicellular rhizoids, have no flowers or seeds and leaves cover thin stems	<i>Anabaena</i> , <i>Oscillatoria</i> , <i>Phormidium</i>
<i>Geosiphon</i> <sup>a</sup>	A coenocytic soil fungus that has cyanobacteria in specialized cells	<i>Nostoc</i>

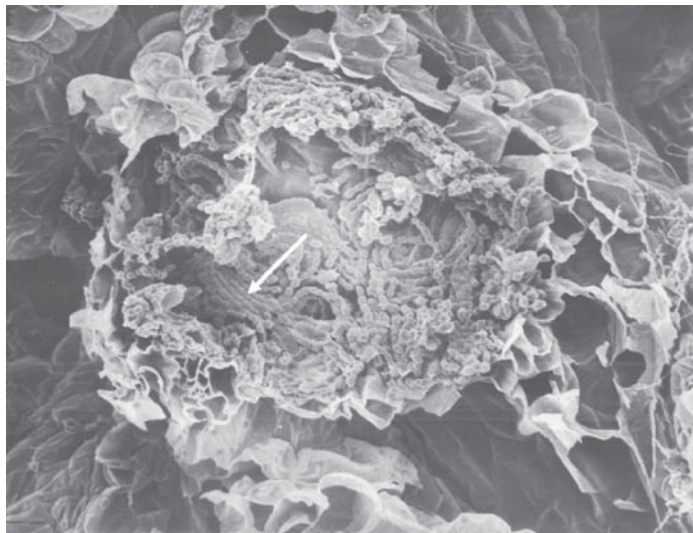
<sup>a</sup>Covered in Chapter 6.

found in a variety of environments, including those in symbiotic associations with plants. *Azolla* is an aquatic fern that contains bilobed leaves attached to a stem and is found floating in freshwater. This tiny plant has a symbiotic association with *Anabaena azollae*, where the cyanobacteria fixes atmospheric nitrogen and *Azolla* provides carbohydrates. The cyanobacteria are found in a cavity between the ventral and dorsal epidermal layers of the leaf. The cyanobacteria grow as a microcolony in the plant (see Figure 7.4).

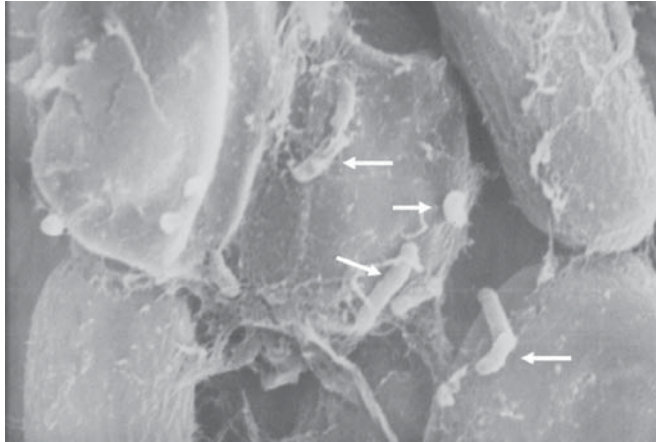
Nutrient exchanges appear to be by tiny fibers that extend from the plant into the cavity containing the clump of symbiont cells. As seen in Figure 7.5, bacteria-like organisms appear attached to *Anabaena* cells; however, little is known about these organisms. *Azolla* has long been used to enrich the nitrogen level of rice fields and is often used as a fertilizer known as “green manure.”

#### 7.4 INTERACTIONS IN THE RHIZOSPHERE

The soil layer that is within a few millimeters from the root system is the rhizosphere, which consists of soil and all the biological agents present in the soil. In practical terms, *rhizosphere* refers to the soil remaining on roots after a plant has been removed from the soil and gently shaken. This term was introduced by Lorenz Hiltner, a German botanist, in 1904, and this designation includes bacteria, fungi, algae, protozoans, and soil animals. Organisms of the rhizosphere are collectively referred to as *rhizospheric microflora* and grow in a complex community (Yanagita 1990). The microflora is characteristic for a specific cultivar, and greatest microflora activities are observed when plants are flowering. Soil bacteria that stain Gram-negative are more abundant than Gram-positive bacteria in the rhizosphere, and there are about 100–1000 times more bacteria in the rhizosphere than



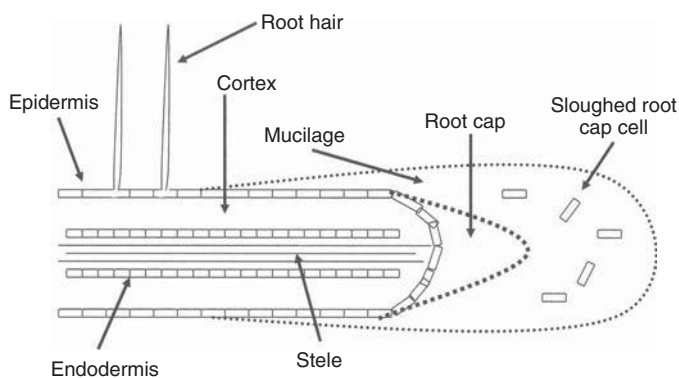
**Figure 7.4.** Scanning electron micrograph of interior of a frond of the aquatic fern *Azolla*; the cyanobacteria are present in trichomes that are not contained within a special vacuole or membrane (magnification is 8000 $\times$ ) (photograph provided by Gordon V. Johnson).



**Figure 7.5.** Bacteria-like organisms are indicated by arrows on the surface of the cyanobacterium *Anabaena*, which is associated with *Azolla* (magnification 8000 $\times$ ) (photograph provided by Gordon V. Johnson).

in the soil some distance from the root. With respect to actinomycetes, fungi, protozoans, and algae in the rhizosphere, the numbers are about the same as in surrounding soil.

Several different activities are found along the region of a growing plant root (see Figure 7.6). Elongation occurs at the root tip where mucilage is secreted and entraps materials released from the root. The dead root cells, mucilage, and organic acids secreted from the roots (e.g., citric acid and malic acid) are a source of carbon for rhizospheric bacteria and fungi. The release of organic acids and secretion of mucilage from plant roots is referred to as *rhizodeposition*. The amount of carbon loss from roots is often expressed as a percentage of net carbon fixed and can be considerable. For example, the carbon loss by tomato, pea, barley, and wheat has been estimated to be 35–40% of



**Figure 7.6.** Diagram of the apical region of a root. The apex of a root is the leading tip of the root, and behind the rootcap is the meristematic zone where rapid cell growth and differentiation occurs. Root hairs are found in the maturation zone, and the elongation zone lies between the meristematic and maturation regions. The stele contains both phloem and xylem. Rhizospheric microorganisms are abundant along this region of the plant root.



TABLE 7.2. Compounds Known to be Secreted from Plant Roots

Alcohols	Organic Acids	Small Organic Compounds	Large Organic Compounds
Ethanol	Isobutyric acid	Amino acids	Polysaccharides
Isobutanol	Malic acid	Nucleotides	Enzymes
Isoamyl alcohol	Citric acid	Sugars	
	Succinic acid	Vitamins	

total plant carbon. The compounds released from plant roots are listed in Table 7.2. The compounds secreted from the root are readily metabolized by soil microorganisms and enable microorganisms to have a high metabolic rate even though they are some distance from the root. For example, pseudomonads growing in the rhizosphere of *Pinus radiata* divide in 5 h but in the soil matrix some distance from the root the same bacteria requires 75 h for cell division. In addition to rhizodeposition, the death of surface root cells releases organic acids, proteins, nucleic acids, and complex carbohydrates for microbial growth.

In comparing the rhizosphere to nonrhizosphere environment, the pH of the rhizosphere generally is acidic as a result of proton secretion and can be as much as 2 pH units lower than in the soil. Under phosphorus or iron deficiency, plants secrete protons, citric acid, or caffeic acids to enhance solubilization of minerals. In addition to enhancing the cycling of C and N compounds, rhizospheric microorganisms consume O<sub>2</sub> and lower the redox potential of the rhizosphere. Important biochemical processes, such as nitrogen fixation, are enhanced under lower O<sub>2</sub> levels. Not all plant systems are identical because the gene content of a cultivar selects for specific bacteria and fungi in the rhizosphere.

The microorganisms on the root surface are present as microcolonies occupying a unique environment, and this environment is termed the *rhizoplane*. Rhizoplane microorganisms are present as microcolonies on the root covering only 10–30% of the root surface. This association of microorganisms is not uniformly distributed along the surface of the root, but microorganisms are found especially at the junction of the epidermal cell and at the base of root hairs. These areas represent regions where rhizodeposition is especially high. The microorganisms are not carried by extension of the plant root because fungi grow at a rate of 3 mm/day while the pine root, *Pinus radiata*, elongates 9 mm a day. For pea plants, the movement of *Pseudomonas fluorescens* is only 3 cm in 1 week, while the root elongates by 10–20 cm in a week. Additionally, the root extends through airspaces in the soil and bacteria moving through the soil are unable to keep up with the elongating root.

## 7.5 MYCORRHIZAE

Rhizospheric interactions of terrestrial fungi are influenced by the number of microorganisms, type of microorganisms, and specific plant root exudates. While many of these fungal interactions are highly transient, some fungi in the rhizoplane may establish a mutualistic relationship with the root. In 1885, this stable fungus–root relationship was first designated as mycorrhizae by Albert Bernard Frank, and over the years the description has been expanded to include both endomycorrhizae and ectotrophic mycorrhizae. Growth on the exterior of the root is characteristic of ectotrophic mycorrhizae, while growth inside the root is attributed to the endomycorrhizae or endotrophic mycorrhizae.



The mycorrhizal activities have been extensively reviewed by Davet (2004) and Adl (2003). Examples of root–fungus relationships are given in Table 7.3. Plants with mycorrhizae (either ecto- or endo-) are more capable of growing in low-nutrient soils, display greater growth rates and are more disease-resistant than are plants without the plant-associated fungi. When plants are introduced into low-nutrient soil, there is an obvious benefit to plants inoculated with mycorrhizal fungi, as can be observed from growth (see Figure 7.7). A significant benefit to the plant with either endomycorrhizae or ectomycorrhizae fungi is the enhanced uptake of nutrients from the soil. The zone of nutrient absorption by root hairs is only a few millimeters, while the ectomycorrhizae may extend 20 cm or more from the root while the endomycorrhizae may scavenge for nutrients for about 8 cm from the root. How the root–fungus symbiosis is initiated is not understood, but it is believed to involve chemical signaling to promote the growth of fungal cells on the surface of the roots. The terms *mycorrhizae* and *mycorrhizas* are plural expressions, while *mycorrhiza* is singular and refers to a specific root–fungus association.

### 7.5.1 Ectomycorrhizae

Ectomycorrhizae are commonly found on tree roots of gymnosperms or woody angiosperms, and fungal partners include members of the nonseptate fungi. Approximately 6000 fungal species form ectomycorrhizae, and ~75% of these will produce aboveground reproductive structures commonly called “mushrooms.” Most ectomycorrhizae fungi are basidiomycetes; however, a few are ascomycetes, and these form subterranean reproductive structures known as “truffles.” In some cases the symbiosis may be highly specific in that only a few fungi may associate with the roots, while in other cases a considerable lack of preference by roots for fungi is displayed. For example, over 2000 different fungal species can establish ectomycorrhizal association with Douglass fir. Examples of this mutualistic partnership are given in Table 7.3.

Conifers and deciduous broadleaf trees (especially oak, beech, eucalyptus, and hickory) are hosts for the mycorrhizal fungi, and plants placed in nutrient-deficient soils will not grow unless appropriate mycorrhizal fungi are added. Certainly, woodland soils would be considered nutrient-deficient as compared to fertile agricultural soils, and this nutrient limitation in soil accounts for the broad association of ectomycorrhizae with trees. The fungal hyphae develop around the roots of tree seedlings with fungal invasion into the

TABLE 7.3. Examples of Mycorrhizal Fungi Associated with Plants

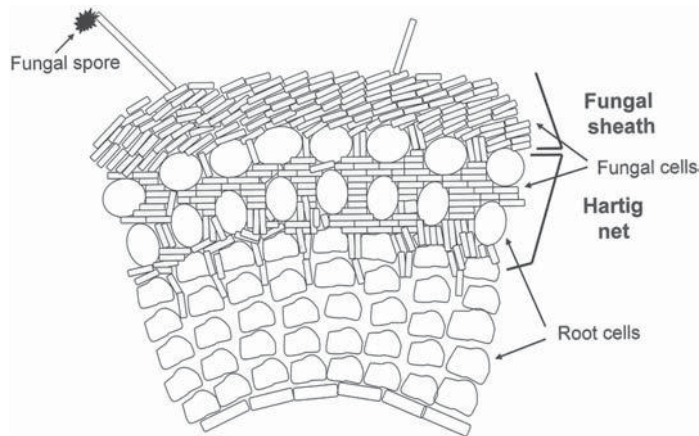
Mutualistic State	Fungal Species	Plants
Ectomycorrhizae	<i>Boletus elegans</i>	<i>Larix</i> sp.
	<i>Boletus scaber</i>	Birches
	<i>Lactarius deliciosus</i>	<i>Pinus pinea</i>
	<i>Pisolithus tinctorius</i>	<i>Pinus taeda</i>
	<i>Russula emetica</i>	<i>Pinus pinaster</i>
Endomycorrhizae	<i>Gigaspora margarita</i>	Cotton
Ericoid mycorrhizae	<i>Pezizella ericae</i>	Heather
Orchid mycorrhizae	<i>Armillaria mellea</i>	Orchid
	<i>Rhizoctonia solani</i>	



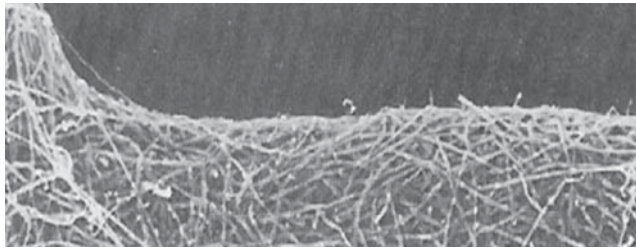
**Figure 7.7.** Growth of a plant species native to the southwestern United States in mine spoils; plants were inoculated with (A) *Gigaspora rosea*, (B) *Gigaspora mosseae*, and (C) *Acaulospora spinosa*; plant (D) was not inoculated with endomycorrhizal fungi (photograph courtesy of Gordon Johnson).

roots restricted to the penetration between the epidermal cells forming an intercellular association with the root cortex and rarely into the root cells (see Figure 7.8). Infection by fungi into the surface layers of the root produces a compact mass that is referred to as the *Hartig net*. Fungal hyphae grow extensively on the young root surface, producing a web-like mantle or sheath that may be 40  $\mu\text{m}$  thick and account for 40% of the dry mass of the root. The surface of a plant root covered with ectomycorrhizae is shown in Figure 7.9. As the fungi grow, the development of root hairs is suppressed and fungal mass assumes the role of root hairs in uptake of minerals and water. Also characteristic of the ectomycorrhizal association is the dichotomous branching and widening of the rootlets, and this is attributed to gibberellins and cytokinin phytohormones secreted by the fungus. In terms of root morphology, the root with associated fungus is thicker, shorter, and more branched than the fungus-free root. The impact of the fungi on root morphology is to decrease root cell elongation in the meristematic region.

The fungal hyphae extend into the soil, where they sequester phosphorus, nitrogen, sulfur, calcium, zinc, iron, and numerous minerals for fungal growth. When the plant becomes mineral-deficient or when the fungal cells die, the appropriate ion will be passed on to the roots. The plant provides sugars for the growth of the mycorrhizal fungus, and this level is significant in that it represents 5–20% of carbon fixed through photosynthesis. An additional benefit of a plant having mycorrhizal fungus is the trapping of nutrients. This is observed during periods of rain when nutrients are washed from the leaf litter into the soil but are immobilized in the mycorrhizal mantle before they can be carried out of the root zone. In an interesting observation by Simard et al. (1997), ectomycorrhizae were found connecting two separate plants about 0.5 m apart and the fungal mycelium provided



**Figure 7.8.** Diagram depicting the ectotrophic mycorrhizae in the cross section of a root. A few fungal hyphae extend into the rhizosphere from the fungal sheath or mantle. The Hartig net is formed by the network of intercellular hyphae. The fungal hyphae expand the surface area of the plant root, and fungal spores are produced on the hyphae extending into the soil.



**Figure 7.9.** Ectomycorrhizal fungi growing on the surface of pine tree root (photograph provided by Larry Barton).

a bidirectional flow of ions between seedlings. Additionally, when one of the plants was in the shade, translocation of nutrients was from the sun-exposed plant with high levels of photosynthesis to the shaded plant where the quantity of fixed  $\text{CO}_2$  was lower.

The ectomycorrhizal association is established at the early stages of seed germination as the first roots are produced. Spores of the ectomycorrhizal fungi are formed on the hyphae that extend from the root surface into the surrounding soil, and germination of these spores may be dependent on secretions from the plant roots. B-type vitamins, terpenoids, sterols, and flavonoids from plants and root secretions are considered important for regulating spore germination and early fungal cell proliferation. It appears that a limitation of nitrogen, phosphorus, potassium, and calcium in the soil coupled with adequate light intensity for photosynthesis accounts for an increase of sugars in the plant and the level of compounds secreted from the roots. In fertile soils, tree seedlings would not be nutrient-deficient but have a high retention of fixed  $\text{CO}_2$  in the plant with minimal to no requirement for mycorrhizal fungi. Generally, ectomycorrhizal fungi are incapable of digesting complex carbohydrates such as lignin or cellulose and require sugars, organic acids, amino acids, and vitamins (especially thiamine) for growth. These

requirements for growth limit the ability of the ectomycorrhizal fungi to successfully competing with saprophytic microorganisms in the soil. When provided with appropriate nutrients, many of the ectomycorrhizal fungi can be cultivated in the laboratory; however, some fungal species appear to have an obligate requirement for secretions from plant roots. Monocotyledons are not known to establish ectomycorrhizae.

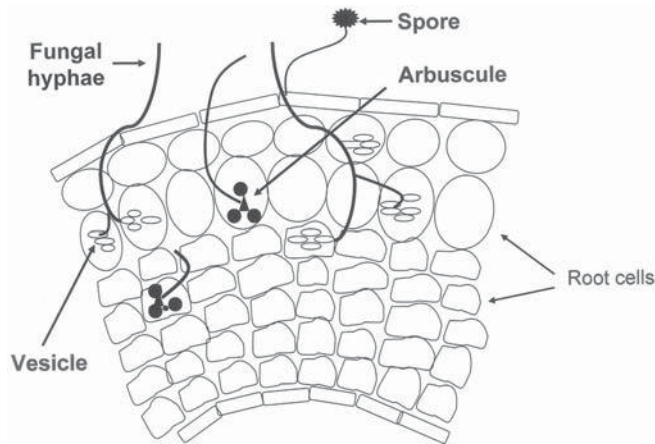
### 7.5.2 Endomycorrhizae

Endomycorrhizae are found on most herbaceous plants, including lower vascular plants such as ferns and bryophytes. As in the case with ectomycorrhizae, endomycorrhizal fungi benefit by obtaining organic acids, carbohydrates, and other carbon compounds from roots, while plants benefit from enhanced root uptake of mineral ions from the fungal cells. Endomycorrhizae are the most common type of mycorrhizae because they have been demonstrated in almost every plant family. Most forest trees contain both endomycorrhizae and ectomycorrhizae; however, only endomycorrhizae are found with juniper, ash, or maple. There are about 120 fungal species accounting for endomycorrhizal associations, and a lack of specificity is observed in that a fungal species may establish a mycorrhizal association with several different plant hosts. The nutritional complexities of these endomycorrhizal fungi have not been well established, and as a result few of these fungi have been cultivated in the laboratory. This development of endomycorrhizae is not recent, but there is fossil evidence that this mutualistic relationship evolved about 400 million years ago at the time when land plants were becoming established. Some believe that endomycorrhizae enabled plants to become established on land.

The spores of endomycorrhizal fungi have a thick wall, and under appropriate conditions germination will produce a germ tube with an emerging fungal cell. The germ tube must associate with a root because endomycorrhizal fungi have limited saprophytic metabolism. The fungi penetrate the root with growth between epidermal cells or through root hairs and invade cortex cells (see Figure 7.10). Unlike ectomycorrhizae, there is no Hartig net; nor is there a dense fungal sheath on the root. As the fungal haustoria penetrates the cortex cells, it does not damage the plasma membrane or the tonoplast as it produces a series of oval coils. This fungal vesicle contains lipids, glycogen, proteins, and other storage compounds. Another intracellular structure is an arbuscule, which is readily identified morphologically because it has a highly branched tree-like configuration. Thus, an alternate name given to endomycorrhizae is *vesicular–arbuscular mycorrhizae*. The mass of the fungi in this root symbiosis is about 10% of the root weight. Fungal hyphae may extend several centimeters from the root, and chlamydo spores may be produced in the soil matrix at the end of this filament (see Figure 7.11).

### 7.5.3 Other Mycorrhizal Associations

While the ectomycorrhizal and endomycorrhizal associations are the best known of the mycorrhizal associations, there are several other morphological types of mycorrhizae. Ectendomycorrhizae are characterized as having a relatively small fungal sheath, an extensive Hartig net, and fungal penetration into root cells. This intracellular activity is especially obvious in older roots. There are no specific trees or fungi attributed to this symbiotic state, but it appears to be a physiological response. In one environment ectomycorrhizae may be produced, but in another environment the same two partners



**Figure 7.10.** Diagrammatic representation of endomycorrhizae of the vesicular–arbuscular type. Fungal hyphae invade into the root cells where nutrients acquired by the mycelium in the rhizosphere are released into the root cells. Fungal spores are produced on hyphae extending from the plant root.



**Figure 7.11.** Growth of *Glomus albidus*, an endomycorrhizal fungus, on roots of *Hilaria* sp., a semiarid warm-season grass (SEM provided by Larry Barton).

may produce ectendomycorrhizae. In the plants of the Ericales, the symbiotic fungal association is called *ericoid mycorrhizae*. The mycorrhizal fungus is found in the root hairs that consist of only a few layers of cells. The fungus penetrates an epidermal cell, forming coils of hyphae inside the host cell. The ericoid mycorrhizae are commonly ascomycetes or basidiomycetes, and their presence stimulates plant growth and promotes fruiting by the plant.

The orchid mycorrhizae association is a variation of endomycorrhizae. It is a complex symbiosis involving fungal association with developing roots of an orchid and is especially important in growth of the germinating orchid. Unlike other mycorrhizal fungus–plant associations where the plant provides sugars for the fungus, the orchidaceous mycorrhizal fungus provides carbohydrates to the plant host. The fungus obtains nutrients from the surrounding environment by either saprophytic or parasitic activity and transfers the sugars to the orchid by endomycorrhizal association. Thus, there may be a tripartite relationship involving the orchid, the fungus, and the host plant providing the carbon nutrients. The fungi involved in the orchid mycorrhizae are widely distributed in nature. Typically, the fungi are saprophytic basidiomycetes, and unlike the ectomycorrhizae, these fungi have enzymes for the digestion of lignin, cellulose, or other complex carbohydrates. Digestion of the orchid cells by fungi in establishment of the intracellular fungi is carefully controlled to prevent fungal digestion of the orchid. If the fungus is too aggressive, the orchid dies, and if the orchid is too defensive, the fungus does not grow.

## 7.6 NITROGEN-FIXING BACTERIA AND HIGHER PLANTS

Examples of nitrogen-fixing bacteria that grow symbiotically with plants are given in Table 7.4. The enzyme system for nitrogen fixation is found only in the prokaryotes, and in the case of symbiotic nitrogen fixation in plants, there is considerable specificity between the legume symbiont and bacteria for the stable association. Specific bacteria infect either root hairs or stems of plants, and the most common association is the bacteria–root association. This association is highly beneficial for both the bacteria and the plant. The plant provides the carbon and energy source for the bacteria to grow, while the bacteria fix nitrogen with the production of amino acids for plant growth.

### 7.6.1 Root Associations

**Legume Nodules.** The association of nodules with roots of leguminous plants is one of the oldest reports in microbial ecology. In the late 1600s, Marcelo Malpighi made extensive drawings of legumes showing roots with well-developed nodules. In 1888, Martinus

TABLE 7.4. Examples of Symbiotic Associations between Nitrogen-Fixing Bacteria and Plants

Bacterial Symbiont	Plant Host
Nodule formation on roots of legumes	
<i>Bradyrhizobium japonicum</i>	Soybean
<i>Mesorhizobium ciceri</i>	Chickpea
<i>Rhizobium leguminosarum</i> bv. <i>phaseoli</i>	Bean
<i>Rhizobium leguminosarum</i> bv. <i>trifoli</i>	Clover
<i>Rhizobium leguminosarum</i> bv. <i>viciae</i>	Pea
<i>Sinorhizobium meliloti</i>	Alfalfa
Nodules produced on plant stems	
<i>Azorhizobium caulinodan</i>	Aquatic tropical legume
<i>Methylobacterium nodulans</i>	Clover
Nodules on roots of woody plants	
<i>Frankia</i> spp.	25 genera of dicotyledonous plants



Beijerinck isolated bacteria from the root nodules of legume plants and established the nitrogen-fixing capability of these bacteria when associated with plants. The bacteria that grow symbiotically with roots of legumes are frequently referred to as *rhizobia*, and currently these bacteria are assigned to four designated genera (see Table 7.4). The establishment of root nodules requires bacteria that can compete in the rhizosphere as well as establish a symbiotic relationship with roots. An important aspect for rhizospheric and symbiotic bacteria is iron nutrition, and Michael O'Connell is one of the leading experts addressing siderophore production by rhizobia (Lynch et al. 2001). The contribution of Michael O'Connell is discussed in the following microbial "spotlight."

### ***Microbial Spotlight***

#### **MICHAEL O'CONNELL**



Michael O'Connell surrounded by lush vegetation in Ireland.—(Photograph courtesy of Michael O'Connell).



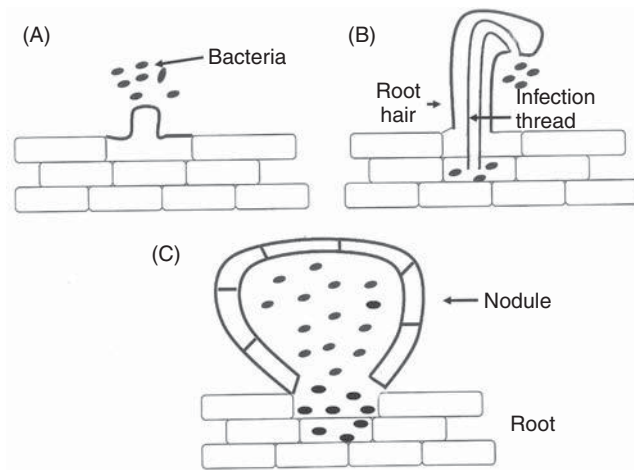
Michael O'Connell is Senior Lecturer in Biotechnology at Dublin City University, Ireland. When asked how he started his research in rhizobia–plant symbiosis, he replies:

I was keen on microbiology from the first year of my undergraduate studies and developed a particular interest in bacterial genetics. I was impressed by the speed with which complex genetic experiments could be accomplished using bacteria and phage. At that time recombinant DNA technology was emerging and my decision to undertake a Ph.D. in molecular microbiology was an easy one. My microbiology courses at undergraduate level had been primarily concerned with medical aspects. So when I was given the opportunity to do a project on *Rhizobium* and its symbiosis with legumes I was excited by the prospect of working with an interaction that involved an infection process but one that conferred benefits ecologically. Methods to investigate the genetics of rhizobia were just being developed. It was discovered that many *Rhizobium* species have a genome composed of megaplasmids, in addition to the chromosome. The contrast in genome organisation with the enteric bacteria was fascinating. Equally fascinating was the discovery of the process of signal exchange between the bacteria and the host plant during the development of the interaction. More recently the application of genomics and transcriptomics has completely transformed the way in which we study the symbiosis.

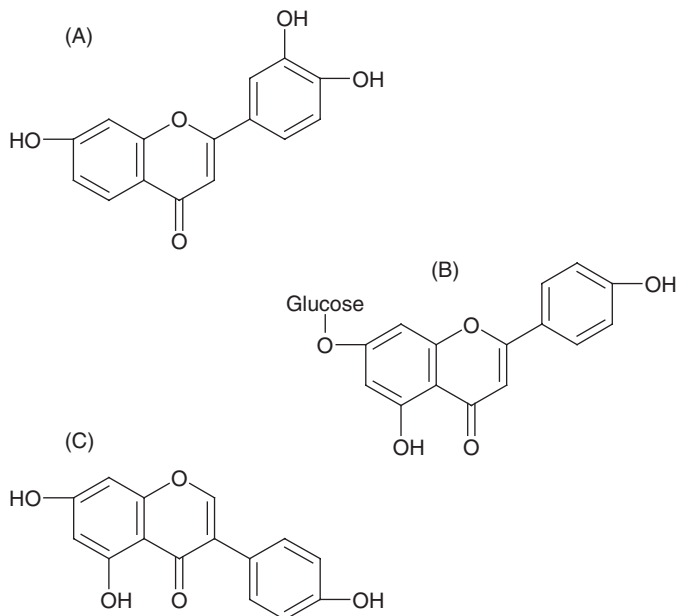
Michael has had considerable success in his publications (Viguiet et al. 2005), and when asked what propels his continued research, he is quick to answer: "This symbiosis makes a major contribution to the critical process of global nitrogen fixation and its study provides a real sense of purpose for those who investigate it."

Bacteria are specific for a legume species, and formation of the root nodule is the result of a unique differentiation process. A model representing some of the steps involved in the formation of a nitrogen-fixing nodule are presented in Figure 7.12, and the individual steps are summarized as follows:

1. The legume root secretes specific chemicals known as *flavonoids* (Figure 7.13), and these signaling molecules attract rhizobia growing in the rhizosphere.
2. The flavonoids also induce transcription of *nod* genes (Figure 7.14) in the rhizobial genome to produce lipochitin oligosaccharides, called *Nod factors*.
3. The plant root recognizes the chemical structure of the Nod factors, and these lipochitin oligosaccharide molecules are taken up by legume receptor kinases. The Nod factors activate the plant hair roots, and this recognition is responsible in part for the specificity between the host and legumes.
4. The symbiotic bacteria attach onto the root hairs and enter into the root by a process known as *root infection*.
5. The bacteria produce a lipopolysaccharide capsule that enables the rhizobia to evade plant defense systems and enter the root by a structure designated as the *infection thread*.



**Figure 7.12.** Development of root nodule in legume: (A) the sequence of events initiated by root hairs secreting a chemical to attract bacteria; (B) an infection thread is established to carry bacteria into the root cortex; and (C) nodule formation occurs. Additional information is provided in the text.

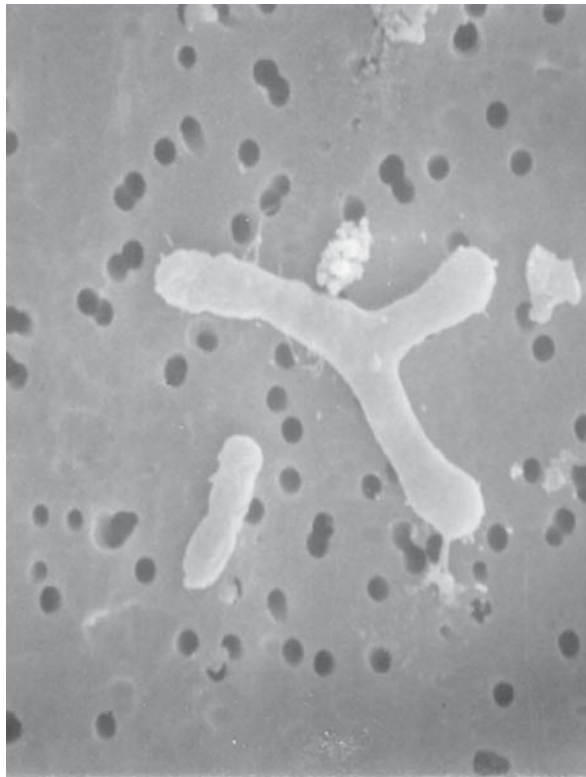


**Figure 7.13.** Flavonoid compounds produced by legume roots; these flavonoids interact with the *nod* genes of rhizobia. (A) flavone or luteolin secreted by alfalfa roots; (B) flavone glucoside or apigenin released from clover roots; (C) isoflavone or daidzein secreted from roots of soybean plants.



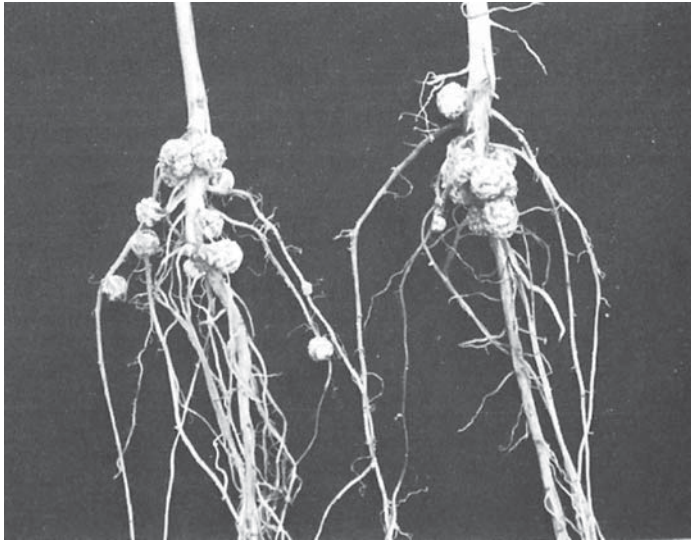
**Figure 7.14.** Gene cluster of the plasmid of *Rhizobium leguminosarium* var. *viciae*. Locations of the *nod* genes are indicated, and this plasmid contains two *nif* (nitrogen fixation) genes. The arrows indicate direction of transcription. The *nodD* gene is the regulator gene that controls transcription of other *nod* genes; *nodABC* genes encode for nod factor synthesis, *nodE* and *nodL* are responsible for host range, *nodM* encodes for glucosamine synthesis for nod factor synthesis, *nodF* produces a carrier protein required for the Nod A protein to act, and *nodI* and *nodJ* are required for export of nod factors from bacteria.

6. Phytohormones are produced by bacteria to stimulate root cell division, and the plant root expands quickly to produce a nodule.
7. Bacteria in the root nodule adjust to the low-nitrogen environment and the reduced oxygen level in the nodule. In some cases the bacteria differentiate to produce rounded cells or cells with a “Y” shape (Figure 7.15). These differentiated bacteria are bacteroids, and these cellular units are important in fixing nitrogen.

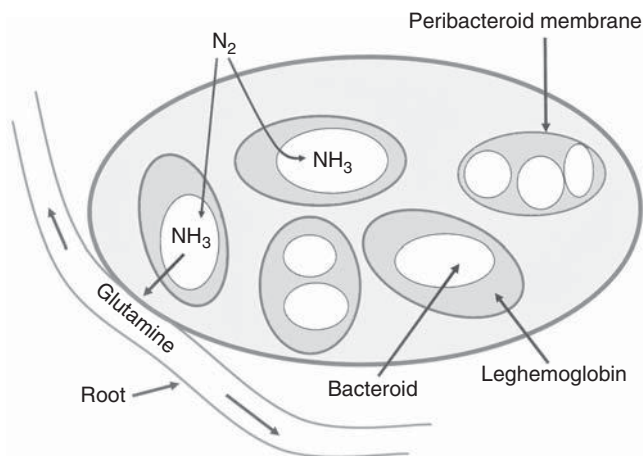


**Figure 7.15.** Unusual morphology of *Rhizobium meliloti* isolated from root nodules of alfalfa plants. Cells are seen by scanning electron microscopy with magnification of 8000 $\times$  (images provided by Larry Barton).

A photograph of soybean roots with nodules present on the root hairs is shown in Figure 7.16. Nitrogen fixation in the soybean nodule is attributed to the bacteroids, differentiated rhizobial cells, present in the symbiosomes (Figure 7.17). Because the nitrogenase enzyme is oxygen-sensitive, leghemoglobin in the nodule reduces the level of free  $O_2$  to enable nitrogen fixation. The product of nitrogen fixation is the production of glutamine, and this amino acid is transported by way of the root hairs to regions of protein synthesis. Most commonly there is a high level of specificity between bacteria



**Figure 7.16.** Soybean plants with root nodules attributed to symbiotic nitrogen-fixing rhizobia. The rough, round structures on the legume roots are the nodules, and each plant may have several nodules.



**Figure 7.17.** Model of legume root nodule. Symbiosomes in the nodule contain one or more bacteroids that fix nitrogen. See insert for color representation.

and the legume (Table 7.4) to establish a symbiotic state. However, some soil rhizobia may nodulate several legume species, and this may be attributed to lateral gene transfer of Nod factors between different rhizobia.

**Actinorhizal Nodules.** Another plant-root symbiosis associated with nitrogen fixation is the actinorhizal symbiosis (Vessey et al. 2005; Schwintzer and Tjepkema 1990). At least 25 genera of plants from eight plant families will interact with bacteria known as *Frankia* to produce a fibrous root nodule. *Frankia* are widely distributed in soils and grow in multicellular arrangements typical of actinomycetes. The *Frankia*–root interaction results in an actinorhizal nodule by a highly ordered process similar to legume nodule development. The plants involved are woody shrubs or small trees that are found worldwide, and Russian olive is one of the more common trees found in the United States. Nodule formation on the roots of a Russian olive tree is provided in Figure 7.18. Plant growth attributed to nitrogen fixation by actinorhizal plants was first observed by Woronin in 1866. The taxonomy of *Frankia* strains is not well established because the bacteria had been difficult to grow in the laboratory. However, DNA hybridization studies reveal that bacteria of several species exist among *Frankia* species. Many consider that the wide diversity of plants and microorganisms in actinorhizal symbiosis indicates that it is a much older process than the rhizobia–legume system.



**Figure 7.18.** Roots of Russian olive tree with nodule attributed to *Frankia*; nodules are indicated by the arrows (photograph provided by Gordon Johnson).

## 7.6.2 Stem Associations

In tropical and subtropical regions, aquatic legume species have nitrogen-fixing nodules on their stems. Generally nodules are produced on the submerged stems or on stems at the air–water interface. The systems best studied involve the legume *Sesbania rostrata* with nodules produced by *Azorhizobium caulinodan* and the legume *Aeschynomene indica* with *Bradyrhizobium* strain BTAi1. These bacteria are interesting because they also contain bacteriochlorophyll *a* and have the capability to carry out limited anoxygenic photosynthesis (Fleischman and Kramer 1998). Stem-nodulating bacteria will fix N<sub>2</sub> explanta, while bacteria that nodulate roots will fix nitrogen only when growing symbiotically. Other plant species known to have nitrogen-fixing nodules on their stems include *Neptunia*, *Discolobium*, *Cassia*, and *Parkinsonia*. Additionally, under appropriate conditions nodules have been observed on the lower stems of field beans, clover, peanuts, and soybeans. Nitrogen fixed by the bacterium–stem relationship is important for plant growth because the soils where plants are nodulated are nitrogen-deficient. Bacteria associated with nitrogen-fixing nodules on stems are undergoing classification, and a species that nodulates clover stems has more recently been identified as *Methylobacterium nodulans*.

## 7.7 BACTERIA SUPPORTING PLANT GROWTH

### 7.7.1 Production of Hormones

Many rhizospheric microorganisms produce chemicals that stimulate plant growth, and these chemicals have a molecular structure similar to that of plant hormones. As reviewed by Elmerich et al. (1992), many bacteria produce plant-stimulating compounds, including auxins, gibberellins, cytokinins, ethylene, and abscisic acid (see Table 7.5). Additionally, many rhizospheric fungi and numerous rhizospheric bacteria produce the plant hormone ethylene (Arshat and Frankenberger 1992). These plant-like hormones are produced by free-living, symbiotic, and pathogenic strains of rhizospheric microorganisms. While microorganisms use plant hormones to initiate root symbiosis, the benefit from plant hormone production by saprophytic microorganisms is not readily apparent.

### 7.7.2 Growth-Promoting Rhizobacteria

The most numerous microorganisms in the soil are bacteria, and these organisms may influence mycorrhizal growth. Scientists recognize the importance of soil bacteria and have called them *plant-growth-promoting rhizobacteria* (PGPR) or simply *growth-promoting bacteria* (Garbaye 1994; Schippers et al. 1987). Certain bacteria are proposed to support the establishment of a fungus–root relationship, and they are collectively referred to as *mycorrhization helper bacteria* (MHB). Not all bacteria in the soil stimulate mycorrhizae formation, but the organisms most commonly recognized for stimulating it are fluorescent *Pseudomonas*. It appears that metabolic products of bacteria support the establishment of mycorrhizae; however, details of this activity remain unresolved. It is quite likely that some of the same bacteria are being studied in MHB and PGPR systems because fluorescent bacteria of the genus *Pseudomonas* are important in both groups.



TABLE 7.5. Bacterial Production of Plant Hormones

Bacteria	Plant-Associated Activity	Plant-Like Hormone Produced
<i>Agrobacterium tumefaciens</i>	Crown gall in many plants	Auxin
<i>Rhodococcus fascians</i>	Infects plant shoots producing "witch's broom"	Cytokinin
<i>Pseudomonas amygdale</i>	Almond canker	Auxin
<i>Pseudomonas syringae</i>	Bacterial phytopathogen	Auxin
<i>Bradyrhizobium</i> sp.	Nitrogen-fixing symbionts	Auxin
<i>Rhizobium</i> sp.		Auxin
<i>Frankia</i> sp.		Auxin
<i>Azotobacter vinelandii</i>	Soil bacteria	Auxin, gibberellin, cytokinin
<i>Azospirillum brasilense</i>		Auxin, gibberellin, abscissic acid, cytokinin
<i>Methylobacterium mesophylicum</i>	Bacteria growing on plant leaves	Cytokinin
Many bacteria	Rhizospheric growth	Ethylene

Source: Modified from Elmerich et al. (1992).

Several different activities have been attributed to bacterial action decreasing plant growth. One example is the production of cyanide by soil bacteria as they metabolize glycine, serine, methionine, or threonine. The presence of cyanide inhibits mitochondrial energetics in the roots so that the plant growth and/or crop yield may be inhibited by 10–40%. With the addition of PGPR pseudomonads, iron-chelating siderophores are produced and cyanide production is eliminated. The cyanide-producing bacteria do not grow in iron-deficient soils because they are unable to obtain iron from the siderophores produced by the PGPR pseudomonads.

A mixture of several species of microorganisms is more effective in stimulating plant growth than is a monoculture of bacteria or fungi. *Bacillus* species are known to stimulate phosphorus uptake from organophosphate compounds by *Pinus caribaea* containing the ectomycorrhizal fungus *Pisolithus tinctorius*. Several species of soil bacteria, including *Pseudomonas* spp. and *Bacillus megaterium*, produce gibberellin-like phytohormones that promote root growth and stimulate the establishment of mycorrhizae. The nodulation of clover, *Trifolium subterraneum*, by the appropriate rhizobium culture is greatly enhanced if *Pseudomonas putida* and an endomycorrhizal fungi are present. Similar stimulation of colonization by endomycorrhizal fungi occurs with *T. subterraneum* when *Pseudomonas putida* is present. One perplexing observation in soil microbiology is that bacteria in one environment promote plant growth but in another are deleterious for plant growth. Some of those bacteria with dual roles have been identified as *Pseudomonas fluorescens*, *P. putida*, *B. subtilis*, *Klebsiella*, *Enterobacter*, and *Arthrobacter*. Apparently, the strains of the bacteria isolated are as important as the particular bacterial species.

The role of *Beggiatoa*, a filamentous bacterium, in detoxifying the root zone from sulfide is an interesting example of mutualism. Some plants, such as rice and cattails, grow submerged under water where atmospheric gases diffuse slowly into the mud around the roots and anaerobic niches are created. In this mud environment, oxygen-tolerant *Desulfovibrio* use sulfate as the terminal electron acceptor with the production of H<sub>2</sub>S. In this low-oxygen environment, *Beggiatoa* oxidize H<sub>2</sub>S to sulfate with the concomitant production of H<sub>2</sub>O<sub>2</sub> (hydrogen peroxide). The accumulation of H<sub>2</sub>O<sub>2</sub> could become

toxic to *Beggiatoa* because these bacteria lack catalase for the decomposition of  $H_2O_2$ . However, the roots of these aquatic plants secrete catalase to break down  $H_2O_2$  to  $O_2$  and  $H_2O$ . Thus, *Beggiatoa* support the growth of aquatic plants under appropriate situations.

### 7.7.3 Cactus Symbiosis

In the harshest of terrestrial environments, cacti flourish (Figure 7.19), and in at least one situation, bacteria enable cactus to grow. Yoav Bashan observed that cacti were growing in rocks of northern Mexico in an environment where plants were seldom found. He and his colleagues (Puentes et al. 2009) report a cactus–bacteria symbiosis that enables the cholla cactus, *Pachyereus pringlei*, to grow in igneous rocks. The bacteria are found as endophytes of the plant and also are present in the cactus seeds. When the seeds fall on animal dung, the bacteria grow with the production of organic acids that convert rock particles to mineral soil. These endophytic bacteria continue to grow in the roots of the cactus with the continuous secretion of organic acids and fixation of nitrogen. Initial



**Figure 7.19.** A saguaro cactus found in the Sonoran Desert of Southwestern United States (photograph by Larry Barton).

analysis of the sequencing of the 16S rRNA genes of these endophytes indicates that these cactus symbionts are similar to endophytic bacteria found in other plants and are not related to *Pseudomonas*, *Klebsiella*, or *Bacillus*.

## 7.8 LEAF SURFACES AND MICROORGANISMS

The term *phyllosphere* refers to the area of the leaf where various forms of life may be found. The surface of the leaf is an area where various microorganisms (e.g., bryophytes, lichens, fungi, bacteria) may be permanently established (Lindow and Leveau 2002). The most luxurious examples of phyllospheric organisms are found in tropical rainforests. Lichens and bryophytes are not detrimental to the overall photosynthetic response of the plant because they are present only on older leaves. While the leaf provides a surface for lichens and bryophytes to grow, these epiphytes inhibit leaf grazing by snails and leaf-cutter ants. Of considerable importance is the presence of nitrogen-fixing cyanobacteria located between lichen and bryophyte on the leaves. Nitrogen compounds leached from leaves with epiphilic cyanobacteria may contribute over 10% of the nitrogen balance for that environment.

Leaf surfaces represent an important surface for microbial colonization, and it has been estimated that  $10^{26}$  bacteria are present in this habitat (Delmotte et al. 2009). A study of community proteogenomics (Delmotte et al. 2009) revealed that phyllosphere bacteria are predominantly members of the *Sphingomonas*, *Pseudomonas*, and *Methylobacterium* genera (Delmotte et al. 2009). In a metagenome study of three different plant species, archaea contributed only 0.35% to the microbes present, and these were members of the mesophilic Crenarchaeota. Present on young plant leaves of numerous taxonomic groups is a purple-pigmented bacterium identified as *Methylobacterium mesophylicum*. This bacterium is proposed to be an important leaf epiphyte in that it grows on methanol released by the plant and secretes cytokinin, which is a plant hormone (Holland and Polacco 1994). Cytokinin not only stimulates plant growth but also reduces the rate of chlorophyll degradation observed in leaf senescence. Methanol production in plant leaves is released as precursor carbohydrate polymers are condensed to produce the cell wall structure.

A rather curious phenomenon called “ice nucleation” may occur on leaves as a result of the presence of specific strains of *Pseudomonas*, *Erwinia*, or *Xanthomonas*. These bacteria grow on the plant leaves without any harm to the plant but in cold weather they promote the formation of ice crystals. The localized freezing of the leaf results in the release of fluids from the plant cells, and this material provides nutrients for bacterial growth. A specific protein on the surface of the bacterial cell is responsible for the initiation of ice crystal formation (Guyrian-Sherman and Lindow 1993). The formation of ice crystals can be prevented by spraying a mutant of *Pseudomonas syringae* on the leaves. This mutant bacterium lacks the specific protein on the surface of the cells and prevents the initiation of ice crystal formation. The mutant *P. syringae* cells grow and occupy the niche where wild-type bacteria containing the ice nucleation protein would colonize. Thus, damage to the leaf from freezing can be avoided. While the amount of protection provided to the plant is significant, it is limited in that it only enables plants to tolerate temperatures down to 29°F or 30°F.

## 7.9 DETRIMENTAL ACTIVITIES OF MICROORGANISMS ON PLANTS

### 7.9.1 Fungal Parasites

Several fungi and a small number of bacteria are pathogenic for plants. Fungi of all taxonomic classes are capable of causing epidemic plant diseases that produce considerable economic loss and hardship for humans. Examples of plant diseases produced by bacteria and fungi are listed in Table 7.6. Disease-producing fungi may be considered as parasites on plants where the infected plant provides nutrients for fungal growth. Some of the fungi are obligate parasites, while others are facultative with fungal growth also from nutrients in the soil.

The pattern followed for disease formation in plants is generally as follows:

1. Spores or vegetative cells of fungi come in contact with the plant.
2. The fungi penetrates the surface through wounds, stomata, and other openings in the plant cell.

TABLE 7.6. Selected Examples of Microorganisms Pathogenic for Plants

Microorganisms as Pathogens	Plants as Host
<b>Bacteria</b>	
<i>Agrobacterium tumefaciens</i>	Crown gall
<i>Corynebacterium insidiosum</i>	Alfalfa wilt
<i>Corynebacterium michiganense</i>	Canker of tomatoes
<i>Erwinia amylophorus</i>	Apple and pear blight
<i>Pseudomonas solanacearum</i>	Tobacco wilt
<i>Pseudomonas syringae</i>	Canker of stone fruit
<i>Spiroplasma citri</i>	Citrus stubborn and corn stunt
<i>Xanthomonas hyacinthia</i>	Infected hyacinth bulbs
<b>Fungi</b>	
<i>Ceratocystis ulmi</i>	Dutch elm disease
<i>Claviceps purpurea</i>	Ergotism of cereal grains
<i>Cylindrocladium scoparium</i>	Stem and root rot of many plants
<i>Erysiphe graminis</i>	Wheat mildew
<i>Fusarium lycopersici</i>	Tomato wilt
<i>Fusarium solani</i>	Root rot of beans and other plants
<i>Heterobasidion annosum</i>	Root rot in many different conifer species
<i>Melampsora lini</i>	Flax rust
<i>Phytophthora infestans</i>	Potato blight
<i>Plasmodiophora brassicae</i>	Club root of cabbage
<i>Puccinia graminis</i>	Stem rust of grains
<i>Ustilago avenae</i>	Oats
<i>Ustilago maydis</i>	Corn smut
<i>Venturia inaequalis</i>	Apple scab
<i>Verticillium dahliae</i>	Cotton and other plants

TABLE 7.7. Selected Characteristics of Phytopathologies Attributed to Bacteria and Fungi

Hypergrowth	
Club root	Enlargement of root
Leaf curls	Distortion and curling of leaves
Galls	Proliferation of plant tissue that is filled with fungal hyphae
Necrosis	
Blight	Leaves and flower petals turn brown and die
Canker	Infection beneath the surface on a stem produces a slight depression
Damping off	Rapid death of young seedlings
Leaf spots	Localized lesion with dead cells on leaves
Root rot	Root system of a plant decays
Scab	Raised, sunken, or scabby lesions on fruit, tubers, or leaves
Surface or systemic activity	
Mildew	White or gray areas on leaves generally due to mycelium and fungal spores
Rust	Red-brown color on leaves or stems attributed to small lesions
Wilt	Leaves or shoots droop because of a loss of turgidity, attributed to disturbance in root or stem

3. An infection occurs with the fungi growing in either the intracellular or intercellular region.
4. Other tissues are invaded, and the pathogen is spread throughout the plant.
5. Depending on the pathogen, death of the plant may be observed in a few days or a few weeks.

The specific pathologies attributed to various fungal diseases vary with the fungus, and some of the terms used to describe these infections are listed in Table 7.7.

### 7.9.2 Bacterial Pathogens

The bacteria-producing diseases in plants generally display a number of hydrolytic enzymes for penetration of the plant surface, and growth in the plant is generally intercellular between the parenchyma cells. As the disease progresses in the plant, bacterial distribution may become systemic as a result of migration into the vascular tissue. In some cases, the bacteria release pectinase that hydrolyzes the plant cell walls and the plant collapses. In other instances, cells of bacteria may concentrate in the sieve cells and the reduction of flow in the xylem or phloem results in plant death. As a response to the bacterial infection, there is an oxidative burst by the plant to inhibit the invading pathogen (Lamb and Dixon 1997). Successful plant pathogens have several virulence-enhancing factors, including assimilation of iron and the production of superoxide dismutase in response to oxidative response. Dominique Expert has been a pioneer in the study of virulence-associated siderophore production by phytopathogenic bacteria and is highlighted here.

**Microbial Spotlight****DOMINIQUE EXPERT**

Dominique Expert relaxes while attending a scientific meeting in Santiago de Compostella, Spain.—(Photograph courtesy of Larry Barton).

What can a person do with a doctorate degree in biochemistry and molecular biology from the Pasteur Institute in Paris, France? In the case of Dominique Expert, you become Directeur de Recherche at the French National Centre for Scientific Research (CNRS). In this role, she directs the Laboratory of Plant-Pathogen Interactions, which involves three institutions: the National Institute for Research in Agronomy (INRA), the Paris Institute of Technology (AgroParisTech), and the University Paris 6.

In science the journey is often as important as the destination, and Dominique recounts the various topics of her research. "For my doctoral research I selected a challenging project that was to investigate the role of bacteriophages as potential vectors of gene transfer from the bacterium to the plant. This PhD work included characterization of a new temperate bacteriophage that I isolated from the plant pathogen *Agrobacterium tumefaciens*."

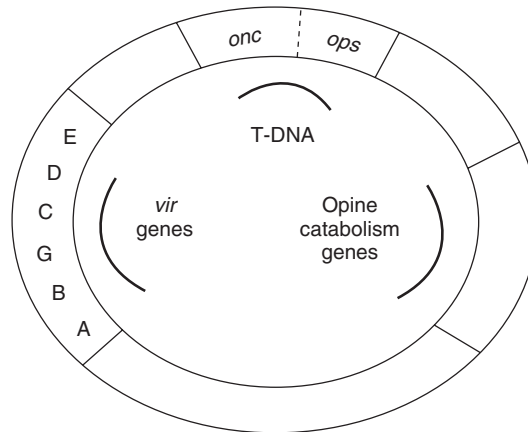


This was significant because at that time, the mechanism by which the oncogenic species *A. tumefaciens* caused the crown gall disease in plants was totally unknown. Most studies in bacterial molecular genetics had been devoted to the *Escherichia coli* model. To further her interest in microbial pathogenicity, she decided to continue her research activities in the field of plant–microbe interactions. She accepted a postdoctoral position in the Department of Molecular Biology at University of Bruxelles (ULB), where she investigated the role of outer-membrane determinants in the pathogenicity of *Erwinia chrysanthemi*. Then it was on to the Department of Plant Pathology of INRA to develop a project on the role of iron in plant pathogenesis. To familiarize herself with siderophore biochemistry that was being developed for bacteria infecting animals, she went to the Biochemistry Department of the University of California at Berkeley to work with Joe Neiland. Then, it was back to the INRA, where her group has made significant contributions in plant pathology by demonstrating the role of siderophores and the importance of control of iron homeostasis in the pathogenicity of *Erwinia*. When asked what gave her the most satisfaction in her professional career, she replied “The research activities of [her] laboratory to characterize molecular mechanisms in plant pathogenesis.”

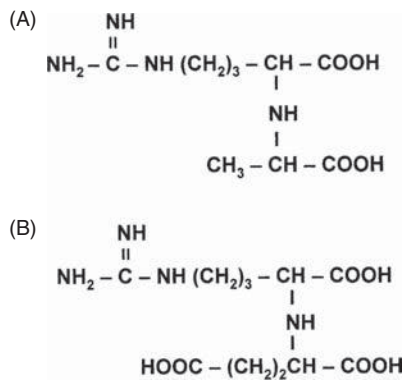
The bacterium *Agrobacterium tumefaciens* produces tumors in a diverse group of dicotyledonous plants at the root–stem interface that is called the “crown” of the plant. Thus, the disease has been called “crown gall.” The microorganism is an aerobic Gram-negative bacterium that is widely distributed in soils where it grows on a variety of sugars and organic acids. The infection is initiated by a wound to the plant that enables bacterial cells to attach to the plant by either pili or capsular material. The *A. tumefaciens* cell does not enter the plant cell; rather, a large plasmid is transferred from the bacterium to the plant. This plasmid is designated as Ti because it is responsible for tumor induction in plants. A model of the Ti plasmid is given in Figure 7.20. The Ti genes are transferred into the plant genome with the production of plant hormones, auxins, and cytokinins. Examples of those compounds produced include octopine and nopaline (see Figure 7.21). The localized stimulation of plant growth at the site of infection by *A. tumefaciens* results in the gall-like growth that may become detrimental because nutrient flow is disrupted.

### 7.9.3 Rhizosphere Activities and Plant Diseases

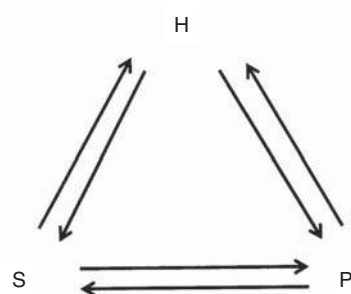
A series of complex relationships in the rhizosphere influence the growth and survival of plant pathogens in the soil. The rhizosphere activities important for plant diseases that have a lifecycle in the soil are summarized in Figure 7.22. While the interaction between the pathogen and roots of the host are relatively obvious, the root exudates of the host are a key component in the infectious process. Cells sloughed from the roots and the root exudates may directly inhibit growth of the pathogens or may stimulate the growth of saprophytic microorganisms that may have an antagonistic effect on the pathogen. Thus, important factors influencing the establishment of a disease process in plants is a reflection of the health of the plant and the extent that the rhizosphere supports a highly diverse microbial population.



**Figure 7.20.** The Ti plasmid of *Agrobacterium tumefaciens*. The T-DNA segment is transferred to the plant host. Tumor-producing genes are the *onc* (oncogenes), and opine synthesis genes are *ops*.



**Figure 7.21.** Structures of plant hormones produced by genes on the Ti plasmid: (A) octopine and (B) nopaline.



**Figure 7.22.** Ecological relationships influencing activity of soil pathogens. The host roots (H) exudates promote the growth of saprophytic soil bacteria. The nonpathogenic soil microorganisms (S) may in some cases inhibit the growth of pathogens, and in other instances the products of S may stimulate the growth of pathogens. The pathogen (P) may be antagonistic on saprophytic microorganisms, or primary pathogen may stimulate the growth of a secondary pathogen.

When replanting trees in peach or apple orchards, an interesting phenomenon that may be observed is soil fatigue or “soil sickness.” The characteristic feature is that it is difficult for newly planted peach trees to grow in an old peach orchard. This is because of the accumulation of prunasine in the roots of peach trees. Bacterial degradation of prunasine results in the release of benzaldehyde and hydrocyanic acid; however, bacteria accounting for this degradation are most active when the peach roots are young. In old orchards, prunasine persists for several years and contributes to phytotoxicity of newly planted peach trees. In the case of replanting apple orchards, phytotoxicity is attributed to phloridzine that accumulates in the older roots. Degradation of phloridzine by soil bacteria releases phloretine, phloroglucinol, *p*-hydroxycinnamic acid, and *p*-hydroxybenzoic acid, which are highly toxic to young apple roots. In the case of older asparagus beds, soil microorganisms release caffeic acid and methylenedioxycinnamic acid from the old roots of asparagus, and these phenolic compounds inhibit the development of mycorrhizal fungi, *Glomus fasciculatum*, on asparagus roots.

In field observations, one may observe the dominance of a single plant species with the growth of other plant types inhibited. For example, exudates from walnut roots will inhibit the growth of apples, tomato, and alfalfa. In these cases, the phytotoxic compounds may include caffeic, cinnamic, coumaric, ferulic, gallic, and vanillic acids. This activity is termed *allelopathy*, and in the broadest description this phytotoxic effect is attributed to production of root exudates or decomposition of the dominant plant. Allelopathy is not well characterized in the literature, and the role of rhizospheric organisms in the contribution of phenolic compounds is unresolved. Certainly, the reduction of phenolic compounds with time is attributed to the metabolism of rhizospheric microorganisms.

## 7.10 FUNGI PROMOTING INCREASED HEAT TOLERANCE IN PLANTS

A three-way symbiotic system has resulted in increasing the thermal resistance of certain green plants. When the fungus *Curvularia protuberate* infects *Dichantheilum lanuginosum*, a tropical grass, the plant is capable of growing in soil that has a temperature of 65°C. However, for this heat tolerance, the fungus must also be infected with a dsRNA virus consisting of two segments, and this virus has been designated as *Curvularia thermal tolerance virus* (CThTV) (Márguez et al. 2007). This physiological response in plants is not restricted to infected monocots because increased thermal tolerance of tomato, *Solanum lycopersicon*, occurs when plants are infected by the *Curvularia* fungus carrying CThTV. This novel three-way symbiosis provides a unique perspective on mutualism found in the ecosystem.

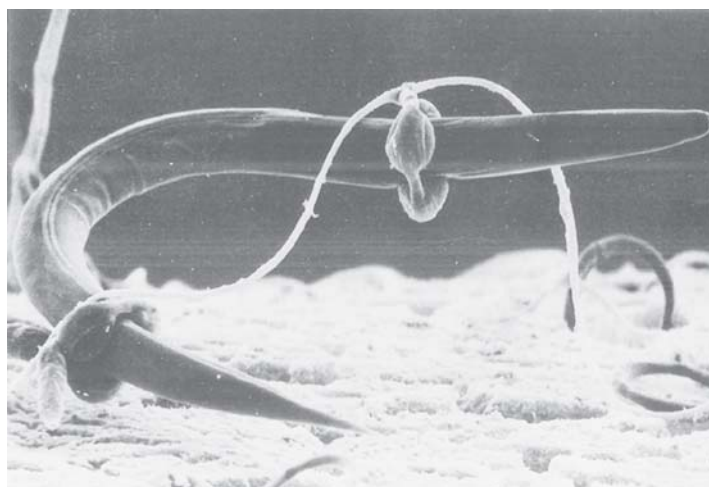
## 7.11 BIOCONTROL OF PESTS AND PATHOGENS

Throughout time, the control of insects and agents responsible for disease production in plants has been achieved through the use of chemicals. However, an increased concern for the addition of chemicals into the environment has prompted scientists to explore the use of biological agents to control or prevent the growth of pathogens.

Plant-growth-promoting rhizobacteria (PGPR) produce a variety of antibiotic compounds that inhibit a variety of Gram-negative and Gram-positive soil bacteria, including some that may be phytopathogenic. In one case, antibiotic synthesis by growth-promoting pseudomonads results in the production of pyoluteorin and 2,4-diacetylphloroglucinol, which are effective against pathogenic fungus such as *Pythium ultimum*. The application of certain strains of *Pseudomonas* to fields growing potatoes has been helpful in increasing the yield of potatoes. It has been proposed that bacteria produce siderophores that sequester iron in the environment and pathogenic fungi are unable to acquire iron for growth.

Nematodes found in the soil are roundworms of a few millimeters in length, and some of these are parasitic for plants. As a result of nematodes attacking roots and underground parts of the plant, death of the plant may be due to direct damage by the nematode or to secondary infection by bacteria, fungi, or viruses. As reviewed by Barron and Thorne (1987), fungi may be obligate or facultative parasites for nematodes. The trapping of nematodes by fungi may be attributed to the fungi having adhesive hyphae or constricting rings to hold the nematode with digestion of the nematode attributed to enzymes released from the fungus. An electron micrograph showing a nematode-trapping fungus is given in Figure 7.23. With the obligate endoparasitic fungi, the fungal spores may be ingested by nematodes or attach to the nematode surface and grow. Examples of fungi parasitic for nematodes are given in Table 7.8. These predaceous fungi serve as a natural control of soil nematodes, and management of this antagonistic potential is an important biological control for nematodes infecting plants.

There is a fungus, *Cordyceps* sp., which is parasitic on insects, arthropods, and caterpillars feeding on vegetables. This infection of a large number of hosts is attributed to the fact that there are about 300 different species of *Cordyceps*. It has been proposed that strains of this Ascomycete would be effective in tropical regions for biological control of insect pests. One species of this fungus, *C. sinensis*, was named “caterpillar fungus”



**Figure 7.23.** Scanning electron microscope observations of a nematode trapped by the predatory fungus *Arthrobotrys anchonia*. (Photograph from *Ward's Natural Science* used with permission).

TABLE 7.8. Examples of Fungi Parasitic on Nematodes

Feeding Habit of Fungus	Name of Fungus
Adhesive surface of hyphae that form a trap for the nematode	<i>Arthrobotrys oligospora</i> <i>Monacrosporium cionopagum</i>
Formation of constricting rings	<i>Arthrobotrys conoides</i>
Attack the egg stage of nematode	<i>Fusarium</i> sp.
Endoparasitic fungi ingested by nematode or penetrating cuticle of nematodes	<i>Harposporium anguillulae</i> <i>Catenaria anguillule</i>

TABLE 7.9. Examples of Insects Susceptible to  $\delta$ -Endotoxins Produced by *Bacillus thuringiensis*

Subspecies of <i>Bacillus thuringiensis</i>	Host Range
<i>B. thuringiensis kurstaki</i>	Lepidoptera (e.g., <i>Heliothis virescens</i> )
<i>B. thuringiensis thuringiensis</i>	Lepidoptera (e.g., <i>Pieris brassicae</i> )
<i>B. thuringiensis morrisoni</i>	Diptera (e.g., <i>Aedes aegypti</i> and black flies)
<i>B. thuringiensis san diego</i>	Coleoptera (e.g., Colorado potato beetle)
<i>B. thuringiensis tolworthi</i>	Coleoptera (e.g., <i>Spodoptera exigua</i> )

by the ancient Chinese because of the appearance of the fruiting body of the fungus. *Codryceps sinensis* grows in high altitudes of Asia and is highly valued because of its pharmacological uses.

Certain strains of *Bacillus thuringiensis* produce a protein that has been used to control insect populations and some of the insects controlled are listed in Table 7.9. *Bacillus thuringiensis* is an aerobic, Gram-positive bacterium found broadly distributed in soil. In 1911, Ernst Berliner discovered that this bacterium produced a disease in flour moth caterpillars. *Bacillus thuringiensis* produces an inactive protoxin located in the cytoplasm of the bacterium near the developing endospore and, therefore, is often referred to a *parasporal body*. Insect larvae ingest the bacterial cells along with other dietary materials and proteases in the midgut of the larvae release  $\delta$ -endotoxin (Cry toxin) from the protoxin (Chattopadhyay et al 2004). This endotoxin creates pores in the membranes of the epithelial cells lining the midgut, and this leads to death of the larvae. There are over 50 different *cry* genes encoding protoxin production, and most of these appear to be on plasmids. As indicated in Table 7.9, toxic activities of the various subspecies *B. thuringiensis* may be specific for lepidoptera (moths and butterflies), diptera (flies and mosquitoes), or coleoptera (beetles). Resistance of diamondback moth larvae to the effects of *B. thuringiensis* has been tentatively attributed to lack a specific protease to modify the protoxin to  $\delta$ -endotoxin. In commercial applications, bacteria have been grown in the laboratory and dried before being dusted on plants. The Bt toxin is frequently marketed as Thuricide or Dipel. Through DNA recombinant activities, genes for protoxin production have been introduced into plants, and the resulting transgenic plants would have increased resistance to attack by insect larvae. In 2000, about 20% of the genetically modified crops had received the Bt gene, and these plants are frequently considered as being environmentally friendly with little potential harm to humans, animals, beneficial insects, and other plants in the region.

## 7.12 SUMMARY

A diverse group of microorganisms are found in the root zone rhizosphere, and bacteria present in the rhizoplane have considerable influence on the plant. Under certain conditions, specific bacteria may enhance plant growth, due to the development of mycorrhizae, or prevent growth of phytopathogenic fungi. Fungi may be found in symbiotic association with plant roots, where the plant provides sugars and organic acids while the fungus partner enhances mineral uptake by plants. The two principal types of fungal association are endomycorrhizae found commonly on herbaceous plants, and ectomycorrhizae, which are generally associated with woody plants. Symbiotic nitrogen-fixing plants have specific bacteria as partners for the conversion of atmospheric  $N_2$  to ammonia. These bacteria generally colonize the plant roots, and two major groups exist: rhizobia with leguminous plants and *Frankia* with specific woody plants. In lower plants, cyanobacteria are the nitrogen-fixing partner. A large number of phenotypic changes occur as the bacteria are transformed from free-living in soil to plant symbionts. Establishing the plant–bacteria activity results from signal responses on the part of both partners in this symbiosis. A few of the fungi and bacteria are plant pathogens producing highly distinctive plant pathologies. An important bacterial disease in plants is crown gall attributed to *Agrobacterium tumefaciens*, with invasion usually into the plant root. Unique in this infection is the presence of a Ti plasmid in the bacterium, and this specific plasmid carries genes for plant hormones to stimulate tissue proliferation.

## 7.13 DELVING DEEPER: CRITICAL THINKING QUESTIONS

1. Define or describe each of the following terms:

Cyanobionts	Nod factors
Endosymbionts	Hartig net
Rhizoplane	Ti plasmids
Rhizosphere	Phyllosphere

2. Describe the contribution of each partners in the (a) lichen and (b) mycorrhizae symbiosis systems.
3. Describe the events leading to the establishment of crown gall disease.
4. Describe the general process of nodule formation by rhizobia.
5. Some have suggested that mycorrhizal activity is an example of controlled parasitism. Do you agree? Defend your answer.
6. List as many activities as you can that would indicate that soil bacteria are important in supporting plant growth.
7. Clearly it would be more efficient for nitrogen-fixing plants to acquire the relevant genes from bacteria than to have bacteria growing in close association with plants. List some difficulties that would be confronted by plants and fungi if they were to acquire appropriate genes from the environment and not utilize symbiotic bacteria for nitrogen fixation.
8. What are some examples of bacteria being used to control plant pests?



## BIBLIOGRAPHIC MATERIAL

## Further Reading

- Barton LL, Johnson GV, Bishop YM (2006), The metabolism of iron by nitrogen-fixing rhizospheric bacteria, in Barton LL, Abadía J, eds., *Iron Nutrition in Plants and Rhizospheric Microorganisms*, Dordrecht: Springer, pp. 199–214.
- Expert D (1999), Withholding and exchanging iron: Interactions between *Erwinia* spp. and their plant hosts, *Annu. Rev. Plant Pathol.* **37**:307–334.
- Glare TR, O’Callaghan M (2000), *Bacillus thuringiensis: Biology, Ecology and Safety*, Chichester, UK: Wiley.
- Jones DL (1998), Organic acids in the rhizosphere—a critical review, *Plant Soil* **205**:25–44.
- Kasuge T, Nester EW (1989), *Plant-Microbe Interactions. Molecular and Genetic Perspectives*, Vol. 3, New York: McGraw-Hill, pp. 457–504.
- Lynch JM (1990), *The Rhizosphere*, New York: Wiley.
- Makerji KG, Monoharachary C, Singh J, eds. (2006), *Microbial Activity in the Rhizosphere*, Heidelberg: Springer.
- Prell J, Poole P (2006), Metabolic changes of rhizobia in legume nodules, *Trends Microbiol.* **14**:161–168.
- Waisel Y, Eshel A, Kafkafi U (1996), *Plant Root: The Hidden Half*, 2nd ed., New York: Marcel Dekker.

## Cited References

- Adams DG (2000), Symbiotic interactions, in Whitton BA, Potts M, eds., *The Ecology of Cyanobacteria*, Dordrecht: Kluwer Academic Publishers, pp. 523–561.
- Adl SM (2003), *The Ecology of Soil Decomposition*, Cambridge, MA: CABI Publishing.
- Arshat M, Frankenberger WT Jr (1992), Microbial biosynthesis of ethylene and its influence on plant growth, *Adv. Microbial Ecol.* **12**:69–111.
- Barron GL, Thorne RG (1987), Destruction of nematode species of *Pleurotus*, *Can. J. Botany* **65**:774–778.
- Chattopadhyay A, Bhatnagar NB, Bhatnagar R (2004), Bacterial insecticidal toxins, *Crit. Rev. Microbiol.* **30**:3–54.
- Davet P (2004), *Microbial Ecology of the Soil and Plant Growth*, Plymouth, UK: Science Publishers.
- Delmotte N, Knief C, Chaffron S, Innerebner G, Roschitzki B, Schlapbach R, von Mering C, Vorholt JA (2009), Community proteogenomics reveals insight into the physiology of phyllosphere bacteria, *Proc. Natl. Acad. Sci. (USA)* **106**:16428–16433.
- Elmerich C, Zimmer W, Vieille C (1992), Associative nitrogen-fixing bacteria, in Stacey G, Burris RH, Evans HJ, eds., *Biological Nitrogen Fixation*, London: Chapman & Hall, pp. 212–258.
- Fleischman D, Kramer D (1998), Photosynthetic rhizobia, *Biochim. Biophys. Acta—Bioenergetics* **1364**:17–36.
- Garbaye J (1994), Helper bacteria: A new dimension to the mycorrhizal symbiosis, *New Phytol.* **128**:941–943.
- Guyrian-Sherman D, Lindow SE (1993), Bacterial ice nucleation: Significance and molecular basis, *FASEB J.* **7**:1338–1343.
- Holland MA, Polacco JC (1994), PPFMs and other covert contaminants: Is there more to plant physiology than just plants? *Annu. Rev. Plant Physiol. Molec. Biol.* **45**:197–209.

- Lamb C, Dixon RA (1997), The oxidative burst in plant disease resistance, *Annu. Rev. Plant Biol.* **48**:251–275.
- Lindow SE, Leveau JH (2002), Phyllosphere microbiology, *Current Opin. Biotechnol.* **13**:238–243.
- Lynch D, O'Brien J, Welch T, Clarke P, Cuív P, Crosa JH, O'Connell M (2001), Genetic organization of the region encoding regulation, biosynthesis, and transport of rhizobactin 1021, a siderophore produced by *Sinorhizobium meliloti*, *J. Bacteriol.*, **183**:2576–2585.
- Márquez LM, Redman RS, Rodriguez RJ, Roossinck MJ (2007), A virus in a fungus in a plant: Three way symbiosis required for thermal tolerance, *Science* **315**:513–515.
- Puente ME, Li CY, Bashan T (2009), Rock-degrading endophytic bacteria in cacti, *Environ. Exper. Botany* **66**:389–401.
- Rai AN, Bergman B, Rasmussen U, eds. (2002), *Cyanobacteria in Symbiosis*, Dordrecht: Kluwer Academic Publishers.
- Schippers B, Bakker AW, Bakker PAHM (1987), Interactions of deleterious and beneficial rhizosphere microorganisms and the effect of cropping practices, *Annu. Rev. Phytopathol.* **25**:339–358.
- Schwintzer CR, Tjepkema JD (1990), *The Biology of Frankia and Actinomycorrhizal Plants*, New York: Academic Press.
- Simard SW, Perry DA, Jones MD, Myrold DD, Durall DM, Molina R (1997), Net transfer of carbon between ectomycorrhizal tree species in the field, *Nature* **388**:579–582.
- Vessey JK, Pawlowski K, Bergmann B (2005), Root based N<sub>2</sub> fixing symbiosis: Legumes, actinorrhizal plants, *Parasponia* sp and cycads, *Plant Soil* **275**:51–78.
- Viguier C, O Cuív P, Clarke P, O'Connell M (2005), RirA is the iron response regulator of the rhizobactin 1021 biosynthesis and transport genes in *Sinorhizobium meliloti* 2011, *FEMS Microbiol. Lett.* **246**:235–242.
- Yanagita T (1990), *Natural Microbial Communities*, Berlin: Springer-Verlag.

---

# INTERACTIONS BETWEEN MICROORGANISMS AND ANIMALS

---

## 8.1 CENTRAL THEMES

- Bacteria and fungi interact with humans and other animals.
- Animal–microbial symbioses can be mutualistic, commensalistic, or parasitic.
- Symbiotic relationships are widespread.
- Symbiosis has led, through evolutionary processes, to new metabolic capabilities and cellular structures.
- Symbioses between animals and microorganisms led to the origin of mitochondria and chloroplasts.
- Specific examples of symbioses covered in this chapter include:
  - Fungi are essential for the nutritional support of specific beetles.
  - Bacteria support the growth and nutrition of numerous insects.
  - Bacteria may influence sex development in insects.
  - Symbiotic association occurs between squid and fish with bioluminescent bacteria.
  - Several examples illustrate the benefit for birds and ruminants to host specific bacteria.

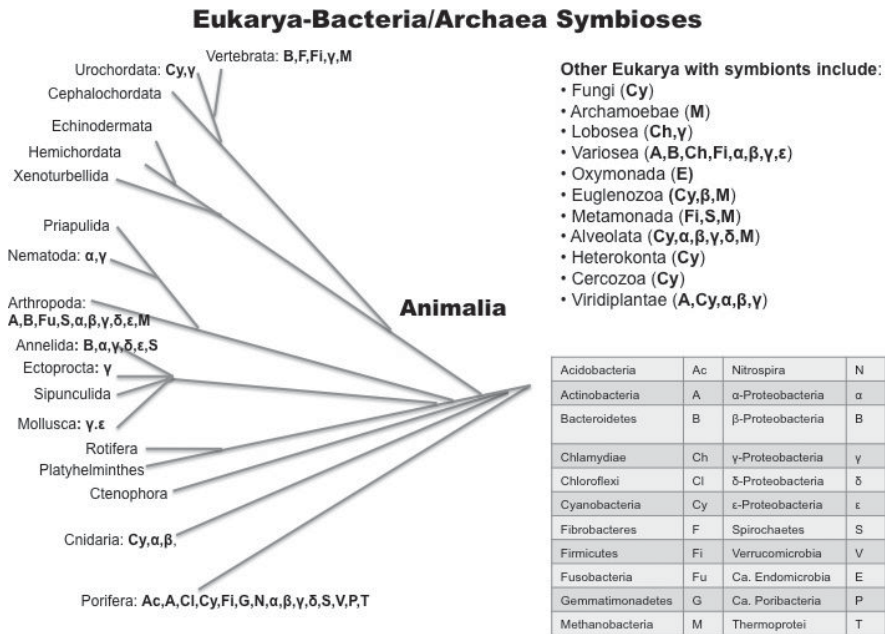
## 8.2 INTRODUCTION

Animal–microbial symbioses involving many types of animals (Figure 8.1) are widespread across the tree of life (Figure 8.2) and have arisen independently many times. Look at Figure 8.2; what groups within the tree have the most symbionts? Which bacterial or archaeal groups seem to occur the most often as symbionts? One of the interesting things you may notice is that the Cyanobacteria and the different divisions of the Proteobacteria have formed symbioses throughout the tree. In these symbiotic relationships, evolution has often led to the development of new metabolic capabilities or cellular structures. For example, the origin and evolution of the eukaryotic cell is intimately tied to a symbiosis between an alphaproteobacterial organism and a eukaryotic cell.

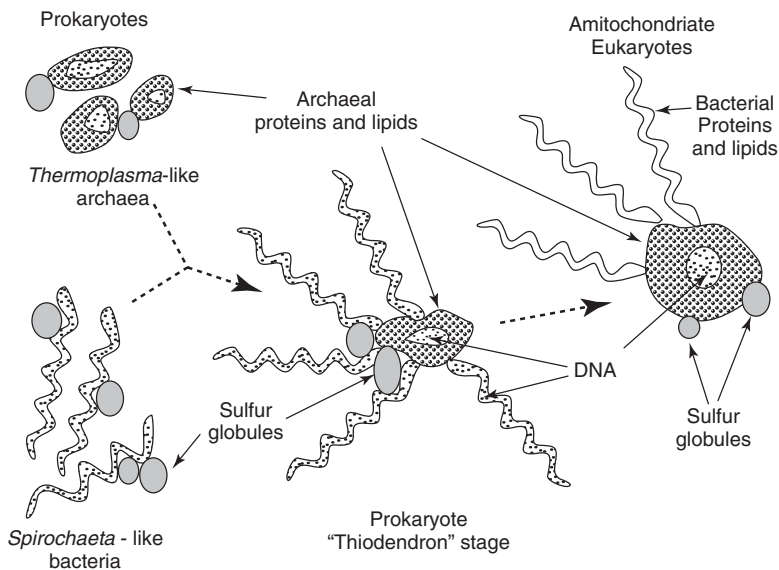
Symbiogenesis occurs when new physiological processes, new tissues, or new organs evolve as a result of a symbiotic relationship (Margulis and Chapman 1998). The theory of endosymbiosis, built on the early work of Konstantin Mereschkowsky and Andreas Schimper, was developed and popularized by Lynn Margulis (see the “microbial spotlight” in this chapter). These researchers started from the observation that both chloroplasts and mitochondria share resemblances with bacteria. Margulis based her hypotheses on her studies of extant microbiology, which included living analogs from the microbial



**Figure 8.1.** Animals of various types may have symbiotic relationships with specific microorganisms. (Images courtesy of Kenneth Ingham.) See insert for color representation.



**Figure 8.2.** Moya et al. (2008) have provided an overview of the eukaryotic divisions within which we have documented symbioses with various bacteria and archaea. The upper part of the figure shows the entire Eukarya branch of the tree of life, with an enlarged view of the Animalia portion of this tree. The letters by each division denote which bacterial or archaeal divisions have been documented as forming symbiotic relationships within that eukaryotic division. [Modified from Moya et al. (2008).]



**Figure 8.3.** Flowchart illustrating the Margulis theory of the origin of the eukaryotic cell [adapted from Margulis et al. (2000).]

world. She put forth the hypothesis (Margulis 1993) that this union developed from an early sulfur-associated archaeobacterium, such as the extant *Thermoplasma*, which lives in sulfur environments, with a spirochete-like swimming ancestor (Figure 8.3). These two organism types formed a *Thiodendron*-like consortium (an anaerobic sulfur syntrophy of two different bacterial species found in a slimy matrix) that merged their genomes, membranes, and protein into a chimeric nucleus (Margulis et al. 2000). Phylogenetic evidence shows that mitochondrion and chloroplast DNA resemble that of Alphaproteobacteria and Cyanobacteria, bolstering the endosymbiosis theory of the origin of the eukaryotic cell.

Margulis has extended her hypotheses to suggest that symbiosis, particularly symbiogenesis, drives evolution. As you read through this chapter, note the many ways in which symbiotic relationships have resulted in evolutionary changes.

### ***Microbial Spotlight***

#### **LYNN MARGULIS**



Lynn Margulis in Carlsbad Cavern, New Mexico.—(Photograph courtesy of K. Ingham, copyright 2008).

Lynn Margulis always wanted to study the evolution of life forms, and her studies of non-Mendelian genetics at the University of California at Berkeley allowed her to examine evolution in more detail: “I found whisky and cigarettes, poker and bridge, meetings and politics, gossip and golf, unbearably boring. I, on the other hand, was insufferably bookish, serious, and studious and preferred the company of babies, mud, trees, fossils, puppies, and microbes to the normal world of adults. I still do” (Margulis 1998).

Key influences in her life were her husband, the astronomer Carl Sagan, who made her realize “that we weak little chickens could do science . . . and didn’t have to get it from an authority,” and her course of studies at the University of Chicago, where she learned to forge a union between science and philosophy through her reading of the original writings of scientific giants. Her reading led her to a eureka moment in which she realized “that if chloroplasts were from cyanobacteria and mitochondria were from oxygen-respiring bacteria, analogous data made it incontrovertible that cilia cortical patterns must have been derived from free swimming bacteria.” She read H. F. Copeland’s description of protists that were so “beset with spirochetes that they had been mistaken for supernumerary cilia” and it became clear to her that the free-living ancestor to the cilia should be sought among the spirochetes. Her most important message: “You don’t listen to what people tell you is true—you go find out for yourself.”

Symbiotic relationships can be commensal, mutualistic, or parasitic depending on the effects on the partners in the relationship. In commensalism one partner benefits, while the other neither benefits nor is harmed; in mutualism both partners benefit; and in parasitism one partner is harmed while the other benefits. As in the plant–microbe interactions discussed in Chapter 7, animal–microbe interactions can be endosymbiotic or ectosymbiotic depending on their physical location, and they may be obligate or facultative. Sometimes symbionts that live on the surface of an animal are called *episymbionts*. What do you think the evolutionary benefits are in a symbiotic relationship? Some of the benefits include

- Provision of important dietary needs that their hosts lack, including essential amino acids, cofactors and metabolic factors, and vitamins
- Nitrogen storage and recycling

These factors, especially the exchange of nutritional substances, appear to be the primary driving force for the symbioses (Moya et al. 2008). Others (Lombardo 2008) have argued that the horizontal transmission of endosymbionts may have influenced the evolution of sociality in animals. In horizontal transmission, endosymbionts are transferred from one individual of the host species to another or even to other species, in contrast to vertical transmission, where transmission is from the mother to the egg or embryo. Because endosymbionts can protect their hosts from pathogens, there may be increased interaction among individuals of a population in order to acquire endosymbionts.

Metagenomic studies (see Section 5.9) have allowed us to peer inside these evolving symbioses by examining differences in the genomes of newly acquired symbiotic lifestyles and those of long-established symbiotic relationships. Two findings have emerged from this comparison (Moya et al. 2008): (1) genome size reduction and (2) increase in AT content in the genome. Much less is known at the genes level about how



the animal host adapts to the endosymbiont setting up housekeeping in its cells. What is known about the host's adaptation to the endosymbionts includes the modification of its immune response to the endosymbiont, the creation of methods for controlling populations of the bacteria, and the formation of specialized cells in which the bacteria reside (Moya et al. 2008). Which genes do you think will be lost and which will be retained in the bacterial endosymbiont?

As might be expected, core genes involved in DNA replication, transcription, and translation are retained, as well as genes that code for protein translocation and chaperones. When you think about what genes might be lost over time, think about the environment in which the bacteria now find themselves—it's very stable compared to that often experienced by free-living bacteria. The presence of other endosymbionts may also affect gene loss. Comparisons of endosymbiont genomes reveal the loss of genes for DNA repair, regulation of transcription, nutrient transport, and some metabolic pathways, and a simplification of the cell envelope. Additional details can be found in Moya et al. (2008). When a host cell is invaded by an additional bacterium, a stable consortium may result with each endosymbiont providing some nutrients to the host, or the original symbiont may further reduce its genome and eventually become extinct. Genomic studies are revealing many of the details of facultative and obligate endosymbioses.

### 8.3 PRIMARY AND SECONDARY SYMBIONTS

There are two major types of symbiosis: primary and secondary. In symbioses that occur between insects and microorganisms, these take the following forms (Siozios et al. 2008):

1. Primary symbionts that are transmitted maternally and that live in the bacteriome. A bacteriome is a specialized organelle in insects that hosts bacterial endosymbionts.
2. Secondary symbionts that can be transmitted horizontally to new hosts, in addition to the usual maternal transmission.

Primary symbionts have a long evolutionary history with their host and are viewed primarily as a mutualism in which they provide their host with “goodies” such as vitamins and other nutrients. If one examines molecular phylogenetic trees of primary symbionts and their hosts, you see a great deal of correspondence between host and symbiont phylogenetic trees, supporting the idea of very old codiversifications, which can range from 30 to 270 million years ago (Dale and Moran 2006). Large alterations in genomes of the symbionts and adaptations by the host to favor the symbiosis occur during this long association. Two examples of primary symbionts are *Buchnera aphidicola* and *Wigglesworthia glossinidia*. Both genera have been the subject of whole-genome sequencing and show marked genome reduction. Primary symbiont genomes are often under one megabase as opposed to the genome size of *E. coli*, whose genome is roughly five megabases (5 Mb). The resultant genomes of primary symbionts show commitment to a symbiotic lifestyle, relying on their hosts. One of the more fascinating findings from the whole genomes of primary symbionts is that 10–14% of the genes relate to host nutrition. This is in opposition to parasite genomes, which have eliminated genes related to amino acid biosynthesis. Additional discussion of symbiont genome reduction can be found in Dale and Moran (2006).

Secondary symbionts, on the other hand, may negatively or positively affect the host, and are generally facultative in nature. *Wolbachia pipientis* (see Section 8.4.4) represents an example of a secondary symbiont. Dale and Moran (2006) suggest that the genomes of facultative symbionts indicate that these organisms are just beginning the process of adapting to an obligate mutualistic lifestyle from their free-living lifestyle. Some facultative symbionts such as *Wolbachia* have genomes of size intermediate between those of primary symbionts and free-living bacteria.

An important consequence of the study of host–symbiont interactions and the genetics underlying these associations is the light being shed on the evolution of pathogenetic mechanisms. Dale and Moran (2006) suggest that pathogenetic mechanisms, such as systems for protein secretion, evolved in the ancient symbiotic associations with invertebrates and then moved to vertebrates.

## 8.4 MICROBE–ANIMAL INTERACTIONS: PARASITISM

So, naturalists observe, a flea—Hath smaller fleas that on him prey; and these have smaller still to bite'em; and so proceed ad infinitum.

—Jonathan Swift

### 8.4.1 Parasitism Introduction

Parasitism involves interactions in which one organism (the parasite) benefits from the other organism (the host), while either harming or killing its host. Parasites are mostly unicellular and are often highly adapted to carrying out their key functions of colonizing a host, evading the host's immune system, and eventually transmitting to a new host. Richard Dawkins offered the view that parasitism is just a way for the DNA of a parasitic organism to replicate its DNA at the expense of the host's DNA [reported in Zimmer (2003)]. Parasitic interactions are widespread throughout the tree of life, and we'll examine examples that range from clear-cut to ones that have parasitic and mutualistic aspects.

### 8.4.2 Nematode Parasitism of Insects

Parasitic interactions can be quite complex and can be linked to other symbiotic relationships. One fascinating parasitic interaction involves nematodes that parasitize insects. These nematodes harbor a bacterial endosymbiont, *Photorhabdus luminescens*, which plays a key role in the nematode parasitism of the insect host. One particular nematode, *Heterorhabditis bacteriophora*, has been studied as a model organism to help us understand human and insect parasitism by nematodes (Hallem et al. 2007). Some *Heterorhabditis* arrest their development in a phase called an *infective juvenile larval stage*; *Photorhabdus luminescens* infects the larval nematode at this stage. Once the *Heterorhabditis* infects the host insect, they undergo a renewed development due to signals from the insect's hemolymph. As part of this development the infective juvenile larvae disgorge the *Photorhabdus luminescens*, which secretes proteases and other compounds that help suppress the insect's immune system and damage the insect. The nematode parasite feeds on both the former bacterial endosymbiont and the insect host. Hallem et al. (2007) were

able to show that the *Photorhabdus luminescens* are key to the immune response by the insect (in this case *Drosophila*) and to mortality of the host. In this example, the parasite (the nematode) is intimately linked to an endosymbiont that both serves as prey and facilitates the nematode's parasitism of its insect host. The role of *Photorhabdus luminescens* in changing the host environment and in stimulating a host immune response is just one example of the variety of instances in which microbiomes have been shown to affect parasite infection of hosts (Azambuja et al. 2005). Such an immune response can lead to the production of compounds by the host that limit pathogens and their infection of the host. Azambuja et al. (2005) suggest that such bacterial gut residents may produce a variety of cytotoxic compounds with anti-parasitic characteristics, such as pigments (e.g., prodigiosin), hemolysins, antibiotics, metalloproteases, and hemagglutinins.

### 8.4.3 Effects of Multiple Parasitic Infections on Virulence

Another facet of parasitism is the impact of multiple parasitic infections on the overall virulence (defined as “disease-induced mortality of the host”) of the infections. For example, humans infected with the HIV virus can survive longer if coinfecting with the flavivirus GB virus C and bacteria that produce bacteriocins as defenses against other bacteria, which can actually result in lower virulence by coinfecting, unrelated bacteria [reviewed in Alizon (2008)]. This is an active area of research, and a new model by Alizon (2008) suggests that when multiple strains coinfect hosts, lower virulence results and highly virulent strains are able to emerge and persist because of the lowered virulence. Other areas of research into coinfection include the examination of coinfection by bacteriophages. These interactions can be mutualistic or parasitic, in which viruses compete for resources within the host cell or one virus may even parasitize another virus (Turner 2003).

### 8.4.4 A Widespread Endosymbiosis: *Wolbachia*—Parasitism or Mutualism?

*Wolbachia pipientis* has been described as “one of the most successful intracellular symbionts yet described” (Iturbe-Ormaetxe and O'Neill 2007) and as “probably the most ubiquitous endosymbiont on the planet” (Siozios et al. 2008). This Alphaproteobacteria is a Gram-negative, bacillus-like- or coccoid-shaped, bacterium in the Rickettsiaceae family that is maternally and horizontally transmitted, and obligately intracellular. It lives within a host vacuole in the host's cytoplasm. Different studies estimate that *Wolbachia*'s infection of insects ranges from 20% to 75%. Beside insects, studies report infection of mites, spiders, nematodes, and terrestrial crustaceans (Iturbe-Ormaetxe and O'Neill 2007). *Wolbachia*'s success has been attributed to its manipulation of the reproduction of its host through

- Killing male offspring
- Inducing parthenogenesis
- Phenotypically converting males to females (feminization)
- Modifying of the host's male gametes so that an incompatibility exists with females that are not infected with the same strain of *Wolbachia*, leading to zygote lethality (termed “cytoplasmic incompatibility”)

Besides these more deleterious effects on the host, there also have been beneficial effects such as those seen in nematodes and wasps, where *Wolbachia* is important for normal development of the host and its eggs, viability, and fertility. These studies have changed the traditional view of *Wolbachia* as a reproductive parasite to demonstrate that *Wolbachia* species also perform as more traditional mutualists. Thus, it appears that *Wolbachia* can be a “good bug” or a “bad bug.” Some of the cellular mechanisms employed by *Wolbachia* in both its beneficial and deleterious roles, as well as the mechanisms it uses to escape the host’s immune system are explored in Iturbe-Ormaetxe and O’Neill (2007).

Much remains to be learned about the interactions of *Wolbachia* with its host, which several genomics studies currently underway will begin to elucidate. These studies have the potential to reap important benefits in other studies. The *Wolbachia* symbiosis is important not only because of its widespread nature but also because of the light it may shed on speciation and insect control methodologies that may result from study of *Wolbachia*’s manipulation of its host.

## 8.5 MICROBE–ANIMAL INTERACTIONS: MUTUALISM

An interaction in which both parties benefit is called *mutualism*. The animal world abounds with examples in which animals and microorganisms live together in a mutualistic relationship (Table 8.1). The studies we present here are currently viewed as beneficial relationships, but just as we saw in the study of *Wolbachia*, these interactions may yet reveal other aspects, some of which may be deleterious. We will begin with some of the most famous examples of mutualism—those that occur in the guts of insects, such as termites and cockroaches, or ruminants. These examples illustrate the critically important roles that the symbionts play in the nutrition of their hosts.

### 8.5.1 Gut Animal–Microbe Mutualistic Interactions

Some of the most famous examples of microbial gut communities come from the insect world, such as those associated with termites and cockroaches. As in vertebrates, gut microbial communities produce vitamins needed by their hosts; help digest food more efficiently, especially where the food is of lower quality; and control the invasion of pathogenic bacteria (Dillon and Dillon 2004). Different kinds of insect guts rely to varying degrees on microbial symbionts. These range from little dependence on microorganisms in those insects that possess the so-called “straight tube” (what we humans have) to much greater dependence in insects such as termites that have a rumen-type gut. The microbial community composition also changes in response to diet changes. While the cockroach may not be your favorite critter, studies of their gut microbial communities have revealed that a switch to higher-fiber, low-protein diet causes a decrease particularly in bacterial groups, while an increase in cellulose leads to an upsurge in the protozoal populations (Dillon and Dillon 2004). These changes probably contribute to increased efficiency in relation to the dietary changes.

One beneficial function of gut microbiota for which you can thank your gut microbes is “colonization resistance,” which keeps nonnative bacteria from colonizing the host’s gut. The mechanics of colonization resistance can be complex and involve such factors

TABLE 8.1. Selected Examples of Interactions between Animals and Microorganisms

Animal Host	Microbial Mutualism	Interaction
Ruminants (e.g., sheep, deer, cattle, camels)	Hundreds of species of bacteria, fungi, and ciliate protozoa	Degradation of plant matter with production of vitamins and growth factors, including volatile fatty acids (acetic, propionic, and butyric acids).
Medicinal leech ( <i>Hirudo medicinalis</i> )	<i>Aeromonas veronii</i> <sup>a</sup> <i>Rikenella</i> -like bacterium	Digestive tract symbiosis; extracellular location of symbiont.
Hawaiian squid ( <i>Euprymna scolopes</i> )	<i>Vibrio fischeri</i> <sup>a</sup>	Light organ symbiosis and functions to produce light to camouflage squid.
Aphids ( <i>Aphidoidea</i> )	<i>Buchnera</i> sp. <sup>a</sup>	Nutritional symbiosis for amino acid synthesis; intracellular location of symbiont.
Soil nematode ( <i>Steinernema carpocapsae</i> )	<i>Xenorhabdus nematophilus</i> <sup>a</sup>	Digestive tract symbiosis.
Termite ( <i>Macrotermes</i> )	<i>Termitomyces</i> sp. <sup>b</sup>	Fungi produce cellulases to degrade plant matter, and termite consumes both plant matter and fungi.
Wood wasp ( <i>Sirex cyaneus</i> )	<i>Amylostereum</i> sp. <sup>b</sup>	Fungus produces cellulases and xylanases to degrade plant matter to feed the offspring from the wasp eggs.
Marine nematode ( <i>Eubostrichus parasitiferus</i> )	Crescent-shaped bacteria	Bacteria are attached on the exterior of the nematode; the nematode feed on bacteria and carry these chemolithotrophic bacteria into areas of reduced sulfur zones.
Marine polychaete ( <i>Osedax</i> sp.)	<i>Oceanospirillales</i> <sup>a</sup> in bones	As endosymbionts, bacteria digest organic matter.
Ambrosia beetles	Various fungi	Beetles cultivate fungal gardens in bark and feed on the fungal mass.
Mealybugs	Various bacteria	Endosymbionts provide amino acids for bugs.
Worms of hydrothermal vents ( <i>Riftia pachyptila</i> )	Bacteria	Endosymbionts are chemolithotrophic bacteria that usually obtain energy from oxidization of sulfide.

<sup>a</sup>Bacterial species.

<sup>b</sup>Fungal species.

as the production of antimicrobial compounds, such as phenolics, to which indigenous microorganisms are immune, and competition for resources (Dillon and Dillon 2004).

Interactions between the gut microbiota and the host extend to the plants and animals on which the host feeds. For example, Dillon and Dillon (2004) report on a study of ant lion larvae in which a mutualistic bacterium produces a compound that paralyzes the larvae's prey. Other studies reveal the insect gut as an ideal habitat in which bacteria exchange genes, with implications for many other fields. Insect gut microbiota studies are rapidly expanding to include genetic exchange, host immune response, and new roles for microorganisms living in insect guts.

**Termite Gut Communities: Symbioses Within Symbioses.** Terrestrial ecosystems depend on the “lower” termites for their ability to decompose lignocellulose, which is due to their microbial gut community. This gut community contains bacteria that provide the host with nutrients and flagellated protists that break down cellulose. These well-studied communities have been slow to reveal their secrets because of our inability to culture many of the microorganisms and the lack of functional information that single-gene studies provide. Endogenous cellulases work together with those produced by protists to degrade cellulose. The protists have also been shown to anaerobically produce hydrogen in special organelles called *hydrogenosomes* (Ohkuma 2008).

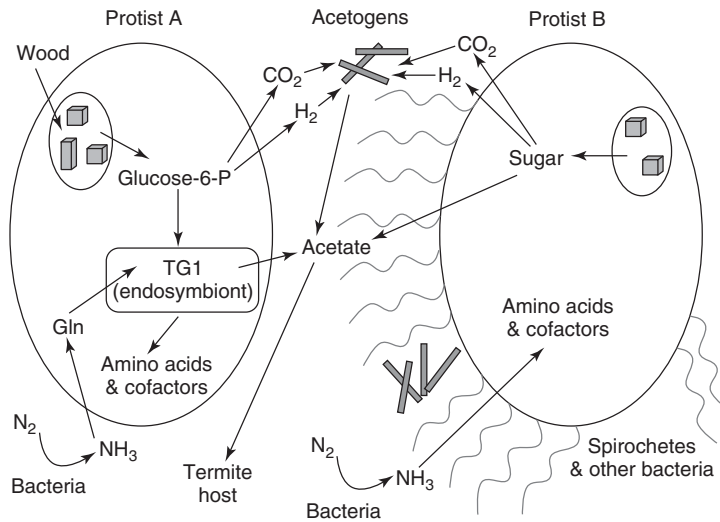
Molecular phylogenetic studies of the bacterial communities present in the gut of the lower termite *Reticulitermes speratus* reveal a diverse community, in which the dominant Spirochaetes together with a new candidate phylum, termite group 1 (TG1), Bacteroidetes, and Firmicutes make up approximately 80% of the bacterial community in the gut. The most startling finding is that greater than 90% of the gut bacterial phylotypes are new and have no close relatives (Ohkuma 2008). This has led to the proposal of three new phyla: TG1, TG2, and TG3. While this novelty is fascinating, the problem is that we know little about the function of these new bacterial groups. The complexity of the termite gut is truly amazing. The protist endosymbionts have their own endosymbionts and ectosymbionts, often with more than one symbiotic species associated with a given protist. These bacterial and archaeal symbionts of the protists include Spirochaetes (*Treponema*), Bacteroidales, *Methanobrevibacter* (methanogens in the Archaea), Synergistes (Gram-negative anaerobes in a relatively new division of the bacteria), and TG1 bacteria (Ohkuma 2008). These associations between protists and bacteria/archaeal species can be quite specific. Termite gut protists are often covered with thousands of ectosymbionts, sometimes even giving the protists motility (also termed *symbiosis motility*). Examples of symbiosis motility exist in different bacteria, which Ohkuma (2008) suggests indicates evolutionary convergence. The importance of protists and their ecto- and endosymbionts for gut metabolism is suggested by the numerical dominance in the gut.

What does the termite get from these bacterial and archaeal inhabitants that find homes in the termite gut? Protists and their symbionts play critical roles in termite nutrition. Figure 8.4 illustrates the steps in which protists engulf woode particles containing cellulose and ferment these to hydrogen, carbon dioxide, and acetate. One of the intermediates of this process, glucose-6-phosphate (G6P), is used by TG1 endosymbionts, while a variety of acetogens, including some spirochetes, produce acetate from the carbon dioxide and hydrogen products of the wood degradation. This acetate is the major energy and carbon source for the host termite! Several of the bacteria symbionts of the protists in the termite gut provide amino acids and cofactors to the host protists. Nitrogen-fixing bacteria in the termite gut provide nitrogen-containing compounds to the protists and the host termite. Wood, which is predominantly lignocellulose, does not provide the needed nitrogen compounds, making the role of the TG1 endosymbionts in providing nitrogen compounds critical. Altogether, this is a pretty amazing community with many interactions. If you want to get really excited by microbiology, read more about this amazing ecosystem.

### 8.5.2 Case Study: Unique Bacterial–Polychaete Endosymbiosis

Tiny males living inside female tubes and a unique heterotrophic bacterial degradation role tell a fascinating tale of animal–microbe interaction (Rouse et al. 2004). This very unusual association exists between rod-shaped bacteria in the Oceanospirillales and newly



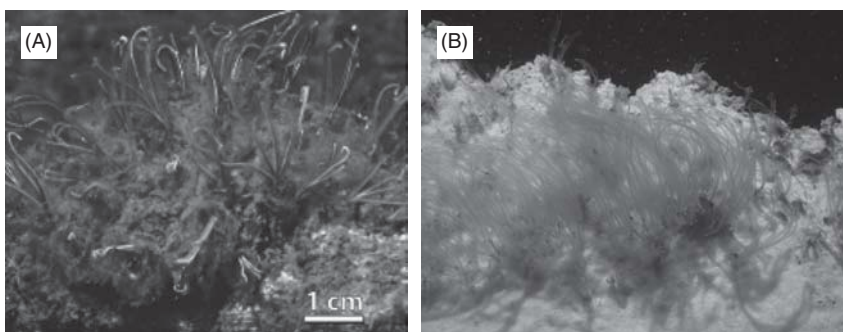


**Figure 8.4.** Protists and their associated ecto- and endosymbionts pay important roles in termite gut metabolism [modified from Ohkuma (2008)]. See insert for color representation.

described species of *Osedax*, polychaete worms in the family Siboglinidae. The *Osedax* spp. “feed” on organic compounds in whale bones through a vascularized system of root-like appendages that emerge from a posterior ovisac to penetrate the bone marrow (Figure 8.5). The bacteria reside in the sheath that covers the ovisac and root-like protrusions. What makes this association more unusual is the bacterial heterotrophic degradation of organic compounds found in the bones of the whales. Most deep-sea endosymbionts rely on methane or sulfide and are chemolithoautotrophic. The bacterial endosymbionts are the source of food for the polychaete worms.

### 8.5.3 Case Study: Beetles Cultivating Fungal Gardens

Not all mutualisms need to be endosymbiotic. There is an interesting symbiotic relationship between ambrosia beetles and fungi, where the beetles cultivate fungal



**Figure 8.5.** (A) *Osedax frankpressi* from 2983 m depth (B) *Osedax roseus* from 1820 m depth. (Images courtesy of R.C. Vrijenhoek, Monterey Bay Aquarium Research Institute.)



gardens (Paine et al. 1997). The beetle carries the fungi into a new environment where the fungi flourish, and uses the fungi as food. Depending on the species, beetles may tunnel into the xylem of dying trees or the phloem of healthy trees. Spores of the fungal symbiont are introduced into the tunnels by the beetles and as the fungal mycelium grows it penetrates the plant tissues. These fungi do not digest cellulose, and the sawdust resulting from the beetle activity is released from the tunnel opening. The adult beetles and beetle larvae feed on the fungal spores and mycelium lining the tunnels. As the adult beetle leaves one tree to infect another, it carries fungal spores into the new tunnel. If the ambrosia fungi associated with the bark beetles tunneling into the phloem are phytopathogens, the tree may quickly die and forests may be at risk. This beetle–fungus symbiosis is considered to be the result of convergent evolution because of the diversity of partnerships established. There are about 3000 different species of beetles that can be partners in the fungal ambrosial growth form. The fungal group is also large, and it appears that these fungi are found almost exclusively in association with beetles. Most of the ambrosia fungi are Ascomycetes, and commonly encountered genera include *Ambrosiella*, *Dryadomyces*, and *Rafaella*.

#### 8.5.4 Mealybug Mutualisms

If you've ever grown houseplants, chances are you have dealt with mealybugs, those plant pests that secrete a cottony substance around their bodies, making your plants appear to be festooned with miniature cotton balls. Knowing what causes these insect pests to thrive may give us avenues for controlling them, a potentially economically important solution that motivates scientists to study this symbiosis. Several studies have revealed that mealybugs are inhabited by not just primary endosymbionts but also secondary endosymbionts that live within the cytoplasm of the primary endosymbionts, an unusual arrangement (Thao et al. 2008). In some insects, primary endosymbionts may supply key amino acids to hosts, which would be useful to mealybugs who feed on plant phloem, which is rich in carbohydrates, but lacking in essential amino acids. These studies illuminate transmission of endosymbionts and suggest that the primary endosymbionts are vertically transmitted and have formed a stable relationship with their immediate hosts, which can reveal the taxonomy of their insect hosts. The primary endosymbionts of mealybugs reside within the Betaproteobacteria, and their tight phylogenetic association with their hosts suggests a single infection of the common ancestor of modern mealybug hosts. The secondary endosymbionts, which form several clades within the Gammaproteobacteria, appear to have infected the primary endosymbionts several times, suggesting several evolutionary origins. For example, the citrus mealybugs that consume sap (phloem) from pineapples have been extensively studied and have been found to contain both bacterial groups as endosymbionts (Kono et al. 2008). These bacteria are found in the *symbiotic sphere* or bacteriome, which is an oval structure taking up half of the insect abdomen. Using DNA analysis, it has been determined that the bacteria present are from both the Betaproteobacteria and Gammaproteobacteria groups. The latter has been found to be phylogenetically different enough to warrant a separate designation, *Candidatus Tremblaya princeps*. The gammaproteobacteria provide nutrients to the betaproteobacteria, and the betaproteobacteria provide nutrients to the mealybug. These proteobacteria are found in the bacteriocytes, which are specialized cells within the bacteriome in the insect's body cavity, and usually there are about a half-dozen betaproteobacteria and several gammaproteobacteria. Sequence analysis of bacterial RNA suggests that Betaproteobacteria were the

original symbionts established millions of years ago and more recently, the Gammaproteobacteria became associated with the mealybug. The vertical passage of bacteria to insect is in embryo development, where specialized cells acquire the proteobacteria that may be released from adjacent cells. This gammaproteobacterial endosymbiosis currently represents the only non-eukaryotic endocellular symbiosis known. Additionally, the Betaproteobacteria primary endosymbionts are unusual insect symbionts, as most insect primary endosymbionts reside within the Gammaproteobacteria. This unique association has the potential to shed light on the key processes that led to the rise of eukaryotic cells, including the origin of endocytosis and how one bacterial cell engulfs another.

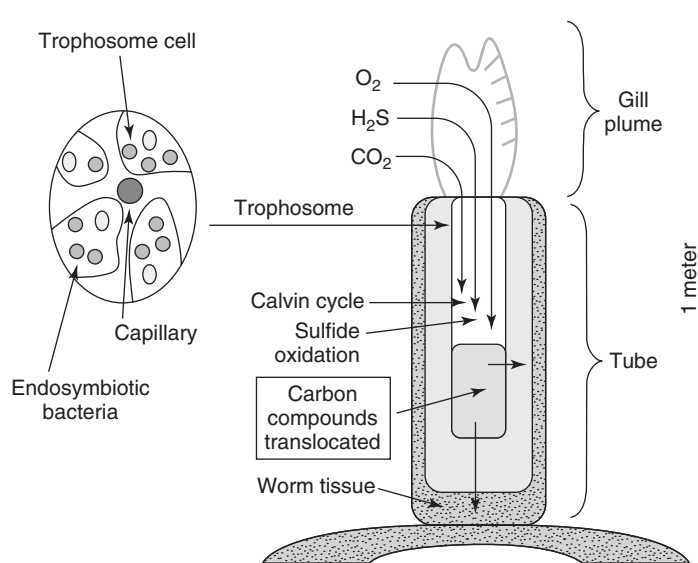
In addition to the more common role of providing nutrients to hosts, some symbionts provide unique services, such as bioluminescence, that can assist hosts in escaping predation or attracting mates or prey.

### 8.5.5 Luminescent Bacteria in Fish and Squid: Turning on the Lights

*Vibrio fischeri* bacteria live in the light organs of squid and fish in the ocean in a symbiotic relationship. Bacterial luminescence helps their squid hosts escape predation through counterillumination or helps fish hosts attract mates; in return, symbionts obtain shelter and nutrients from the host. Luminescence is governed by quorum sensing (see additional information in Section 9.5). *Vibrio fischeri* produces *N*-acylhomoserine lactone (AHL), a small-signaling molecule (see Figure 3.22) termed an *autoinducer* that is released into the surrounding water when the bacteria are free-living, where it is diluted. When the bacteria are sheltered within a squid or fish host, the AHL accumulates as bacterial population densities increase, leading to the binding and activation of LuxR, a transcriptional activator. Subsequently LuxR binds to the lux box, causing enhanced production of luciferase enzymes and other chemicals key to bioluminescence and voilà! The lights come on.

## 8.6 LESSONS FROM THE DEEP: EVOLUTIONARY AND ECOSYSTEM INSIGHTS FROM DEEP-SEA VENTS SYMBIOSES

Consider this: Deep-sea hydrothermal vents were discovered relatively recently, in 1977. The exciting part of this find was the extensive community of living organisms, large and small, that exists at these oases on the ocean floor. Deep-sea vent communities were the first multicellular animal ecosystems based on microbial chemoautotrophy to be found. The reduced or absent digestive system in several of the vent animals, such as *Riftia pachyptila*, represented a riveting puzzle as to how they “fed,” until the discovery of their endosymbionts (Figure 8.6). A gill plume that is about 20 cm is present at the anterior end of the tube worm. Molecular oxygen, carbon dioxide, and hydrogen sulfide are absorbed by hemoglobin that circulates through the gills. Hemoglobin transports these substrates through capillaries to cells in the trophosome that are present in the trunk of the tube worm. Bacteria grow in the cytoplasm of the trophosome cell. Using sulfide oxidation to provide energy, the chemolithotrophic bacteria convert carbon dioxide to reduced carbon compounds, and these compounds are used by the tube worm to support tissue growth. Sulfate, a product of sulfide oxidation, is released into the environment, where bacteria will reduce sulfate to sulfide.



**Figure 8.6.** A model of *Riftia pachytila* bacterial symbiosis.

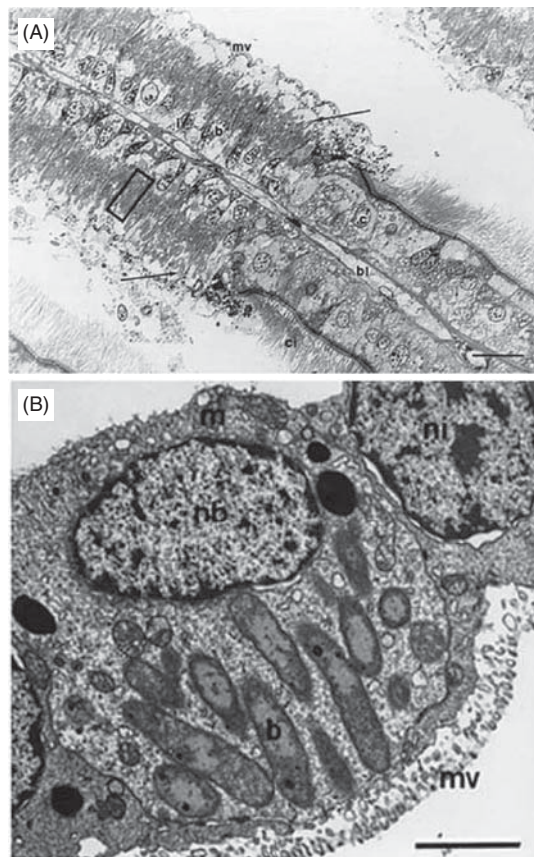
Since deep-sea vent discovery, we have learned more and more details of the fascinating life that lives at deep-sea vents, including symbionts of the equally intriguing animal life that inhabits these ecosystems that occur where there is active seafloor spreading on the midoceanic ridges (Van Dover et al. 2002). These endosymbionts have scientific names that give clues as to their mode of metabolism: *Nitratifactor*, *Sulfurovum*, *Thioreductor*, *Hydrogenimonas*, *Halothiobacillus*, and *Thiomicrospira*. In general, endosymbionts at deep-sea vents fall within the Gammaproteobacteria, while most episymbionts and some endosymbionts fall within the Epsilonproteobacteria. Nakagawa and Takai (2008) classify the Gammaproteobacteria symbionts into four major groups:

1. Endosymbionts of the mussels (*Bathymodiolus*) and clams (*Calyptogena*), which oxidize sulfur (clade I)
2. Endosymbionts of the gastropods (*Alviniconcha*), which oxidize sulfur (clade II)
3. Endosymbionts of the gastropods and tubeworms, which oxidize sulfur (clade III)
4. Endosymbionts of *Bathymodiolus*, which oxidize methane (clade IV)

One of the intriguing things that Nakagawa and Takai (2008) discuss is that two species of *Bathymodiolus* contain both clade I and II species of endosymbiont, which suggests these symbioses occurred more than once and independently. *Bathymodiolus* transmits its endosymbionts horizontally as opposed to the clams of the genus *Calyptogena*, which transmit their endosymbionts vertically.

*Solemya* spp., species in a genus of clams that occurs in sulfide-rich deep-sea vents as well as in shallow-water environments, harbor endosymbionts within their cells. Solemyid chemoautotrophic bacterial endosymbionts, which are transmitted vertically, fix inorganic carbon for themselves and their host, using energy gained by oxidizing reduced sulfur compounds, and help with the detoxification of sulfide for their host. *Solemya velum*, in

particular, is considered to be a model system for studying endosymbiosis as it relies almost entirely on its symbionts for food (Stewart and Cavanaugh 2006). In adapting to the symbiotic relationship, *Solemya* species have reduced their digestive systems substantially and have increased the size of their gills, where the endosymbionts live in specialized cells called *bacteriocytes* (see Figure 8.7). Increased gill size may help endosymbionts gain access to key substances such as hydrogen sulfide, which diffuses across the gills. In addition to fixing carbon via the Calvin cycle, to meet the nitrogen demands of both partners, ammonia is assimilated either by the host in the case of *Solemya velum* or putatively by the symbiont in *Solemya reidi*. This and many other details of the symbiosis are reviewed in Stewart and Cavanaugh (2006). Evolutionarily, the solemyid symbionts provide an interesting puzzle. Because symbionts are found in all members of the family, researchers speculate that symbiosis is an ancestral condition



**Figure 8.7.** Sections of gill tissue showing intracellular symbionts of *Solemya*. *Solemya borealis* with intracellular bacteria indicated at the arrow. A. A light micrograph of a traverse section of the gill of *S. borealis* showing the bacteria at the arrow. B. The image is an electron micrograph showing Gram-negative bacteria within the animal cells of *S. velum*. Bar = 0.5 microns; bl is blood space; b is bacterium; mv is microvilli of the gill surface; n is the nucleus of the animal cell; cl is the cilia. Micrographs provided by Colleen Cavanaugh. For an action video of *Solemya* burrowing in sand see <http://www.youtube.com/watch?v=cJzf5RH7gt0>.

in this ancient lineage of clams. However, sequencing of endosymbionts from the extant solemyid clams reveals some scatter across the phylogenetic tree and the endosymbiont sequences do not form a monophyletic group.

Why do the vent fauna and their symbionts occur in the vent habitats that they do? Studies suggest that geologic setting and geochemistry are important in determining which vent animals are where (Van Dover et al. 2002). Additional abiotic factors such as temperature, pH, redox conditions, and nutrient concentrations help determine which symbionts occur in which habitats.

Studies of the genomes of the host and symbionts are leading to many exciting discoveries and enhanced understanding of the host–symbiont relationship.

## 8.7 MICROBIAL–VERTEBRATE INTERACTIONS

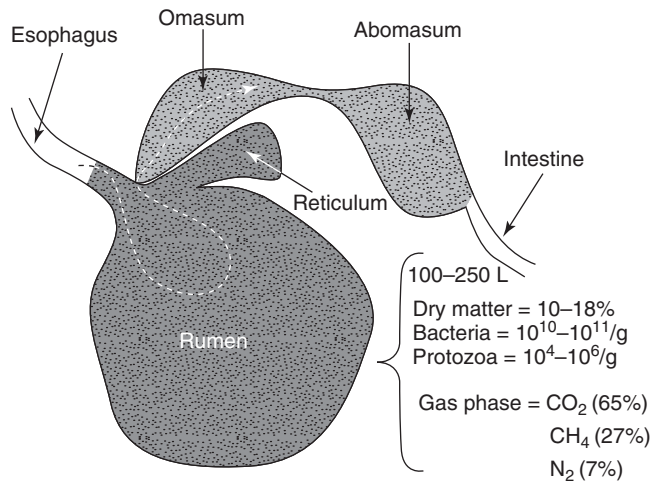
Do the patterns we've discussed in the preceding sections that deal with invertebrate–microbe interactions hold when we turn our discussion to vertebrates? What can an examination of these interactions tell us about evolution?

***Ruminant Gut Microbial Communities.*** In addition to the previous discussion of arthropod gut microbial communities, much can be learned from the study of gut communities of vertebrates. *Ruminants* are animals such as sheep and cows (Figure 8.8) that have stomachs with multiple compartments (Figure 8.9), the first of which is termed the *rumen*. These animals digest their food—often tough grasses with a lot of lignocellulose—several times, and the rumen acts as a fermentation vat. This highly successful mode of life is due to the microbial community associated with the rumen. Kamra (2005) reports on a staggering number of microorganisms in the rumen:



**Figure 8.8.** Watusi calves are an example of ruminants with a multichamber stomach (photo by Larry Barton).





**Figure 8.9.** The stomach of ruminants has four chambers, with the rumen and reticulum making up one division and the omasum and abomasum (a true stomach) the second division. Only the abomasum secretes digestive enzymes, and digestion continues as the food is carried into the intestine. The flow of food materials is shown along the dotted line. See insert for color representation.

(1)  $10^{10}$ – $10^{11}$  cells  $\text{mL}^{-1}$  from >50 genera of bacteria, (2)  $10^3$ – $10^5$  zoospores  $\text{mL}^{-1}$  from five genera of fungi, (3)  $10^4$ – $10^6$   $\text{mL}^{-1}$  from 25 genera of ciliate protozoa, and (4)  $10^8$ – $10^9$   $\text{mL}^{-1}$  of bacteriophages. Because this ecosystem is anoxic, the microorganisms present are anaerobes, which have also adapted to a diet high in lignins, tannins, saponins, and other compounds produced by plants to make them less digestible. The mostly obligate anaerobic bacteria are predominantly Gram-negative, and live optimally at pH 6.0–6.9 at warm temperatures (roughly 39°C). Several members of the *Clostridia* family Ruminococcaceae have been found in the rumen and are believed to be cellulose degraders. In particular, *Fibrobacter* and *Ruminococcus* are two bacterial genera that are key cellulose degraders (Wallace 2008). Several genera of methanogens inhabit the rumen, often attached to the protozoa, and utilize molecular hydrogen generated during fermentation. In addition, several other groups occur in the rumen, including protein degraders, acetogenic bacteria, and tannin degraders (Kamra 2005). Notice some of the parallels with the termite gut.

The *Synergistes*, mentioned above in reference to the termite gut, can be particularly important in ruminant guts, where it was discovered that *Synergistes jonesii* metabolizes a toxic plant compound that could cause serious harm to ruminants who ingest legumes containing mimosine. *Synergistes jonesii* was actually discovered when researchers were trying to discover why ruminants in some countries did not suffer the mimosine toxicity seen in other countries [reviewed in Wallace (2008)]. Kamra (2005) divides the rumen-inhabiting ciliate protozoa into “soluble sugar utilizers, starch degraders and lignocellulose hydrolyzers.” Overlap among the ciliates inhabiting different ruminants occurs at the genus level, but differences occur at the species level. Anaerobic fungi occur in the rumen gut and are believed to contribute to the enzymatic degradation of lignocellulose (Kamra 2005). Large numbers of bacteriophages play a role in lysing various bacterial

species, which may make amino acids available to the host, as well as kill detrimental bacterial species.

***Mammalian Gut Microbial Communities.*** An ambitious analysis of the gut communities of 60 mammalian species, including humans by Ley et al. (2008), revealed coevolutionary and convergent evolutionary trends. These analyses allow us to look back into the evolution of these gut communities and to infer what evolutionary factors shaped the modern-day gut communities. Diet and host phylogeny appear to play a major role in shaping these mammalian gut communities. Herbivorous host animals have the most diverse communities of microorganisms (14 phyla), followed by omnivores (12 phyla), and finally, by carnivores (six phyla). Early mammals were probably carnivores, but the phylogenetic evidence suggests that herbivorous mammals obtained their microbial communities from the environment and not from ancestral carnivorous mammals. Making the change to a herbivorous lifestyle was a significant change for mammals that opened up many new environmental niches, leading to herbivory as the dominant dietary style in mammals. Herbivorous mammals further adapted by changing their gut morphology to allow for microbial fermentation in either the foregut (e.g., sheep) or the hindgut (e.g., horses). The analyses by Ley et al. (2008) show that the gut microbial communities cluster into hindgut or foregut communities. When you examine the bacterial 16S phylogenies, you find that the bacterial communities appear to codiversify with their mammalian hosts.

These findings allow us to understand what drives evolutionary change and support the suggestion that a change in diet can lead to new species. Microbial gut communities play an important role in host adaptation to the new diet. These analyses also reveal the diversity and composition of mammalian gut communities, showing that the Firmicutes dominate with 65.7% of the sequences, followed by the Bacteroidetes (16.3%), Proteobacteria (8.8%), Actinobacteria (4.7%), and Verrucomicrobia (2.2%). Other groups occur with less than 1% of the total sequences each: Fusobacteria, Spirochaetes, DSS1, Fibrobacteres, TM7, Cyanobacteria, Planctomycetes, Deferribacteres, Lentisphaerae, Chloroflexi, and Deinococcus-Thermus. Studies of human gut microbial communities have led to the suggestion that our microbes may play a role in determining whether we're fat or thin.

### 8.7.1 Bacteria and Birds

The hoatzin, or *Opisthocomus hoazin*, is a rare bird in terms of its digestive habits, in terms of both what it eats (leaves) and its use of microorganisms to digest its food. What's odd is that this small bird (less than a kilogram in weight) retains its food for as long a period as some ruminants do and produces a similar amount of fermentation products. To do this in a bird this size requires some anatomical adaptations, including an extended foregut in the hoatzin. Most foregut fermenters are much larger than the hoatzin and are not avian. Godoy-Vitorino et al. (2008) suggest that the hoatzin has taken this evolutionary path in order to exploit a niche not exploited by other birds, only a few of which are folivores, and most mammals. Their study of the hoatzin's foregut microbiota revealed that this gut habitat is dominated by Firmicutes (67%) with additional OTUs in the Bacteroidetes (30%) and Proteobacteria (1.8%) (Godoy-Vitorino et al. 2008). Interestingly, the investigators did not find any of the major cellulolytic organisms found in ruminant guts, but did discover many unclassified sequences (<95% identity to other known sequences). This suggests that hemicellulose (more common in the young leaves and buds



of the hoatzin diet) digestion is more important in this gut community and that the nature of the hoatzin metabolic activities remains to be discovered. This more unique case study illustrates the interesting ways in which evolution shapes microbe–animal interactions.

### 8.7.2 Microorganisms and Humans

Although we humans may find the cockroach and termite guts interesting, we are more fascinated by what lives in our own guts. As with our insect and ruminant friends, gut microbiota help us extract calories from what would otherwise be undigestible food for us. There's also new evidence that the microbial composition of the gut may be linked to obesity, with more obese organisms showing a major decrease in Bacteroidetes and a significant increase in Firmicutes (Ley et al. 2005, 2006). This change in some individuals leads to gut microbiota that facilitate the extraction and storage of energy from an individual's diet. So, what do we know about human gut communities?

For decades, microbiologists thought that Bacteroidetes dominated in the human gut and talked about the presence of *E. coli*, but this knowledge was a product of culturing using standard media available at the time. Recombinant RNA SSU studies (see Section 5.6) gave a much clearer picture of the microbiota of the human gut in the 1990s and the 2000s and revealed that Firmicutes dominated, with the presence of many fewer Bacteroidetes and relatively few Gammaproteobacteria, which contains *E. coli* (Wallace 2008). On the archaeal front, two methanogens have been revealed as colonizers of the human gut: *Methanobrevibacter smithii* and *Methanosphaera stadtmanae*. Their role appears to be the removal of hydrogen generated by other microorganisms to prevent the inhibition of NADH (a reduced form of the electron carrier nicotinamide adenine dinucleotide) by the buildup of hydrogen. Their complete genomes are revealing insights into how they colonize and persist in the gut (Walker 2007).

Your gut microbiota are likely to differ from mine, and we both have many novel species waiting to be described. Additionally, human guts show parallels with ruminant guts (or rumen), showing a dominance of Firmicutes (Wallace 2008). These conclusions parallel those seen in the network analysis done by Ley et al. (2008), who concluded that human gut communities are very similar to those of other omnivorous primates, despite differences among human subjects.

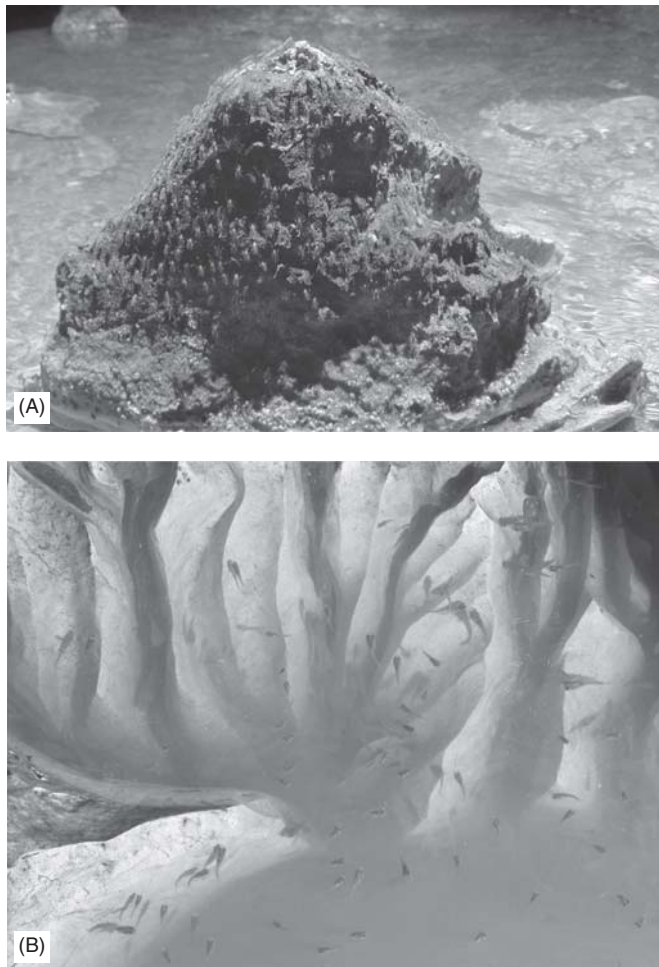
While the species that make up these gut communities are interesting, the functions that they perform are even more critical to our understanding of the nature of microbe–human interactions. Li and colleagues (2008) frame their functional metagenomics research in the context of humans as “superorganisms” that cometabolize with their gut microbiota. Human gut communities can influence how individual humans respond to drugs, what diseases they are more susceptible to, and how they metabolize their food [“metabolic phenotype” (Li et al. 2008)]. However, this is only a beginning; Walker (2007) stated: “As far as diversity of the human gut microbiota is concerned, we have only scratched the surface.”

The human gut is an exciting frontier of research, with much remaining to be discovered.

## 8.8 GRAZING AND PREDATION BY ANIMALS

Microorganisms constitute choice food sources for a variety of herbivorous animals who graze on them. One unusual grazing example occurs in Cueva de las Sardinias in Tabasco,

Mexico, where grazing by several animal species can be observed. Cave mollies (*Poecilia mexicana*) feed on sulfur bacteria in the stream that runs through the cave and midges (*Tendipes fulvipilus* Rempell), and their larvae feed on bacterial biofilms in total darkness (Figure 8.10). Microorganisms form a key part of the food web in this cave system, and grazing may help structure the microbial communities of this system. Studies of microbial grazing have concentrated on grazing of algae and fungi by organisms such as collembola, mites, and nematodes. Grazing (and grazing resistance) is influenced by the shape of the organisms being grazed, how rapidly they grow, their palatability, and whether they are prostrate or upright. The effect of grazing on microorganisms can be multifold and complex, and can be negative or positive in its outcome. Stronger grazing can eliminate species from the habitat, at least temporarily, leading to a change in species abundance patterns. We'll now look at some studies of the different effects of grazing on microorganisms.



**Figure 8.10.** (A) Midges feed on a green bacterial biofilm in total darkness in Cueva de las Sardinias, Tabasco, Mexico; (B) *Poecilia mexicana*, cave mollies, feed on sulfur bacteria in the stream in Cueva de las Sardinias. (Photos courtesy of Kenneth Ingham.)

Fungi are the target of many grazing studies that reveal the details of grazing impacts. Important animal groups that feed on fungi in soils and leaf litter include members of the Arthropoda (especially Collembola and Acari, which include mites and ticks) and Annelida, segmented worms such as earthworms (Enchytraeida), and Nematoda, unsegmented worms (also known as roundworms). These fungivores (fungi-eating organisms) can engulf the microorganism or feed on microbial fluids. Grazing intensities result in different outcomes. Low-level grazing can prune older growth of fungal mycelia, with resulting stimulation of new growth, making grazing a positive impact. Studies show that grazing at a certain level can lead to increased species richness and/or relative abundance, but at very high levels of grazing, species richness will decrease [reviewed in McGonigle (2007)]. Grazing can also shift the balance of power in a community to a formerly non-dominant species, while limiting previously dominant species. McGonigle (2007) also reviews studies that suggest that selective grazing can lead to the replacement of early successional stage fungi by later successional stage fungi. Overall, the outcome for fungi will depend on how strong the grazing is (strong grazing may eliminate some species), how selective grazing is on the basis of grazer food preferences, and the response of the fungi to the grazing.

Moving up the scale in size of herbivores, Hori et al. (2006) showed that birds consume larger species of algae and cause some unexpected changes in community structure, suggesting a strong top-down effect on the algal community. Birds tend to consume the upper parts of the algal growth, but in so doing, they change the habitat for the invertebrate herbivores on the algae. Avian herbivory is different from invertebrate herbivory in its seasonal nature, which is often intense, during a shorter period of time. Because many invertebrates use the algae as habitat, the changes in algal community composition and density can lead to indirect effects on the invertebrates. One grazer of aquatic microorganisms is fish, such as ayu, *Plecoglossus altivelis* Temminck et Schegel, which graze differentially on algae in Japan (Abe et al. 2006). The ayu graze at different rates on diatoms and upright and prostrate cyanobacteria, which results in the pattern of dominance by the upright filamentous cyanobacteria. How the algae and diatoms attach to the substrate helps determine the extent to which they are grazed.

Many grazing studies have taken place in temperate region streams, which led Barbee (2005) to extend his studies to grazing by insects in tropical streams. In temperate regions the stream herbivores are dominated by insects and snails, while in tropical regions, the streams are dominated by herbivorous fish and crayfish. Do these different dominant herbivores have different effects? Barbee showed that aquatic insects in a coastal stream in Costa Rica decreased the biomass of resident algae and that there appears to be a continuum of which taxa contribute most to controlling benthic communities as opposed to the hypothesis that there is a shift in which macroorganisms dominate between temperate and tropical regions.

These studies show that grazing by larger and smaller predators can influence the microbial biomass and the composition of the communities. However, the picture is actually quite a bit more complex. Bottom-up (nutrient limitation) and top-down (predator or grazer limitation) forces are generally considered equally important, but is this always true? Darcy-Hall and Hall (Darcy-Hall 2006; Darcy-Hall and Hall 2008) asked whether grazer limitation on producers could be more important than nutrient limitation, with enough nutrients available, as predicted by their simple food chain model. Darcy-Hall (2006) examined this relationship across an environmental gradient of lakes with differing amounts of nutrients and algal species composition, factors lacking in many preceding

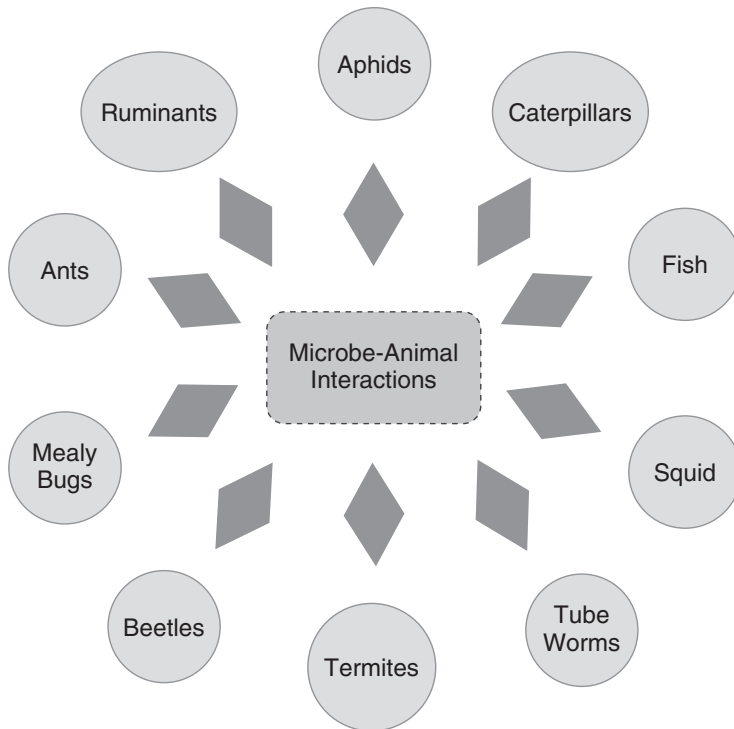
studies. She found that, contrary to the model's prediction, nutrient limitation exceeded the influence of grazer limitation across the environmental gradient of productivity in systems with vulnerable and resistant algal species, as opposed to historically ungrazed systems in which the producers were all vulnerable. Thus, shifts in producer composition or life-stage vulnerability, as a result of grazing can influence the top-down and bottom-up forces. In this situation, systems may show a shift from grazing limitation to nutrient limitation along a gradient of nutrient enrichment. This study demonstrates the importance of taking multiple factors into consideration when examining forces that shape microbial community structure. Much larger herbivores, such as cattle and sheep, have effects on soil microbial communities because of their grazing, their deposition of feces and urine, and the physical trampling that their movement causes. Grazing and animal excrement deposition cause changes in carbon and nitrogen cycling to the soil microbial community, which can result in community structure changes. Compaction changes many soil characteristics, which can also lead to changes in the microbial community (Kohler et al. 2005). As with much of microbial ecology, these studies of grazing on microbial communities highlight that there is still much to study to understand the impact of grazing on the microbial world.

## 8.9 SUMMARY

Symbioses are widespread in the animal tree of life (Figure 8.11), and evidence supports the hypothesis that they have arisen independently many times. Perhaps the most significant symbioses are the ones that led to the advent of the eukaryotic cell and the incorporation of Alphaproteobacteria and Cyanobacteria that led to the development of mitochondria and chloroplasts, respectively. Symbiotic relationships convey many advantages, such as the provision of needed nutrients to the host, and assist with nitrogen cycling. Symbionts can be primary (transmitted vertically and most often mutualistically) or secondary (transmitted vertically or horizontally, and either mutualistically, parasitically, or some combination). *Wolbachia pipientis* is one of the most ubiquitous and successful symbionts on Earth and has been shown to have both deleterious and beneficial aspects in its interactions with its hosts. Some of the most amazing endosymbionts occur in the guts of ruminants and termites, where one finds symbiotic fungi, archaea, bacteria, and protists and symbionts having their own endosymbionts. Their role in breaking down cellulose has had a profound effect on the evolution of these animals. Human gut symbionts are receiving increasing attention and may even play a role in obesity. Besides the endosymbiotic symbionts, there are examples of external mutualisms, such as the ants and beetles that tend fungal gardens. A rich habitat for symbioses is the deep-sea vent communities where animals harbor a diverse array of endosymbionts that play critical roles in host nutrition. Other animal-microbe interactions include grazing and predation of microbial communities by a variety of invertebrate and vertebrate predators that can shape the species makeup of the community. The interactions between animals and microbes have strong evolutionary effects on both and play critical roles in animal survival.

## 8.10 DELVING DEEPER: CRITICAL THINKING QUESTIONS

1. What are the evolutionary advantages of symbioses between animals and microorganisms?



**Figure 8.11.** Interactions between microorganisms and animals occur widely across the animal kingdom.

2. Why do so many endosymbionts occur in the Gammaproteobacteria?
3. What role is symbiosis believed to have played in the development of the eukaryotic cell?
4. As a symbiosis evolves, what changes must the symbiont and the host make to enable this new interaction to work over time?
5. Compare and contrast primary and secondary symbionts.
6. What is the evolutionary significance of gut symbioses? Why is this such a beneficial symbiosis?
7. What controls the diversity of symbionts at deep-sea vents?
8. The hoatzin represents a rare symbiosis among birds; what evolutionary factor(s) might have driven the development of this symbiosis?
9. What factors influence grazing and grazing resistance?

## BIBLIOGRAPHIC MATERIAL

### Further Reading

Moya A, Peretó J, Gil R, Latorre A (2008), Learning how to live together: Genomic insights into prokaryote—animal symbioses, *Nature Rev. Genetics* **9**:218–230.

## Cited References

- Abe S-I, Kiso K, Katano O, Yamamoto S, Nagumo T, Tanaka J (2006), Impacts of differential consumption by the grazing fish, *Plecoglossus altivelis*, on the benthic algal composition in the Chikuma River, Japan, *Phycol. Res.* **54**:94–98.
- Alizon S (2008), Decreased overall virulence in coinfecting hosts leads to the persistence of virulent parasites, *Am. Naturalist* **172**:E67–E79.
- Azambuja P, Garcia ES, Ratcliffe, NA (2005), Gut microbiota and parasite transmission by insect vectors, *Trends Parasitol.* **21**:568–572.
- Barbee NC (2005), Grazing insects reduce algal biomass in a neotropical stream, *Hydrobiologia* **532**:153–165.
- Dale C, Moran NA (2006), Molecular interactions between bacterial symbionts and their hosts, *Cell* **126**:453–465.
- Darcy-Hall TL (2006), Relative strengths of benthic algal nutrient and grazer limitation along a lake productivity gradient, *Oecologia* **148**:660–671.
- Darcy-Hall TL, Hall Sr (2008), Linking limitation to species composition: Importance of inter- and intra-specific variation in grazing resistance, *Oecologia* **155**:797–808.
- Dillon RJ, Dillon VM (2004), The gut bacteria of insects: nonpathogenic interactions, *Annu. Rev. Entomol.* **49**:71–92.
- Godoy-Vitorino f, Ley RE, Gao Z, Pei Z, Ortiz-Zuazaga H, Pericchi LR, Garcia-Amado MA, Michelangeli F, Blaser MJ, Gordon JI, Domínguez-Bello MG (2008), Bacterial community in the crop of the hoatzin, a Neotropical folivorous flying bird, *Appl. Environ. Microbiol.* **74**:5905–5912.
- Hallem EA, Rangarajan M, Ciche TA, Sternberg PW (2007), A tripartite model for nematode parasitism, *Curr. Biol.* **17**:898–904.
- Hori M, Noda T, Nakao S (2006), Effects of avian grazing on the algal community and small invertebrates in the rocky intertidal zone, *Ecol. Res.* **21**:768–775.
- Iturbe-Ormaetxe I, O'Neill SL (2007), *Wolbachia*—host interactions: Connecting phenotype to genotype, *Curr. Opin. Microbiol.* **10**:221–224.
- Kamra DN (2005), Rumen microbial ecosystem, *Curr. Sci.* **89**:124–135.
- Kohler F, Hamelin J, Gillet F, Gobat J-M, Buttler A (2005), Soil microbial community changes in wooded mountain pastures due to simulated effects of cattle grazing, *Plant Soil* **278**:327–340.
- Kono M, Koga R, Shimada M, Fukatsu T (2008), Infection dynamics of coexisting Beta- and Gammaproteobacteria in the nested endosymbiotic system of mealybugs, *Appl. Environ. Microbiol.* **74**:4175–4184.
- Ley RE, Bäckhed F, Turnbaugh P, Lozupone CA, Knight RD, Gordon JI (2005), Obesity alters gut microbial ecology, *Proc. Natl. Acad. Sci. (USA)* **102**:11070–11075.
- Ley RE, Hamady M, Lozupone C, Turnbaugh PJ, Ramey RR, Bircher JS, Schlegel ML, Tucker TA, Schrenzel MD, Knight R, Gordon JI (2008), Evolution of mammals and their gut microbes, *Science* **320**:1647–1651.
- Ley RE, Turnbaugh PJ, Klein S, Gordon JI (2006), Human gut microbes associated with obesity, *Nature* **444**:1022–1023.
- Li M, Wang B, Zhang M, Rantalainen M, Wang S, Zhou H, Zhang Y, Shen J, Pang X, Zhang M, Wei H, Chen Y, Lu H, Zuo J, Su M, Qiu Y, Jia W, Xiao C, Smith LM, Yang S, Holmes E, Tang H, Zhao G, Nicholson HK, Li L, Zhao L, (2008), Symbiotic gut microbes modulate human metabolic phenotypes, *Proc. Natl. Acad. Sci. USA* **105**:2117–2122.
- Lombardo MP (2008), Access to mutualistic endosymbiotic microbes: An underappreciated benefit of group living, *Behav. Ecol. Sociobiol.* **62**:479–497.
- Margulis L (1993), *Symbiosis in Cell Evolution*, New York: Freeman.



- Margulis L (1998), *Symbiotic Planet: A New Look at Evolution*, New York: Basic Books.
- Margulis L, Chapman MJ (1998), Endosymbioses: Cyclical and permanent in evolution, *Trends Microbiol.* **6**:342–345.
- Margulis L, Dolan MF, Guerrero R (2000), The chimeric eukaryote: Origin of the nucleus from the karyomastont in amitochondriate protists, *Proc. Natl. Acad. Sci. (USA)* **97**:6954–6959.
- Matz C, Kjelleberg S (2005), Off the hook—how bacteria survive protozoan grazing, *Trends Microbiol.* **13**:302–307.
- McGonigle TP (2007), Effects of animals grazing on fungi, in Kubicek CP, Druzhinina IS, eds., *Environmental and Microbial Relationships*, 2nd ed., Berlin: Springer-Verlag; see also *Mycota* **4**:201–212.
- Moya A, Peretó J, Gil R, Latorre A (2008), Learning how to live together: Genomic insights into prokaryote–animal symbioses, *Nature Rev. Genetics* **9**:218–230.
- Nakagawa S, Takai K (2008), Deep-sea vent chemoautotrophs: Diversity, biochemistry and ecological significance, *FEMS Microbiol. Ecol.* **65**:1–14.
- Ohkuma M (2008), Symbioses of flagellates and prokaryotes in the gut of lower termites, *Trends Microbiol.* **16**:345–352.
- Paine TD, Raffa KF, Harrington TC (1997), Interactions between scolytid bark beetles, their associated fungi and live host conifers, *Annu. Rev. Entomol.* **42**:179–206.
- Rouse GW, Goffredi SK, Vrijenhoek RC (2004), *Osedax*: Bone-eating marine worms with dwarf males, *Science* **305**:668–671.
- Siozios S, Sapountz P, Ioannidis P, Bourtzis K (2008), *Wolbachia* symbiosis and insect immune response, *Insect Sci.* **15**:89–100.
- Stewart FJ, Cavanaugh CM (2006), Bacterial endosymbioses in *Solemya* (Mollusca: Bivalvia)—model systems for studies of symbiont–host adaptation, *Antonie van Leeuwenhoek* **90**:343–360.
- Suttle CA (2006), Viruses in the sea, *Nature* **437**:356–361.
- Thao ML, Gullan PJ, Baumann P (2008), Secondary ( $\gamma$ -*Proteobacteria*) endosymbionts infect the primary ( $\beta$ -*Proteobacteria*) endosymbionts of mealybugs multiple times and coevolve with their hosts, *Appl. Environ. Microbiol.* **68**:3190–3197.
- Turner PE (2003), Parasitism between co-infecting bacteriophages, *Adv. Ecol. Res.* **37**:309–332.
- Van Dover CL, German CR, Speer, KG, Parson LM, Vrijenhoek RC (2002), Evolution and biogeography of deep-sea vent and seep invertebrates, *Science* **295**:1253–1257.
- Walker A (2007), Say hello to our little friends, *Nature Rev. Microbiol.* **5**:572–573.
- Wallace RJ (2008), Gut microbiology—broad genetic diversity, yet specific metabolic niches, *Animal* **2**:661–668.
- Wommack EC, Colwell RR (2000), Virioplankton: Viruses in aquatic ecosystems, *Microbiol. Molec. Biol. Rev.* **64**:69–114.
- Zimmer C (2003), *Parasite Rex: Inside the Bizarre World of Nature's Most Dangerous Creatures*, London: Arrow Books.

### Internet Sources

<http://www.wolbachia.sols.uq.edu.au/>.

<http://iss-symbiosis.org/> *International Symbiosis Society*.

# LIVING TOGETHER: MICROBIAL COMMUNITIES

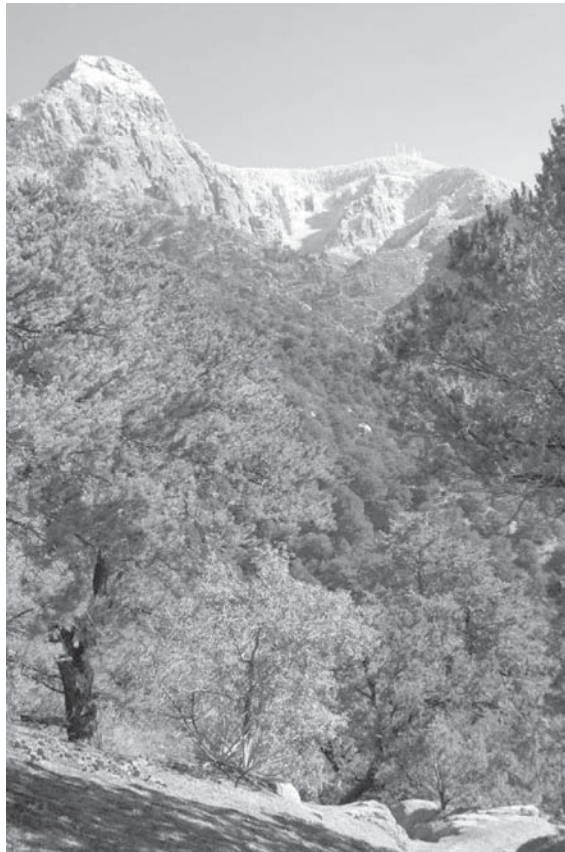
## 9.1 CENTRAL THEMES

- New molecular tools such as metagenomics are shedding light on the nature of community members and the functions they perform in the environment.
- Microbiologists have moved from studying free-living, planktonic microorganisms to the study of biofilms.
- Microbial biogeography supports the idea that “everything is everywhere” and that the “environment selects.” But is this always true?
- Studies of the newborn gut, whale falls in the ocean, and the recolonization of environments such as intertidal sediments after disturbance are shedding new light on the colonization, formation, and succession of communities.
- Disturbance can affect recolonization and species diversity in communities.
- Within food webs, microorganisms dominate the flux of energy in marine and terrestrial systems, and the true complexity of the microbial/metazoan interactions is just beginning to be recognized.
- Microorganisms are the engineers of our planet, cycling key nutrients such as C, N, and P.
- We have greatly expanded our knowledge of habitats in which we find microbial communities, including the human mouth, hot springs (terrestrial and deep-sea), and

wine. Many of these habitats are revealing extensive novel diversity, thereby filling in the tree of life.

## 9.2 INTRODUCTION

In the macroscopic world we can readily examine communities; for example, in the southwestern United States, we can walk through a pinyon–juniper community (Figure 9.1), where pinyon pine and juniper trees appear to dominate the landscape. Less obvious to us humans are the microbial communities that inhabit these landscapes. In this habitat the soil contains an amazing microbial community; the roots of the trees are inhabited by a rhizosphere microbial community, while the needles of the evergreens or leaves of the oak trees have entirely different microbial communities. Rhizosphere microbial communities are not readily apparent to humans; much more obvious to us are the hot springs, such as in Yellowstone National Park in Wyoming, where microbial communities dominate the environment (Figure 9.2) and you can see visible microbial growth.



**Figure 9.1.** Pinyon–juniper forest at the base of the Sandia Mountains, New Mexico, USA (photo courtesy of K. Ingham, copyright 2004).



**Figure 9.2.** Hot springs in Yellowstone National Park, Wyoming, USA, harbor a wealth of bacterial species. See insert for color representation.

Community ecology is the study of the interactions among species that live together in a defined physical area and the biogeography, abundance, and distribution of the coexisting populations. Two important aspects of communities include the community boundary and the structure of the community. Some community boundaries are easier to recognize than others. You may think that the boundaries of the hot springs are more obvious than those of the rhizosphere communities, but in actuality hot springs extend for unknown distances underground. The structure of a microbial community is defined as the species makeup, the number of species (richness), and the relative abundance of different species within the community. Ecologists have spent decades working out the community structures of various macroscopic communities such as our pinyon–juniper community, but who dominates, who is rare, and who is abundant, which species interact, and a host of other community ecology questions are just being worked out for microbial communities. New technologies and insights have made this possible. In this chapter we'll explore these topics.

### 9.2.1 Dominant Issues and Questions in Microbial Community Ecology

The last decade of microbial community ecology has been dominated by studies of species diversity and an ever-increasing number of habitats. The discovery that we can grow less than 1% of the species of bacteria that are present in the environment using standard microbiological culture techniques has led to studies dominated by culture-independent

techniques that employ molecular phylogenetic analyses (see Section 5.6). For example, our previous concept that a few species of bacteria live in the human mouth, based on early culturing efforts, has been replaced by the knowledge that 500 species of bacteria exist there, as revealed by genetic sequence data. To study this extensive novel species diversity, new tools such as metagenomics are being developed that disclose the nature of the community members and their functional roles. What controls this diversity in terrestrial and aquatic environments is still under investigation, but broad studies indicate that abiotic factors such as pH exert strong controls on diversity. The rainforest, once thought to be the most diverse habitat on Earth, has been shown to be less diverse in terms of microbial species than deserts, with their more alkaline soils. A major issue in the study of diversity is whether the environment controls which species inhabit which areas or whether true biogeographic patterns exist.

Increasingly we are examining the role of bacteria in moderating the influences of ecosystem disturbance. From these studies and more basic science, we are investigating the fundamental roles that bacteria and other microorganisms play in the cycling of carbon, nitrogen, phosphorus, and other nutrients in the ecosystem. These, and other issues related to the central themes of the chapter, will be explored in the following pages.

### 9.3 METAGENOMICS: A NEW TOOL FOR ANSWERING COMMUNITY ECOLOGY QUESTIONS

We have progressed greatly in more recent decades in analyzing what microorganisms are present in the environment using culture-independent (see Section 5.6) methods, but we have lacked an overall understanding of the microorganisms and their roles in a given habitat or community. A new method, metagenomics (discussed in Section 5.9), which has emerged since the 1990s, allows us to examine communities in more detail. *Metagenomics* is the analysis of an assemblage or community of microorganisms, such as microbial populations in a lake, using culture-independent methods to analyze the entire genome of all population members to shed light on the nature and function of the microorganisms present (Riesenfeld et al. 2004).

The first large-scale metagenomic study was performed by the J. Craig Venter Institute on the Sargasso Sea microbial community. Because this was thought to be a relatively simple community, due to nutrient limitation, the investigators thought that they would be able to assemble many of the genomes present. However, the Sargasso Sea community proved to be more complex than thought. Subsequent efforts have explored the acid mine drainage (AMD) community of Iron Mountain in California (USA), soil and marine water communities, and insect gut communities, all of which shed light on the identity and functional nature of the community [reviewed in Sleator et al. (2008)]. For example, the AMD study revealed that the major organisms present contained a large number of genes for dealing with substances that would be toxic to the cells and allowed the researchers to construct almost complete genomes for two of the major players, *Ferroplasma* type II and *Leptospirillum* group II. Another example of the results of community metagenomic studies comes from the Mediterranean Sea. Analysis of a deep-sea community revealed that the bacteria present were heterotrophs that contained genes for organic matter catabolism, transport, and degradation [reviewed in Sleator et al. (2008)]. These examples demonstrate the power of metagenomic analyses and the promise of future discoveries about microbial communities.

## 9.4 BIOMATS AND BIOFILMS

We have every reason to be embarrassed because we (as microbiologists) have spent 150 years studying the minor bacterial phenotype (planktonic cells), while assiduously ignoring the major phenotype (the biofilm) that predominates in natural and pathogenic ecosystems.

—Costerton (2004)

In the 1930s and 1940s, researchers such as Claude ZoBell (1943) documented the importance of solid surfaces for bacterial growth. Bacterial communities on these surfaces were viewed as simple communities of attached bacteria and not the dynamic, complex architectures that we more recently elucidated in community studies. Stop for a moment and see how many examples of biofilms you can think of in your environment.

This might make you think of the scum on your teeth in the morning or the slimy feel of the cats' water bowls if you don't change the water. These are only a few examples of biofilms, which have been found to be ubiquitous in nature. In studying biofilms, we have come to realize that pure cultures of microorganisms in the lab are a poor substitute for the study of communities of organisms in their native environment. Organisms often grow in synergy in matrices and behave very differently in the "wild" than in pure culture as planktonic organisms. Imagine the excitement of J. William Costerton, a pioneer in biofilm studies, when he viewed *E. coli* attached to intestinal walls by a polysaccharide matrix for the first time. These early studies have been greatly expanded and now incorporate the study of biofilms in pathogenic processes. Infections that are resistant to antibiotics may be the result of bacteria living in a biofilm, providing an important impetus for studying biofilm communities.

To set the stage for what you're about to read, view some of the biofilm movies created by the laboratory of Paul Stoodley at <http://www.erc.montana.edu/>.

Definitions of biofilms usually incorporate three main ideas:

- Structured communities of one or more species of microorganisms
- Production by community members of a matrix that is characterized as a hydrogel
- Adherence to a biological or abiological substrate or interface

Biofilms are communities of microorganisms embedded in a matrix, usually adhering to a surface. Organisms gain much from living in the structured environment of a biofilm community. Living in houses protects us from the weather (desiccation, freezing, UV damage, etc.); living in biofilms protects microorganisms from similar threats, as well as stressors more specific to microorganisms, such as pH extremes. Biofilms can shield microorganisms from a variety of harmful substances, including toxic metals, salts, antibiotics, and predators. *Yersinia pestis*, the bacterium that causes plague, is transmitted by bites of fleas whose intestinal systems are blocked by the bacterial biofilms (Brandt et al. 2005); the biofilms aid in transmission, but also protect the bacteria from predation. Microbial biofilms also have important implications for humans. Early in the 1980s, researchers discovered that bacteria such as staphylococci inhabited medical devices and were protected from antibiotics by their biofilms. This discovery provided a powerful motivation for humans to study biofilms, and researchers have pieced together key information about how biofilms form that will allow us to better combat microbial diseases that are resistant to treatment because of their biofilm nature.



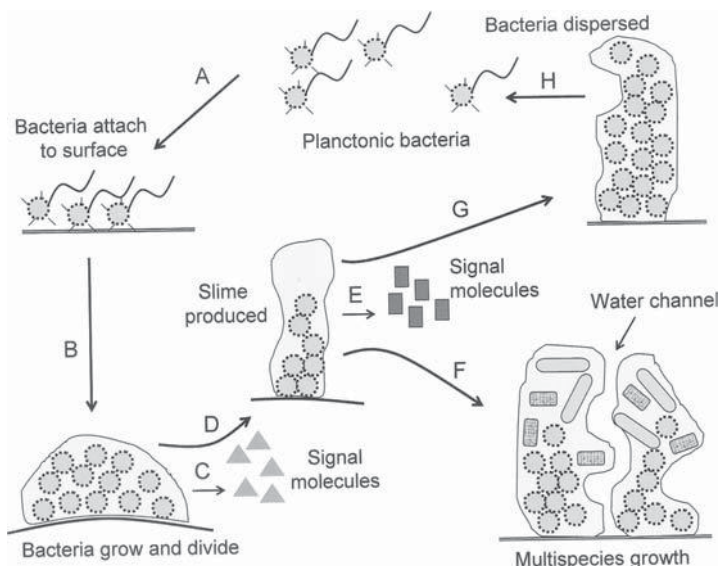
Biofilm morphology has been characterized as colonies or pellicles (free-floating). Four stages of growth and development have been characterized, as shown in Figure 9.3:

- Planktonic cells adhere, reversibly, to a surface or interface.
- Cells multiply and form a nonreversible attachment.
- The biofilm community grows, adding to the three-dimensionality of the community.
- As the biofilm reaches maturity, parts detach in a dispersal stage that initiates new biofilms.

During the attachment and adherence stages, species attract potential partners by signaling. The partner species come together and clump in a process called *coaggregation* (Rickard et al. 2003). This contrasts with *coadhesion*, in which free-floating species attach to a species that is already attached to a surface as part of a biofilm.

The degree to which biofilm formation and the type of structures that are formed are controlled by genetics or the environment is an area of active research. Genes are involved in cell–cell signaling, adhesion, and the formation of pili, flagella, and extrapolymeric substances (EPSs). However, when researchers knock out particular genes through mutagenesis studies, they find that biofilm formation is not prevented, indicating redundancy in the genes.

In different environmental conditions diverse kinds of biofilms form. Key environmental factors that affect the kind of biofilm formed include fluid shear and the amount and kind of nutrients available. Working together, engineers and biologists have shed light on the viscoelastic and hydrogel characteristics of biofilms! In the case of biofilms characterized as hydrogels, the biofilm polymer is hydrated with water, forming a viscous jelly-like matrix. Fluid shear can deform the viscous matrix, and the biofilm will break under the shear forces if its tensile strength is exceeded.



**Figure 9.3.** Biofilms undergo several stages of development in an iterative process [modified from Harrison et al. (2005)].

These discoveries about the nature of biofilms and how they form are key to our protecting important and helpful biofilms in nature and to understanding how to combat diseases caused by microorganisms that live in the protective environment of biofilms. In some diseases, such as dental plaque, we also need to understand how these biofilms change over time.

#### 9.4.1 Changes in Community Structure during Biofilm Succession

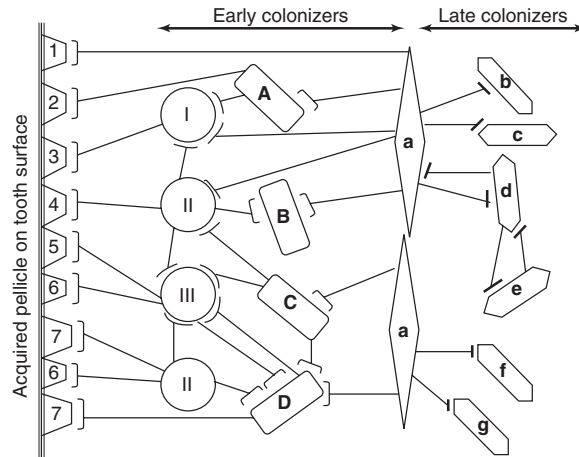
A model system for studying community changes during biofilm creation and development is the formation of dental plaque. Of the 500 species known to occur in the human mouth, many are culturable, and their interactions with each other and the various molecules in the mouth have been studied extensively. Because many of the bacteria living in the mouth contribute to disease, the incentive is there to study them. Studies by Kolenbrander et al. (2002) illustrate that there are early and later colonizers. Amazingly, just hours after teeth cleaning, a new biofilm will start to form, proceeding in an orderly progression of events:

1. Early colonizers, usually members of the genus *Streptococcus*, will attach, using compounds called *adhesins*, to various receptors in the new biofilm on a tooth.
2. Other early colonizers (pioneers) will bind to these pioneer species, forming a variety of coaggregations.
3. Early colonizers coaggregate with some other early colonizers, but not with late colonizers, who rarely coaggregate with other species.
4. One particular type of bacteria, fusobacteria, coaggregate with both early and late colonizers forming a link within the biofilm.

This is illustrated in Figure 9.4 and in greater detail in the work of Kolenbrander et al. (2002). Many of the oral bacteria can also use some receptor molecules as nutrient sources. Oral bacteria also regulate specific genes in response to interactions with other bacteria or environmental molecules. Biofilm formation following teeth cleaning is a very ordered and sequential process with an abundance of different species interactions. Because dental plaque can lead to disease, the microbial colonization and progression within biofilms is an important process to study. Initiation of the formation of biofilms may begin with cell–cell communication, in a process called *quorum sensing*.

### 9.5 FORMATION OF ORGANIZED COMMUNITIES: QUORUM SENSING

Many pathogenic and symbiotic relationships between bacteria and eukaryotes depend on communication among bacterial cells. Quorum sensing is one avenue that cells utilize and is an important part of biofilm formation and extracellular polymeric substance production discussed earlier. Quorum sensing is also important in toxin, antibiotic, and virulence factor production and competence, conjugation, sporulation, and motility such as that seen in *Myxococcus xanthus* when they produce fruiting bodies. Evidence suggests that communication can be intraspecies or between species and is widespread within the Bacteria. This communication occurs between bacteria of the same and different species and among Gram-positive and Gram-negative bacteria. Miller and Bassler (2001)



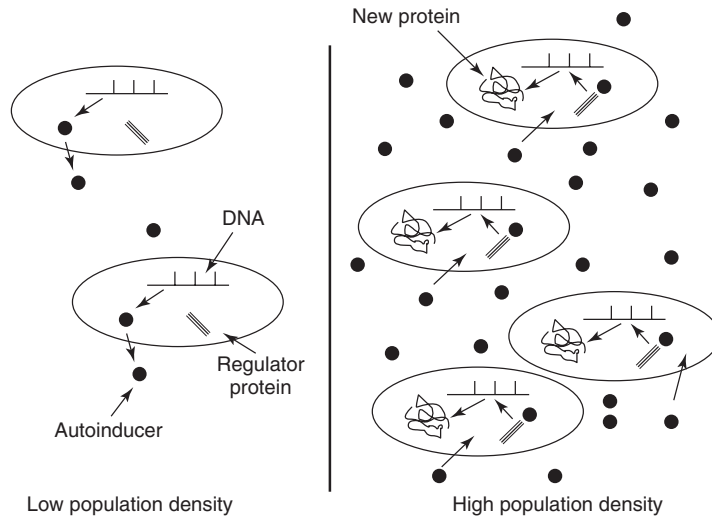
**Figure 9.4.** Formation of dental plaque biofilm is a specific process. (1) oral agglutinin, (2) bacterial cell fragment, (3) sialylated mucins, (4)  $\alpha$ -amylase, (5) salivary agglutinin, (6) bacterial cell fragment, and (7) proline-rich protein. (I) *Streptococcus oralis*, *Streptococcus mitis*, *Streptococcus sanguis*; (II) *Streptococcus gordonii*; and (III) *Streptococcus oralis*. (A) *Haemophilus parainfluenzae*, (B) *Propionibacterium acnes*, (C) *Veillonella atypica*, and (D) *Actinomyces naeslundii*. (a) *Fusobacterium nucleatum* (b) *Prevotella intermedia* (c) *Actinobacillus actinomycetemcomitans* (d) *Treponema denticola*. (e) *Porphyromonas gingivalis* (f) *Eubacterium* sp. (g) *Selenomonas flueggei* [modified from Kolenbrander et al. (2002)].

speculate that quorum sensing is in a sense the beginnings of multicellularity. We have also discovered that some eukaryotes can interfere with quorum sensing by producing quorum-sensing-interfering (QSI) substances (González and Keshavan 2006). These QSI hold the promise of controlling unwanted microbial actions. Thus, controlling pathogens, and hence disease, may rest on our ability to understand quorum sensing.

You can readily understand how you communicate with your fellow humans, but think about communicating with your pals if you're a bacterium. Bacteria release chemical regulator substances called *autoinducers* into the environment. At low population densities the autoinducer signal is diluted and does not provoke a change. At higher population densities, autoinducers accumulate to the point that they cross a threshold that leads to a change in the expression of target genes as part of a quorum-sensing cascade (Figure 9.5). The central feature of quorum sensing is the ability to coordinate gene expression, which then influences community behavior.

The discovery of quorum sensing dates back to 1970 and was one of those “That’s interesting . . .” moments for Kenneth Nealson and John Hastings of Harvard University. They noticed that the luminescent bacterium *Photobacterium fischeri* did not fluoresce unless there were sufficient numbers of bacteria. They hypothesized that these bacteria produced substances that they called *autoinducers* that trigger a change in gene expression leading to luminescence (see additional information in Section 8.5.5).

The autoinducer produced by *P. fischeri*, *N*-acylhomoserine lactone (AHL), is utilized by several other genera of Gram-negative bacteria in quorum sensing networks. AHLs are the major autoinducers and are an important weapon in the war between the bacteria and their hosts. If they were to trigger virulence factors before their cell densities ensured a successful campaign against the host, the immune response of the host would be



**Figure 9.5.** At low population densities autoinducer levels are too low to trigger quorum sensing; as densities increase, a threshold level of autoinducers is crossed and the quorum-sensing cascade is initiated [modified from González and Keshavan (2006)].

activated and the bacteria might be less successful. Gram-positive bacteria use processed oligopeptides in communication. Intensively studied systems include the control of virulence in *Staphylococcus aureus*, competence in *Streptococcus pneumoniae*, and sporulation and competence in *Bacillus subtilis*. Another class of autoinducers, AI-2, facilitates interspecies communication and is considered a global signaling compound (González and Keshavan 2006) that is found in both Gram-positive and Gram-negative bacteria.

These important discoveries of how quorum sensing is initiated and controlled help us understand how biofilm communities are created and may help us understand how to control unwanted microbial community formation. Additional information on quorum sensing is presented in Section 3.8.1.

Now we turn to some key characteristics of communities, such as how microorganisms disperse, how they colonize and recolonize habitats to form communities, how the communities change over time (succession), and how species diversity is controlled within communities.

## 9.6 COLONIZATION AND RECOLONIZATION BY MICROORGANISMS

The ultimate colonization event was the colonization of Earth and subsequently the land by Bacteria and Archaea. Today many studies examine how microorganisms colonize entirely new habitats such as freshly cooled lava, newborn guts, and emerging leaves. Of critical importance for humans is how microorganisms colonize wounds, medical devices and implants, transplants, contact lenses, and other materials. These microbial colonization events often lead to pathogenic processes, and their study can lead to new insights into how to control microbial pathogenesis. Of less personal concern is the microbial colonization of water pipes, stainless steel, and other inanimate parts of our

lives, which can lead to fouling and destruction of substances such as steel and concrete. The effects of corroded concrete in a bridge can be disastrous. On the other hand, some microbial colonization events are very helpful to humans, such as the colonization of plant roots by nitrogen-fixing bacteria and mycorrhizal fungi that facilitate plant growth. A list of article titles about microbial colonization in more recent years shows the breadth of habitats examined:

- “Microbial colonization of tourniquets.”
- “Bacterial colonization, probiotics, and clinical disease.”
- “Significance of microbial colonisation in materials for orthopedic technology.”
- “Bacterial colonisation of the infant gut, the influence of diet and its role in health.”
- “Hypolithic colonization of opaque rocks in the Arctic.”
- “Microbial colonization of rock surfaces; random or mineral specific selection?”
- “Microbial colonization of the hands of residents.”

The list of topics is endless and fascinating in the range of habitats that have been examined. What events lead to colonization or recolonization?

Catastrophic natural events (disturbance) such as fire and volcanic eruptions can result in the scouring of a habitat of all life. Microorganisms rapidly recolonize these barren surfaces, coming from surrounding areas, blown in on air currents, carried in on animals and plants returning to disturbed areas (immigration and recruitment), and recovering from remnant populations (regrowth). The human body is often the focus of colonization events by microorganisms. The gastrointestinal (GI) tract has been the focus of some studies to reveal common themes in colonization events leading to disease. In the following case studies we’ll examine some of the important aspects of colonization, including factors that lead to successful colonization by our beneficial inhabitants of the human gut and unwelcome colonizers such as pathogenic GI bacteria. We’ll also examine the sources of colonizers in habitats such as intertidal flats and whale carcasses on the ocean floor.

### 9.6.1 Case Study: Colonization of the Sterile Newborn Gut

An ideal environment in which to study microbial colonization is that of the human newborn gut, which is sterile at birth, but colonized within hours, eventually developing a community of 400 aerobic and anaerobic species. Colonization of the gut is influenced by maternal and environmental factors. The mother’s diet, stress level, bacterial flora, and mode of delivery are strong controllers of the nature of the newborn’s initial microbial flora. Babies delivered by Caesarean section (C section) show a pattern of colonization by bacteria from the hospital environment.

Breastfeeding produces an infant gut flora different from that seen in formula-fed babies. Mothers who breastfeed transmit lactobacilli and bifidobacteria in much greater numbers than those in Enterobacteriaceae, while babies fed formula develop a community dominated by Enterobacteriaceae that develops more quickly than does the community in breastfed babies.

The microbial composition of the infant gut shifts to a pattern more similar to that of adults around the time of weaning. Fewer *E. coli* and *Clostridium* are present, and more *Bacteroides* and Gram-positive anaerobic cocci appear. Study of the colonization of the newborn gut has provided key information about the microbial colonization of new habitats and can help us understand how successful colonization is achieved.

### 9.6.2 Case Study: Undesirable Colonization—Factors in Disease

Some microbial colonization is not welcome and is actively defended against. The gastrointestinal tract is a hostile place for invading pathogenic microorganisms, which encounter stomach acid, bile salts, and the barrier presented by the intestinal epithelial cells. Invaders have developed several strategies for evading defense mechanisms of the host in order to successfully colonize the GI tract. Indeed, transport through a host can lead to key gene expression changes in the pathogens, which allow for successful colonization of the next host. West et al. (2003) discuss the ability of bacteria to effectively use adhesins to bind to intestinal epithelial cells and invasins that mediate cell entry by microorganisms. In common usage, the term *adhesins* refers to microbial surface antigens, often in the form of filamentous pili or fimbriae, that bind bacteria to cells. Understanding such colonization strategies by invading pathogenic bacteria can lead to effective strategies to combat gastrointestinal microbial disease.

### 9.6.3 Case Study: Recolonization and Early Succession in Intertidal Sediments

Recolonization events follow disturbance (see Section 9.8.3) and can result from immigration, recruitment, or regrowth. In the following example, we'll look at whether microbial recolonization in intertidal sediments resulted from the recruitment from microorganisms in the overlying water column or air, from the regrowth of microorganisms that survived the passage through predator guts (egesta), and/or immigration from surrounding sediments. Plante and Wilde (2004) demonstrated that different organisms that feed on intertidal sediment communities ("deposit feeders") have differing degrees of disturbance on bacterial communities studied in these sediments. One deposit feeder had very little effect on the bacterial community structure, while another had major effects on the metabolic capabilities of the bacterial community through biomass removal. Plante and Wilde's (2004) studies of recolonization of egesta from the deposit feeders provided data that pointed to immigration from adjacent sediments as the source of recolonizers, who appear to be able to detach from sediments and rapidly move to new sites. This study represents one habitat. Would these results change at larger scales?

## 9.7 DISPERSAL, SUCCESSION, AND STABILITY

Compared to plant and animal communities, microbial communities have a much greater diversity on several levels. They can be a mixture of bacterial and archaeal species and eukaryotes; they can be autotrophs or heterotrophs or both at different times in their lifecycle; or they may or may not need oxygen. These factors contribute complexity to modeling what structures microbial communities and their succession over time. Thus, we cannot simply apply plant or animal successional models to microorganisms. Some pioneering researchers are studying changes in species richness and resource availability over time and have used these data to propose models for microbial succession. We'll first examine a case study of succession in whale falls on the ocean floor in which facilitation, and not competition, is thought to play a dominant role in succession. Jackson (2003), on the other hand, takes the view that competition is a major structuring force in succession, and we will examine his competition model, one of the few models of competition to be proposed for microbial ecology.



### 9.7.1 Case Study: Dispersal and Succession in the Oceans—Whale Falls as Dispersal Agents between Vents

At erratic spatiotemporal intervals whales die and fall to the ocean floor, forming the basis for fascinating experiments in colonization, dispersal, and succession of bacterial and invertebrate communities. The fat-rich bone marrow of whale falls is a superb bonanza for microorganisms. Bacterial decomposition of the whale bone lipids releases sulfides that feed other organisms. Other bacteria have taken up residence in small worms called *Osedax*, assisting the worms in breaking down the marrow fat (see additional information in Section 8.5.2). This endosymbiosis is particularly unusual because of the heterotrophic degradation role that the bacteria play, in stark contrast to the chemolithoautotrophic bacterial endosymbionts found in other deep-sea organisms. Ecologically, whale falls are analogous to islands, and researchers have hypothesized that the whale falls act as dispersal agents between hydrothermal vents.

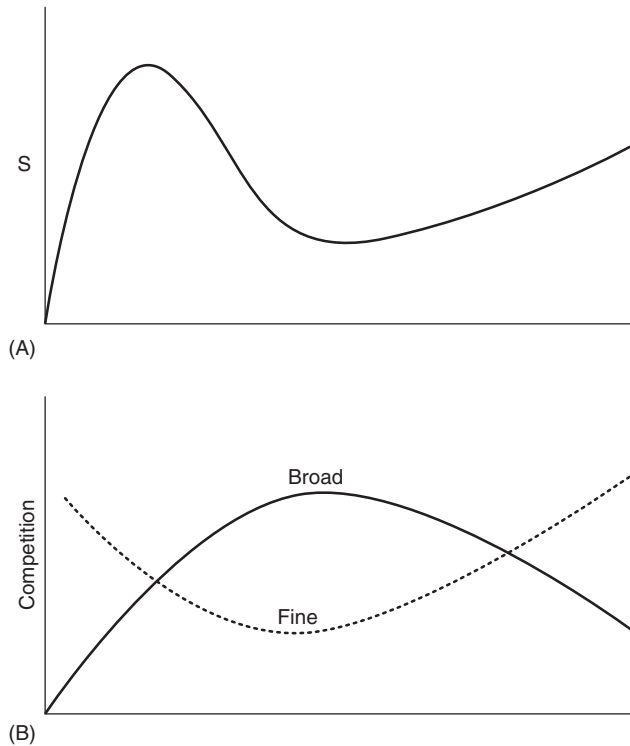
Smith and Baco (2003) have studied several of these whale falls, both natural and artificially placed, to come up with a model of succession and dispersal. They have proposed four stages of succession:

1. *Mobile scavenger*—vertebrates and invertebrates colonize and remove the whale's soft tissue.
2. *Enrichment opportunist stage*—polychaetes and crustaceans colonize surrounding sediments enriched from soft-tissue decomposition (oh, those sloppy eaters) and exposed bones.
3. *Sulfophilic stage*—a species-rich collection of organisms utilize sulfides being released during the breakdown of bone lipids by organisms that reduce seawater sulfate to sulfide during lipid breakdown.
4. *Reef*—suspension feeders use mineral components left after organic constituents are exhausted.

Drawing from the general ecological literature, they propose that the changes in species composition during succession stages that they observe are governed by facilitation, but that competition has little to do with the changes in species composition and trophic structure. Furthermore, whale falls may act as “dispersal stepping stones” between cold seeps and hydrothermal vents in the deep regions of the ocean. This case study illustrates some of the complexities of microbial community succession.

### 9.7.2 Competition as a Structuring Force in Succession

One model, proposed by Colin Jackson (2003) (Figure 9.6), suggests that broad- and fine-scale competition are major structuring forces in succession and community development. As species colonize new habitats, species richness ( $S$ ) increases over time in a biofilm. Along with this increase, resource diversity, or niche space, increases, as evidenced in studies by Jackson and others. The microorganisms colonizing the new habitat change their environment over time, creating new niche space to be colonized by other, more specialized species. These microorganisms also produce waste products that may support additional microbial species. Niche space increases over time as biofilms go from a more two-dimensional structure to a three-dimensional one.



**Figure 9.6.** Many species initially colonize a new habitat (A), but as competition for broad-scale resources increases (B), the number of species  $S$  decreases. Initially broad scale competition structures the community; as niche space increases, fine-scale competition succeeds broad-scale competition in importance (B). As fine-scale competition increasingly structures the niche space, the number of species  $S$  again increases (A). [Modified from Jackson (2003).]

Competition (broad scale) initially structures the community until niche space increases more (Jackson 2003; Figure 9.6), and you get the development of more specialized populations that require certain resources (e.g., sulfate for sulfate-reducing bacteria). The latter is fine-scale competition and becomes more important as niche space and diversity develop. The number of new populations is high initially, then falls off, and as the biofilm ages, increases again. Over time, as the biofilm matures, the community moves from being structured by resource diversity and competition to being structured by predation by viruses, protists, and other predators.

As we study these changes in additional environments, this model will continue to be tested and refined. How do you think this model would change in a habitat that receives new resources very slowly, such as a cave or in other regions of the subsurface? Do you believe that competition is an important force in structuring succession and community development over time?

### 9.7.3 Stability in Microcosm Studies

Stable communities are ones that return to their prior species composition, diversity, and abundance and that retain their genetic traits following a disturbance. Factors such

as environmental disturbance or the invasion of exotic species perturb the community structure and species diversity (richness and abundance). Whether a community returns to its former diversity and structure is a measure of community stability.

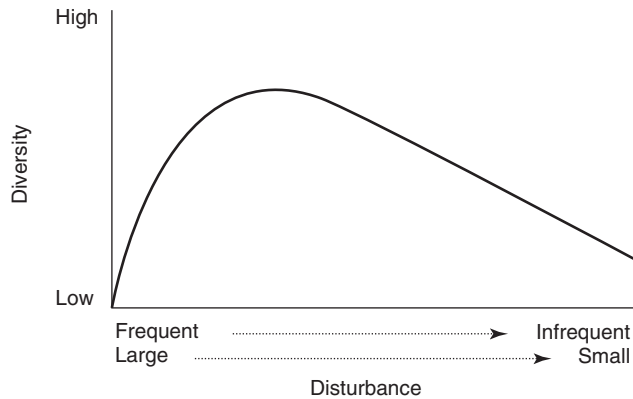
Violent storms and fire are common agents of short-term disturbance events (see Section 9.8.3 for additional discussions of disturbance). The ability of a system to return to an equilibrium state following such events is a measure of the system's stability. The concept of resilience is intimately linked to stability. Species diversity, and later species function, are recognized as important factors in resilience. *Resilience*, which originates from the Latin *resilire*, to rebound, denotes the ability of an ecosystem to return to its former state following a disturbance. A greater number of species (higher species richness) enhances ecosystem stability. Resilience and stability are discussed in further detail in Botton et al. (2006).

Kurihara (2004) has used microcosms to examine how selective forces such as predation and competition can affect original community members and the mutants that arise during disturbance. By first examining subsets of the ecological communities in these microcosms, Kurihara was able to show that mutants that arose could actually come to dominate or affect the simplified community. However, in the larger, more diverse communities, mutants rarely gained preeminence. This study supports the hypothesis that more diverse communities are more stable and sends a warning about reaching conclusions on the basis of an oversimplified community.

## 9.8 SPECIES DIVERSITY

When we talk about species diversity, we are actually talking about multiple concepts, including the number of species (richness) and their relative abundance (evenness) in a particular environment or community. Even such a simple definition is complicated in describing microbial species diversity because what defines a microbial species is controversial. Ernst Mayr's biological species concept defines a species as a group of interbreeding populations and is applied to eukaryotic organisms. In bacterial and archaeal microbial species, a species is commonly defined in terms of the degree of genetic relatedness based on DNA–DNA hybridization. Organisms whose purified genomic DNA hybridizes at >70% are deemed to be the same species. Two organisms are characterized as the same species if they share 97% (some researchers suggest 99% as the cutoff) 16S rRNA sequence identity. To avoid the ambiguity of what is a species, many microbial studies use the concept of operational taxonomic units (OTUs), phylotypes, or ecotypes. A more extensive discussion of the species concept can be found in Section 1.7.

Why is it important to study diversity? In the 1970s Carl Woese discovered that the previously named kingdom Monera was actually two fundamentally different domains of life: the *Bacteria* and the *Archaea*, the latter a previously unknown as a different, kingdom of life. In 1987 there were 11 phyla of the Bacteria (Woese 1987), and in 2003, Rappé and Giovannoni (2003) described the bacterial domain as having 52 phyla. There are informal reports that this number has doubled. The startling part of this rapid expansion is that only 26 of these phyla had cultured representatives at the time. The rest are known only from their genetic sequences derived from the environment and hence are known as “candidate phyla”. Thus, a critical need is to discover the true diversity of what Steve Giovannoni calls the “uncultured microbial majority.” The phylogenetic tree of these 52 phyla reveals that the Bacteria apparently diversified in a relatively



**Figure 9.7.** In the intermediate disturbance hypothesis, the level of disturbance affects the level of diversity, with the highest diversity occurring at moderate levels of disturbance as seen in the midportion of this graph [modified from Molles (2008)].

short period of time (Rappé and Giovannoni 2003). An important companion question concerns the roles that these microorganisms play in our world, especially in cycling critical elements biogeochemically. Little is known about the roles of the 26 candidate phyla. Phylogenetic analyses of the diversity of a given habitat can reveal the results of periodic selection (also called “selective sweep”). Neutral substitutions give rise to gene clusters in the environment; if a variant arises that has higher fitness than its conspecifics does, it will be favored and will take over the population. Thus, evolutionary events can be revealed in phylogenetic trees. Getting a handle on this vast diversity can be accomplished through the use of diversity indices.

### 9.8.1 Diversity Indices

When looking at the “diversity” of a community, you want to know how many species are present and their relative abundance—are there many rare species or a few dominant species? It is difficult to accurately assess these attributes in microbial communities that may have thousands of species present (e.g., in soil). New and cheaper sequencing methods are making this more possible. Which index you choose to assess richness and abundance will depend on how well you are able to accurately cover the true diversity of the community.

A wide array of tools exist to measure the diversity of animal and plant communities, and new research is assessing their applicability to microbial communities. In general, these tools fall into three categories:

1. Indices of species richness (i.e., the number of species present)
2. Indices of species evenness (proportional abundance of different species, providing a picture of evenness/dominance of the community)
3. Species abundance distributions

Two of the more widely used species richness indices are the Shannon index ( $H'$ ) and Simpson index. The Shannon index is a measure of the degree of uncertainty in predicting

the identity of the next individual sampled in a community of  $S$  species and  $N$  individuals. It's influenced by the number of rare versus dominant species in a community because it gives more weight to rare species. If you do not have complete coverage of the species present, the Shannon index will be an underestimate. However, despite its problems, Hill et al. (2003) recommended it as one of the measures of diversity for microbial studies. In general, if you have not adequately sampled the species richness of a community, you will not get a reliable measure of diversity since richness is influenced by evenness. The coverage of your sampling can be assessed with rarefaction curves, using programs such as DOTUR (Schloss and Handelsman 2005). An overview of the more popular indices can be found in Molles (2008), and an assessment of their fit to microbial data can be found in Hill et al. (2003).

### 9.8.2 Connections between Metazoans and Microorganisms: Co-occurrence Patterns

Are patterns of species concurrence random or controlled by abiotic and biotic factors? Several researchers have proposed that competition is a major factor regulating what species occur simultaneously (see the discussion in Section 9.7.2), while others suggest that historical factors, biotic interactions such as mutualism or syntrophy, or different habitat requirements may play important roles. This is a key question that helps us understand the structuring of communities and to discover whether there are “rules” that govern the structuring of these assemblages. Do the rules of ecology elucidated for macroorganisms apply to microorganisms? Horner-Devine et al. (2007), in their analysis of co-occurrence patterns, are beginning to shed light on this question for both macro- and microorganisms. Species may co-occur or never co-occur [what Horner-Devine et al. (2007) term “permissible combinations” or “checkerboard distributions”] more often than expected by chance. By comparing microbial and macrobial species distributions using a null model analysis that predicts whether the patterns observed will have been created by chance, Horner-Devine et al. (2007) were able to ascertain that communities of microorganisms and macroorganisms show a great deal of similarity in their patterns. Their checkerboard distribution analyses help determine whether competition or preference for particular habitats are important factors in community assemblages. Two other analyses assessed the amount of concurrence or segregation in a given community: (1) Combo, which assesses the number of species combinations between sites, and (2) C-score, which evaluates the checkerboard units present versus what the null distribution would predict. Horner-Devine et al. (2007) revealed that microorganisms, like macroorganisms, show greater segregation than expected by chance. The striking result from their studies is the amount of congruence in patterns observed among microbial and macrobial communities. Do these categories of life, which differ tremendously in size, nature, and physiology, show this congruence because they are governed by similar processes or because of interdependences we don't fully understand? The underlying factors that create the patterns observed require much more experimental work to understand.

Besides considering the “normal” functioning of a microbial community, we need to look at the impact of disturbance on communities.

### 9.8.3 Disturbance and Diversity

What comes to mind when you hear the term “disturbance”—fire, hurricanes, deforestation, or disease? Disturbance can take many forms, but a basic ingredient in its definition is the effect on individuals, populations, communities, or ecosystems. Disturbance may

be an important factor in the patterns of species diversity that we observe in communities. Fire, storms, and human actions are all disturbance forces that alter the existing structure and/or physical environment of a community or ecosystem, leading to new colonization opportunities. Disturbance is an event that causes the death, displacement, or harm to individuals within a population, community, or ecosystem and leads to opportunities for new individuals to replace them.

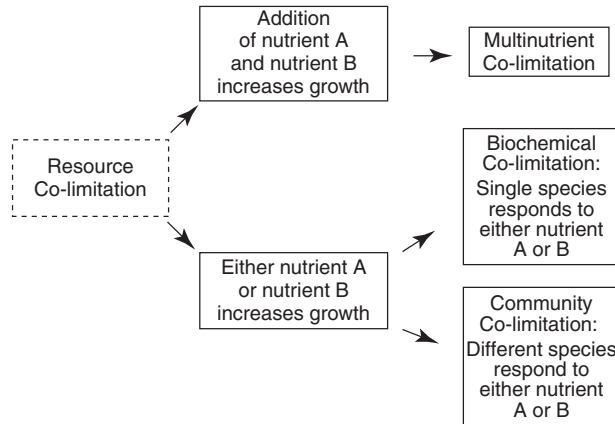
Hurricanes represent large-scale disturbance events. Yannarell et al. (2007) used the occurrence of Hurricane Frances, a category 4 storm, as a natural experiment to study the effects of disturbance on cyanobacterial mats on San Salvador. This mat community appeared to be in an equilibrium state before the hurricane, and changes in community composition and salinity in the equilibrium state did not change some ecosystem parameters, such as the C : N ratio. Hurricane Frances, however, greatly lowered salinity values and deposited layers of sand on the cyanobacterial mat communities, leading to dramatic shifts in community composition and C : N ratios, pushing them out of equilibrium. Dominant cyanobacterial species decreased, and more rare species existing prior to the hurricane, increased substantially in proportion. Despite the shift of the community from equilibrium, the community rapidly recovered. Perhaps the most important conclusion of this study is the support for the hypothesis that more diverse communities are better able to recover from massive disturbance, due to redundancy in function of community members. Thus, previously rarer species may take over ecosystem functions such as nitrogen fixation following major disturbances. This was seen in the study by Yeager et al. (2005) of the effects of a major fire on community composition of nitrogen fixers and ammonia oxidizers. Thus, redundancy contributes to ecosystem resilience. But what about intermediate levels of disturbance?

Disturbance can affect social traits such as cooperation and supports the contention that disturbance leads to coexistence. Brockhurst et al. (2007) suggested that cooperation can only evolve in situations in which disturbance is moderate. At low disturbance rates, although cell densities reach critical levels for cooperation to be beneficial, cheaters arise and gain a selective advantage, eventually dominating the population. At high disturbance rates cheaters predominate because mass mortality events prevent cell density from reaching a level in which cooperation is beneficial. This study dovetails with the more general hypothesis that intermediate levels of disturbance lead to greater diversity (Buckling et al. 2000), referred to as the *intermediate disturbance hypothesis* [IDH (Figure 9.7), proposed by Joseph Connell in the mid-1970s]. Moderate levels of disturbance facilitate higher species diversity due to tradeoffs between competition (competitive exclusion) and colonization. Many studies have failed to support IDH, leading Cadotte (2007) to examine the tradeoffs between competition and colonization at different scales. Cadotte showed that where species are on a gradient of colonization/competition, the resulting diversity is affected; differing levels of disturbance create a gradient of colonizers, while a gradient of time since disturbance creates a gradient of competition. He also showed that scale matters, demonstrating that the IDH holds at larger scales than the local patch. Type, frequency, and level of disturbance strongly affect community species diversity, but we still have much to learn about exactly how.

## 9.9 FOOD WEBS

A *food chain* is a representation of the flow of energy within a food web, from one to level to the next, showing the sequence of what is eaten by what. A *food web* represents feeding relationships within a community and linkages among food chains. Food chains





**Figure 9.8.** Replacing the more traditional view that one nutrient usually limits a population, new evidence now suggests that multiple nutrients limit organisms and even communities in several different ways as shown here [modified from Arrigo (2005)].

and food webs are important constructs in ecology. The author can still remember the excitement of the speaker at the Woods Hole Microbial Diversity course in 1993 as he introduced the idea of the widespread nature of picoplankton, a newly discovered component of the food web in Earth's oceans. Little did we know then how important the many yet to be discovered groups of microorganisms are in food webs. In fact, few studies even incorporated microorganisms into food web investigations.

Microorganisms represent important components of food webs (Section 4.4.1), and are depicted as the base of most food webs. Much of the ocean is occupied by photosynthetic microorganisms (Cyanobacteria and algae), Archaea, protozoans, and viruses whose diversity is just being uncovered (see also Section 4.3.2). Protozoans prey on the various bacterial components of the food web, limiting bacterial population sizes; those microorganisms that escape predation may fall victim to pathogenic viruses (Smetacek 2002). A few studies have examined predominately microorganisms in soil food webs (see Section 4.4.1) and microbial food webs or have constructed microcosms to study microbial food webs.

### 9.9.1 Structure of Microbial Food Webs

What affects the composition of food webs? Predation (top-down effect) and the availability of resources (bottom-up effect) can potentially affect species diversity within microbial communities. Yet, how does diversity within trophic levels affect how resource availability and predation effects are felt throughout the food web? Fox (2007) set up microcosm studies with bacteria as the resource base and different schemes of protist prey, and predators, varying from depauperate food webs to several levels of prey in a food web. He found that as he increased productivity in his systems, prey and predator biomass increased (bottom-up effects); if predators were present, prey biomass decreased and changed in composition, which, in turn, led to an increase in the bacterial resource base [top-down effects (Fox 2007)]. Now let's add another wrinkle to the discussion. What happens when the environment is more extreme, lowering diversity and possibly eliminating or decreasing top-down predation effects?

Microorganisms exist in a wide range of environmental conditions, including conditions of pH, temperature, and pressure that humans and other organisms consider extreme. These extreme conditions may result in lower species diversity and the absence of top predators and certain functional groups within the food web, but the full complexity of how extreme conditions affect food webs and food chains is still under study. By contrasting and comparing two acidic lakes ( $\text{pH} \leq 3$ ), which are species-poor with two neutral lakes of different productivities, Gaedke and Kamjunke (2006) were able to tease apart some of the effects of acidity and trophic state. The four lakes they chose differed in size, which did not seem to be a factor in the differences in food webs. Productivity differed markedly between the two neutral lakes. In the two acidic lakes, the third and fourth trophic levels were missing, but this was not attributed to productivity. Acidity clearly affected species richness (lower in the acidic lakes), the degree to which different functional groups were present, and the composition of consumers. However, the ratio of heterotrophs to autotrophs appeared to be more dependent on the degree to which a lake was oligotrophic to eutrophic (trophic state). Thus, in those lakes that are dominated by microorganisms to differing degrees, we can see that environmental stressors such as pH can affect the food web structure.

### 9.9.2 Keystone Species Effects on Food Webs and Diversity

The concept of keystone species was proposed in the 1960s by Robert Paine and suggests that predators can have profound effects on species diversity by keeping prey below their carrying capacity (Molles 2008). When prey species are kept below their carrying capacity, they do not competitively exclude their competitors, thus leading to increased species diversity. Because of their position in the food web, bacteria rarely function as predators, but are more often prey and therefore unlikely to function as keystone species. However, as a group, one might argue that they are limiting the carrying capacity of humans. Other microorganisms, including fungi and protists, function as predators within food webs.

## 9.10 PRIMARY PRODUCTION AND ENERGY FLOW

### 9.10.1 Cycling of Nutrients

Marine microorganisms are responsible for roughly half of Earth's primary production (Arrigo 2005)—that's a stunning statement! If we want to understand nutrient cycling, these are key organisms and communities to study. Marine phytoplankton include the microscopic algae and diatoms that float in the ocean and are responsible for the bulk of marine photosynthesis. Marine phytoplankton strongly influence the availability of nutrients in the oceans, and we are influencing these organisms and communities through anthropogenic activities such as nitrogen runoff into the oceans. The microorganisms shape nutrient availability and are, in turn, shaped by what nutrients are available. New discoveries since the 1990s have shown that these organisms and communities may be limited by multiple nutrients. Let's take a look at some of the complexities of this system, which is only now beginning to be understood.

Our oceans show a ratio of 16 : 1 of nitrogen to phosphorus, which corresponds to the average ratio seen in marine phytoplankton; this is called the *Redfield ratio*. Overall, our

oceans are markedly constant in terms of the elemental composition of nitrogen, carbon, and phosphorus, as reflected in the Redfield ratio. This chemical ratio in ocean waters mirrors the average seen in the ocean's phytoplankton. Scientists have shown that the Redfield ratio in our oceans actually represents an average of phytoplankton with greater (such as the nitrogen-fixing cyanobacteria) and lesser ratios of N : P in different phytoplankton.

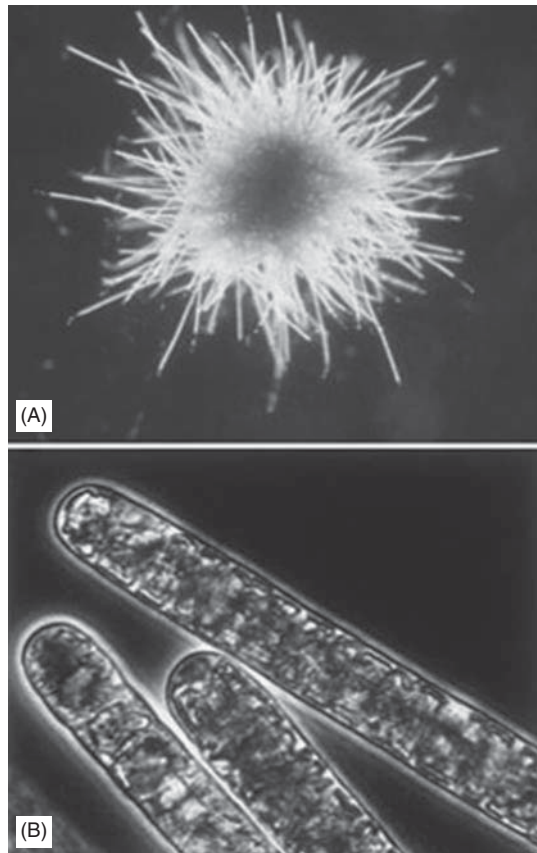
The traditional view that nutrient limitation was limited to one nutrient in a given organism or ecosystem has been replaced by the view that multiple nutrients limit growth. Arrigo (2005) defines and illustrates three types of resource colimitation (Figure 9.8). First is the instance in which two nutrients are simultaneously limiting as seen in limitation of diatom growth by low amounts of both phosphorus and silicon in the South China Sea. In the second and third types, multiple resources are limiting, but the addition of any one limiting nutrient provokes a growth response. This type of colimitation occurs at the cellular (biochemical) or community level, in which different populations in the community are limited by different nutrients. Colimitation illustrates our growing knowledge of the true complexity of communities and ecosystems. One of the most important of the potentially limiting nutrients is nitrogen.

Nitrogen is a critical element in the oceans as well as in terrestrial habitats, and its levels are a critical part of the Redfield ratio discussed above. Our understanding of the importance of nitrogen fixation and its controls in marine microorganisms has changed significantly since the 1990s (Figure 9.9; see also additional, more general information on the nitrogen cycle in Section 10.5). We have discovered that nitrogen fixation is more prevalent and accomplished by more organisms than the previous star of the show, *Trichodesmium* (Figure 9.9). Approximately 22–34 Tg of nitrogen are fixed per year by *Trichodesmium* [reported in Arrigo (2005)]. Iron, a key, and often limiting, nutrient for nitrogen fixation, is needed in lower levels than previously thought, and phosphorus in the form of phosphate may be a colimiting nutrient. How will global warming and resulting warming of the upper ocean change marine nitrogen fixation? What new surprises lie in store for researchers examining the cycling of nitrogen in our oceans?

One of the key pieces in the cycling of nitrogen in marine environments turned out to be a total surprise: the anaerobic conversion of ammonia to N<sub>2</sub> using nitrite as the oxidant, through a process called *anammox*. The discovery of this process elucidated an entirely new metabolic pathway carried out by members of the order Planctomycetales, and revealed a major process for removing biologically available nitrogen from the ocean. New studies are demonstrating that anammox may be responsible for a much larger portion of the production of N<sub>2</sub> than that contributed by denitrification (Arrigo 2005). Right on the heels of this discovery comes the finding that ammonia oxidation also is carried out by soil Archaea in a study by Leininger and colleagues, reviewed in Cavicchioli et al. (2006). From this work, it appears that archaeal *amoA* genes are more dominant in soils than are those of their bacterial counterparts. RNA studies show that these genes are proportionally active in the soil ecosystem as well. Thus, our understanding of the role of Archaea in nutrient cycling in various ecosystems is growing rapidly. Many opportunities exist for you as a future researcher to understand how microorganisms play major roles in nutrient cycling in our oceans and soils.

## 9.11 MICROBIAL COMMUNITY EXAMPLES

The following case studies of microbial communities provide strong rationales for studying microbial community interactions and composition through examples from marine

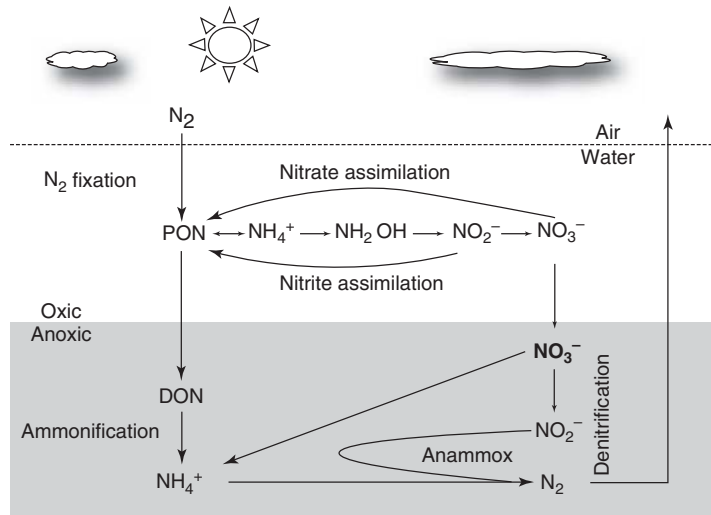


**Figure 9.9.** *Trichodesmium* is one of the major nitrogen fixers in the ocean. Image A is the conglomeration of many cells, while image B is several individual cells. (Images by John Waterbury, WHOI.). See insert for color representation.

plankton, wine and cheese and the great diversity of the microbial world as seen in hot springs.

### 9.11.1 Plankton in Marine Ecosystems

Planktonic Bacteria and Archaea float free or in aggregates in the oceans' waters and are generally found in relatively low abundances ( $10^5$  cells  $\text{mL}^{-1}$ ) compared to soil ecosystems. However, most of the marine biomass is microbial, and the sheer magnitude of the oceans indicates that they constitute a major portion of Earth's microbial diversity. Studies of marine communities are revealing many novel microbial groups, giving new insights into nutrient cycling, and revealing the basic tenets of ecology and adaptation in this environment. In general, ocean waters are oligotrophic and also lack abundant sources of fixed iron, nitrogen, and phosphorus (Giovannoni and Sting 2005). Through phylogenetic and metagenomic studies, we now know that the plankton in the ocean display patterns of vertical distribution, and that some groups are ubiquitous throughout the ocean. Photosynthesis and the oxidation of reduced organic matter are the key metabolic



**Figure 9.10.** Because nitrogen is often a limiting nutrient, understanding the cycling of nitrogen in the oceans is critically important [modified from Arrigo (2005)].

strategies of planktonic Bacteria and Archaea in the surface zone of the world's oceans. Phototrophs, such as the Cyanobacteria, occur in the upper photic zone, as well as the SAR86 Gammaproteobacteria, which may be phototrophic.

The area known as the “dark upper pelagic” zone contains several groups for which little information is known: SAR202, SAR406, and SAR324, as well as the better known marine group I Archaea that are hypothesized to be chemoautotrophs. Giovannoni and Sting (2005) suggest that these groups position themselves in this zone to catch nutrients descending from the abovementioned photic zone. In the coastal areas, which receive nutrients from upwelling zones, Betaproteobacteria tend to dominate the populations.

Another major finding from the study of marine communities is the possibly widespread occurrence of rhodopsin-based phototrophy, in which sunlight is used to drive a cellular proton pump. Rhodopsins such as bacteriorhodopsin and proteorhodopsin have been found to occur much more abundantly than previous thought, and these findings suggest that other forms of phototrophy are prominent in the oceans (Giovannoni and Sting 2005). Marine communities have much to reveal to us about basic microbial ecology.

### 9.11.2 Hot Springs

Earth's plate tectonics result in areas of hydrothermal venting, either below the ocean's surface at subduction zones, in spreading centers, or in hotspots (e.g., Hawai'i), and at Earth's surface in hot springs, such as the well-known examples in Yellowstone. Water percolates down through fissures in Earth's crust, picks up heat, and is geochemically altered by its passage through the crust. When the water emerges at hot springs or deep-sea hydrothermal vents (Figure 9.11), it is usually rich in dissolved gases and reduced minerals—a bonanza for microbial communities that live at these interfaces. By studying these communities, we are discovering many novel lineages, including new phyla; are identifying immensely useful enzymes such as Taq polymerase; and are gaining knowledge of how organisms can survive such hot temperatures physiologically.

Microbiologically, terrestrial hot springs are “hot” spots in terms of the diversity of microorganisms that they play host to—phototrophs often dominate, and a gradient of



**Figure 9.11.** Location of hydrothermal sites (terrestrial) (■) and deep-sea vents (○) [modified from Reysenbach and Cady (2001)].



**Figure 9.12.** Hot spring microbial mats contain a variety of phototrophs, chemolithotrophs, and heterotrophs; this hot spring at Soda Dam, New Mexico shows a variety of colors of microorganisms (photograph Kenneth Ingham, copyright 2007). See insert for color representation.

organisms follows gradients of temperature, pH (ranging from 1 to 10), and reduced minerals. The mats in the outfall of the upwelling spring water are often very colorful (Figure 9.12). One order that is found in many terrestrial hot springs is the *Aquificales*, whose members have been studied extensively by Anna-Louis Reysenbach (see the “microbial spotlight” in Chapter 5) and others. For example, the pink filaments found in Yellowstone hot springs have been identified as *Thermocrinis ruber*. This and other filamentous microorganisms in hot springs are often encrusted in iron, sulfur, and silica minerals, making them ideal candidates for studies of biosignatures to facilitate the recognition of microbial fossils in more ancient rocks on Earth and other planets. Biosignatures are characteristic morphologies or attributes (e.g., biominerals) found in rocks; they reveal the presence of microorganisms in the past.



### 9.11.3 Wine and Cheese

The production of many of our most beloved foods and beverages is assisted by communities of microorganisms. Interactions within these communities hold some microorganisms in check, while allowing others to flourish. Which ones win these battles determines whether humans find the taste of the product desirable or repulsive. We will highlight the microbial communities of wine and cheese, both economically important products that are highly molded by their microbial communities. This case study demonstrates the impact that the study of microbial ecology can have on human enterprises with very large economic impacts.

**Microbial Communities in Wine Production.** Wine production takes advantage of various species of yeasts and bacteria to carry out fermentations. Utilizing culture-independent molecular techniques, the laboratory of David Mills studies the changes in wine communities that take place (Cocolin et al. 2000; Neeley et al. 2005). Over time, wine develops pH conditions ( $>3.5$ ) and ethanol content that control what organisms can persist. Some of the organisms are indigenous, and some are added to the fermentation by humans. During alcohol fermentation, yeasts such as *Kloeckera*, *Metschnikowia*, *Candida*, *Hanseniaspora*, and *Saccharomyces* predominate. *Saccharomyces cerevisiae* increasingly dominates the assemblage as the ethanol content increases. Lactic acid bacteria (LAB), including species of *Lactobacillus*, *Pediococcus*, and *Oenococcus*, are important in wine because they can either enhance wine production by malolactic fermentation or can spoil the wine when undesirable species are present. Just as you choose a particular wine for a particular meal, the LAB of choice for malolactic fermentation is *Oenococcus oeni*. Microbial ecologists assist vintners by analyzing microbial communities during wine fermentation. A batch of wine spoiled by the wrong microbial community can cost the winery thousands of dollars.

**Cheese Microbial Communities.** An advertisement for cheeses made the following bold statement: “Textures so sexy you want to take the cheese to bed with you . . . . Obscenely rich and flavorful.”

What they don’t mention in the ad is that the essential ingredient for many cheeses is the community of starter and secondary (acquired later) microorganisms used in the preparation and aging of cheese and the interactions that occur among microorganisms (Figure 9.13). Cheesemaking includes a variety of microorganisms that begin the process (starters) or assist as the cheese ripens (secondary) (Beresford et al. 2001). Microbial community composition is affected by moisture levels, pH, and salt concentration. Ripening temperatures for cheeses try to strike a balance between what’s needed for good ripening and what will encourage the undesirable growth of secondary microorganisms, some of which may be pathogenic. Over time, the redox conditions go from an oxidizing environment to a reducing one, with the interior of the cheese becoming anaerobic. Thus, redox conditions strongly affect microbial composition within cheeses and limit the community to facultative or obligate anaerobes in the cheese interior.

Cheesemaking (Figure 9.14) begins with a group of microorganisms (starters) that are able to produce acid and reduce the pH of the cheese in a short period of time. These include some of the species shown in Table 9.1, some of which are present naturally in the milk used to make cheese. Several of these are lactic acid bacteria (LAB) that are known for their acid production. The subsequent lysis of these starter bacteria and the amino acids released are important steps in the development of cheese flavor. Secondary

## Microbial Spotlight

### DAVID MILLS



David Mills amid his sample collection.—(Photograph courtesy of G. Hirson, copyright 2006).

With retail sales totaling more than \$15 billion in 2005, the quality of California wines, the focus of David Mills' research, is of key importance to the state's financial health. The economic impact worldwide and the opportunities to discover new information, which is fundamental to producing flavorful wines and understanding the microbial roles in winemaking, has led David Mills to his research interest in fermentation: "At the end of the day, we can literally toast our research," he quips. What kinds of discoveries do you make when you study the microbial communities of wine? Touted as "the most romantic wine you have ever tasted," makers of Dolce dessert wines are keen to ensure the flavor and quality of their wines. To sort out the microbial black box that affects the taste of Dolce wine, Mills and his colleagues began a study. Their findings shed light on how the microorganisms present in the wine affect taste.

Perhaps the greatest eureka moment involved our use of molecular methods to profile a commercial botrytized wine fermentation (<http://www.dolcewine.com>). Because the grapes used for this type of wine are purposely infected with *Botrytis cinerea*, the sugars are concentrated in the grapes and the ensuing wine fermentations are a microbial zoo, with many yeast and bacterial species in the initial stages of the fermentation. Using molecular techniques we noticed right away that a specific *Candida zemplinina* strain persisted long after the fermentation finished. This was unusual since the thinking at the time was that the dominant *Saccharomyces cerevisiae* population consumes the grape sugars (glucose and fructose), produces ethanol, and pretty much wipes out all other competitors. Looking at the data, we decided to test sugar consumption preferences in the *Candida* strain and, to our surprise, found that it consumed only fructose and left the glucose behind. Thus the *Candida* species persisted in

these wine fermentations by selectively consuming fructose, a sugar less favored by *Saccharomyces*.

The presence of *Candida* species could affect the taste of the Dolce wine. Enthusiastic about being a teacher and a researcher, David notes: "One of the best things about being a scientist are those moments of discovery where you finally see through a cloud of data to reveal some thread of insight/clarity."

bacterial residents are often acquired through the environment and include other species of *Lactobacillus* and *Pediococcus*. The various bacteria and fungi present during cheese ripening form a complex community with many interactions, some stimulatory and some inhibitory. In some cheeses, such as cheddar, the organisms present during ripening make the difference between a flavorful cheese and one that is bitter. Understanding the



**Figure 9.13.** Goat cheese. Note the holes in the cheese that are the results of microbial waste products such as  $\text{CO}_2$  and  $\text{H}_2$  (courtesy of J. Shagam, copyright 2006). See insert for color representation.

**TABLE 9.1.** Microbial Species Involved in Cheese Production

Genera or Group	Stage of Cheese Production	Function
<i>Lactococcus</i>	Starter	Acid production during manufacture
<i>Streptococcus</i>	Starter	Acid production during manufacture
<i>Lactobacillus</i>	Starter	Acid production during manufacture
<i>Leuconostoc</i>	Starter	Acid production during manufacture
<i>Enterococcus</i>	Starter	Acid production during manufacture
Propionic acid bacteria	Secondary	Propionic acid fermentation, ripening
<i>Pediococcus</i>	Secondary	Ripening
<i>Penicillium roqueforti</i>	Secondary	Formation of blue veins
<i>Penicillium camemberti</i>	Secondary	Deacidification and texture changes
<i>Debaryomyces</i> and other yeast	Secondary	Deacidification, flavor, and texture development



**Figure 9.14.** Cheesemaking on the island of Pico in the Azores (photos courtesy of A. Dapkevicius).

microbial ecology of the cheese communities can ensure a better product and strongly influence the economic success of this industry.

## 9.12 SUMMARY

Studies since the 1970s have revealed that many areas of Earth that were thought to be devoid of life actually contain thriving communities of microorganisms that live in conditions that are extreme for humans, but quite habitable for the microorganisms that make their home there. Our previous preoccupation with studying planktonic microorganisms has been replaced by a focus on biofilms, including many on, or in, the human body. The study of processes associated with biofilm formation, such as quorum sensing, are providing important clues about how bacteria interact and communicate. Studies on how new habitats, such as the human newborn gut, become colonized are shedding light on the establishment of new communities. Once established, succession proceeds to change the makeup of the community, which may be structured by competition at broad and fine scales. What controls community microbial diversity in these habitats and those that are more familiar, such as soil, are areas of vigorous debate and study. Several new ways of measuring diversity are being developed to allow us to measure differences in species richness and abundance between communities during normal conditions and after disturbance. Disturbance can have major impacts on diversity of microbial communities and represents an active area of research. Major changes in our concept of the ocean's (and other habitats') food web have occurred since the 1990s as we recognize the major contribution of microorganisms to nutrient cycling. Our case studies of communities, such as those in wine and cheese, and hot springs, show that we've learned a lot about

a variety of fascinating communities, but you should also notice the glaring holes in our knowledge of microbial communities.

### 9.13 DELVING DEEPER: CRITICAL THINKING QUESTIONS

- Think about the different habitats represented by hot springs, the ocean, desert varnish, soil, and tree leaves. What environmental factors would be important to determine to assess what controls diversity in these environments?
- How and when is it effective to use culturing to study microbial community composition?
- In what ways are the microorganisms living in a biofilm similar to and different from humans living in a city?
- What are some biofilms that exist in your life and environment?
- Why do biofilms pose such a challenge to human health?
- How does quorum sensing work?
- By what means do microorganisms disperse to new habitats?
- What roles do competition activities play in structuring communities?
- Define the difference between species richness and species abundance and evenness measures.
- How does disturbance contribute to microbial community structure?
- What roles do microorganisms play in food webs?
- We looked at the role of microorganisms in making cheese and wine. What other foods and drinks are made through the help of microorganisms?

### BIBLIOGRAPHIC MATERIAL

#### Further Reading

- Arrigo KR (2005), Marine microorganisms and global nutrient cycles, *Nature* **437**:349–355.
- Costerton JW (2004), A short history of the development of the biofilm concept, in Ghannoum M, O'Toole GA, eds., *Microbial Biofilms*, Washington, DC: ASM Press, pp. 4–19.
- Ghannoum M, O'Toole GA (2004), *Microbial Biofilms*, Washington, DC: ASM Press.
- Giovannoni SJ, Sting U (2005), Molecular diversity and ecology of microbial plankton, *Nature* **437**:343–348.
- Haag A (2005), Whale fall, *Nature* **433**:566–567.
- Harrison JJ, Turner RJ, Marques LLR, Ceri H (2005), Biofilms, *Am. Sci.* **93**:508–515.
- Handelsman J (2004), Metagenomics: Application of genomics to uncultured microorganisms, *Microbiol. Molec. Biol. Rev.* **68**:669–685.
- Nataro JP, Cohen PS, Mobley HLT, Weiser JN (2005), *Colonization of Mucosal Surfaces*, Washington, DC: ASM Press.

#### Cited References

- Arrigo KR (2005), Marine microorganisms and global nutrient cycles, *Nature* **437**:349–355.
- Beresford TP, Fitzsimons NA, Brennan NL, Cogan TM (2001), Recent advances in cheese microbiology, *Int. Dairy J.* **11**:259–274.

- Botton S, van Heusden M, Parsons JR, Smidt H, van Straalen N (2006), Resilience of microbial systems towards disturbances, *Crit. Rev. Microbiol.* **32**:101–112.
- Branda SS, Vik Å, Friedman L, Kolter R (2005), Biofilms: The matrix revisited, *Trends Microbiol.* **13**:20–26.
- Brockhurst MA, Buckling A, Gardner A (2007), Cooperation peaks at intermediate disturbance, *Curr. Biol.* **17**:761–765.
- Buckley M, Roberts RJ (2007), *Reconciling Microbial Systematics and Genomics*, Washington, DC: American Academy of Microbiology.
- Buckling A, Kassen R, Bell G, Rainey PB (2000), Disturbance and diversity in experimental microcosms, *Nature* **408**:961–964.
- Cadotte MW (2007), Competition-colonization trade-offs and disturbance effects at multiple scales, *Ecology* **88**:823–829.
- Cavicchioli R, DeMaere MZ, Thomas T (2006), Metagenomic studies reveal the critical and wide-ranging ecological importance of uncultivated archaea: The role of ammonia oxidizers, *BioEssays* **29**:11–14.
- Cocolin L, Bisson LF, Mills DA (2000), Direct profiling of the yeast dynamics in wine fermentations, *FEMS Microbiol. Lett.* **189**:81–87.
- Costerton JW (2004), A short history of the development of the biofilm concept, in Ghannoum M, O'Toole GA, eds., *Microbial Biofilms*, Washington, DC: ASM Press, pp. 4–19.
- Coyne MS (1999), *Soil Microbiology: An Exploratory Approach*, Albany, NY: Delmar Publishers.
- DeLong EF, Karl DM (2005), Genomic perspectives in microbial oceanography, *Nature* **437**:336–342.
- Fox JW (2007), The dynamics of top-down and bottom-up effects in food webs of varying prey diversity, composition, and productivity, *Oikos* **116**:189–200.
- Gaedke U, Kamjunke N (2006), Structural and functional properties of low- and high-diversity planktonic food webs, *J. Plankton Res.* **28**:707–718.
- Giovannoni SJ, Sting U (2005), Molecular diversity and ecology of microbial plankton, *Nature* **437**:343–348.
- González JE, Keshavan ND (2006), Messing with bacterial quorum sensing, *Microbiol. Molec. Biol. Rev.* **70**:859–875.
- Harrison JJ, Turner RJ, Marques LLR, Ceri H (2005), Biofilms, *Am. Sci.* **93**:508–515.
- Hill TCJ, Walsh KA, Harris JA, Moffett BF (2003), Using ecological diversity measures with bacterial communities, *FEMS Microbiol. Ecol.* **43**:1–11.
- Jackson CR (2003), Changes in community properties during microbial succession, *Oikos* **101**:444–448.
- Horner-Devine MC, Silver JM, Leibold MA, Bohannan BJM, Colwell RK, Fuhrman JA, Green JL, Kuske CR, Martiny JBH, Muyzer G, Øverås L, Reysenbach A-L, Smith VH (2007), A comparison of taxon co-occurrence patterns for macro- and microorganisms, *Ecology*. **88**:1345–1353.
- Janssen PH (2006), Identifying the dominant soil bacterial taxa in libraries of 16S rRNA and 16S rRNA genes, *Appl. Environ. Microbiol.* **72**:1719–1728.
- Kolenbrander PE, Andersen RN, Blehert DS, Eglund PG, Foster JS, Palmer Jr RJ (2002), Communication among oral bacteria, *Microbiol. Molec. Biol. Rev.* **66**:486–505.
- Kurihara Y (2004), Stability in ecological microcosm, *Proc. Jpn. Acad. Series B* **80**:327–335.
- Miller MB, Bassler BL (2001), Quorum sensing in bacteria, *Annu. Rev. Microbiol.* **55**:165–199.
- Molles Jr MC (2008), *Ecology: Concepts and Applications*, 4th ed., New York: McGraw-Hill.
- Neeley ET, Phister TG, Mills DA (2005), Differential real-time PCR assay for enumeration of lactic acid bacteria in wine, *Appl. Environ. Microbiol.* **71**:8954–8957.



- Nocker A, Burr M, Camper AK (2007), Genotypic microbial community profiling: A critical technical review, *Microbial Ecol.* **54**:276–289.
- Plante CJ, Wilde SB (2004), Biotic disturbance, recolonization, and early succession of bacterial assemblages in intertidal sediments, *Microbial Ecol.* **48**:154–166.
- Pomeroy LR (2001), Caught in the food web: Complexity made simple? *Scientia Marina* **65**(Suppl. 2):31–40.
- Rappé MS, Giovannoni SJ (2003), The uncultured microbial majority, *Annu. Rev. Microbiol.* **57**:369–394.
- Reysenbach A-L, Liu Y, Banta AB, Beveridge TJ, Kirshtein JD, Schouten S, Tivey MK, Von Damm KL, Voytek MA (2006), A ubiquitous thermoacidophilic archaeon from deep-sea hydrothermal vents, *Nature* **442**:442–447.
- Reysenbach A-L, Cady SL (2001), Microbiology of ancient and modern hydrothermal systems. *Trends Microbiol.* **9**:79–86.
- Riesenfeld CS, Schloss PD, Handelsman J (2004), Metagenomics: Genomic analysis of microbial communities, *Annu. Rev. Genetics* **38**:525–552.
- Rickard AH, Gilbert P, High NJ, Kolenbrander PE, Handley PS (2003), Bacterial coaggregation: an integral process in the development of multi-species biofilms, *Trends Microbiol.* **11**:94–100.
- Scheu S (2002), The soil food web: Structure and perspectives, *Eur. J. Soil Biol.* **38**:11–20.
- Schloss PD, Handelsman J (2005), Introducing DOTUR, a computer program for defining operational taxonomic units and estimating species richness, *Appl. Environ. Microbiol.* **71**:1501–1506.
- Sleator RD, Shortall C, Hill C (2008), Metagenomics, *Lett. Appl. Microbiol.* **47**:361–366.
- Smetacek V (2002), The ocean's veil: Microbial food webs, *Nature* **419**:565.
- Smith CR, Baco AR (2003), Ecology of whale falls at the deep-sea floor, *Oceanogr. Marine Biol. Annu. Rev.* **41**:311–354.
- Torsvik V, Sørheim R, Goksøyr J (1996), Total bacterial community diversity in soil and sediment communities—a review, *J. Industr. Microbiol.* **17**:170–178.
- West NP, Sansonetti PJ, Frankel G, Tang CM (2003), Finding your niche: what has been learnt from STM studies on GI colonization, *Trends Microbiol.* **11**:338–344.
- West NP (2003), Finding your niche: what has been learnt from STM studies on GI colonization, *Trends Microbiol.* **11**:338–344.
- Woese CR (1987), Bacterial evolution, *Microbiol. Rev.* **51**:221–271.
- Yannarell AC, Stepe TF, Paerl HW (2007), Disturbance and recovery of microbial community structure and function following Hurricane Frances, *Environ. Microbiol.* **9**:576–583.
- Yeager CM, Northup DE, Grow CC, Barns SM, Kuske CR (2005), Changes in nitrogen-fixing and ammonia-oxidizing bacterial communities in soil of a mixed conifer forest after wildfire, *Appl. Environ. Microbiol.* **71**:2713–2722.
- ZoBell CE (1943), The effect of solid surfaces upon bacterial activity, *J. Bacteriol.* **46**:39–56.

## Internet Sources

<http://www.erc.montana.edu/>.

## MICROBIAL PROCESSES CONTRIBUTING TO BIOGEOCHEMICAL CYCLES

---

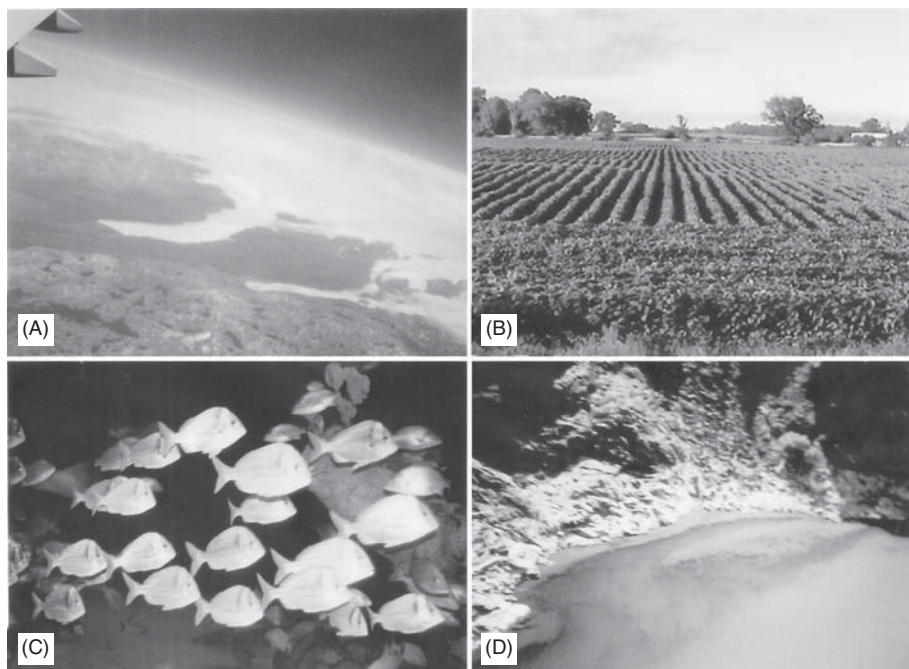
### 10.1 CENTRAL THEMES

- Microorganisms are active participants in elemental cycling because they couple energy flow in redox reactions to biosynthesis.
- Microorganisms have an indispensable role in global carbon cycling.
- Bacteria are important in the global nitrogen cycle in that they fix nitrogen, produce amino acids from different nitrogen sources, and participate in denitrification.
- Microorganisms mobilize phosphorus in the environment through the use of enzymes to release inorganic phosphate from phosphate esters and phosphonates.
- Bacteria and fungi have developed siderophore systems to solubilize and import iron from environmental sources.
- Microorganisms are active in cycling of sulfur, manganese, selenium, and numerous other redox-active elements.
- The movement of hydrogen as  $H^+$  in membrane activities, the metabolism of organic compounds with hydrogen, and the metabolism of  $H_2$  are important contributions of bacteria.

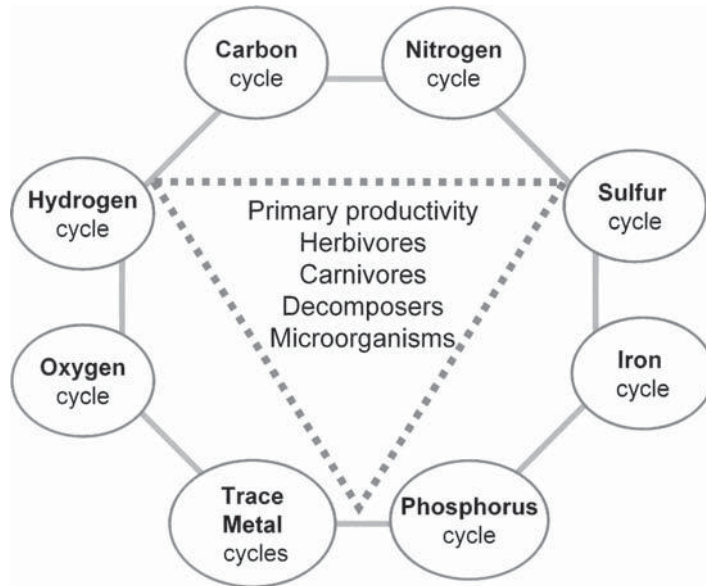
## 10.2 INTRODUCTION

While geomicrobiology is the study of microorganism as influenced by the geologic environment and geochemical processes, biogeochemistry is an interdisciplinary systems approach to study atmospheric, environmental, and Earth sciences. Biogeochemistry studies the composition of the biosphere by examining the relevant nutrient cycles and the impact of energy relationships on the natural environment. Vladimir Vernadsky, a Russian geochemist, is credited with starting biogeochemistry with the book *The Biosphere*, published in 1926. Subsequent studies by many scientists have focused on biotic and abiotic activities associated with energy and material processes.

As one views images of the environment, one can appreciate the complex interaction between biological systems and cycling of minerals. As inferred from the scenes in Figure 10.1, biogeochemical cycles involve atmospheric, terrestrial, and aquatic environments. While all these environments support microorganisms and higher forms of life, the rates of nutrient cycling will vary considerably. As a result of diverse metabolic activities, microorganisms have a great influence on chemicals in the environment including elements used to produce cellular biopolymers. Microorganisms have considerable influence on the biogeochemical cycling of elements in both anaerobic and aerobic environments



**Figure 10.1.** Environmental scenes focusing on the environment where activities underscore processes of the biogeochemical cycles: (A) the melting of Arctic ice may impact the flux of minerals in the atmosphere; (B) fixing of  $\text{CO}_2$  and  $\text{N}_2$  in a bean field in the midwestern United States; (C) cycling of nutrients in the ocean sustains fish; (D) algal bloom attributed to *Aphanizomenon flos-aquae* in Eagle Nest Lake, New Mexico reflects interaction with the N and C cycles (photographs by Larry Barton). See insert for color representation.



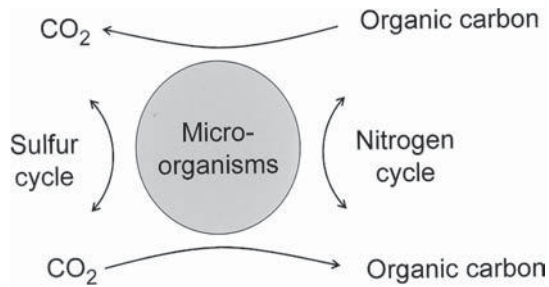
**Figure 10.2.** Microbial interaction with several biogeochemical cycles. The collective activities of microorganisms stimulate the cycling of elements through oxidation–reduction reactions.

(Figure 10.2). The importance of hydrogen, oxygen, carbon, nitrogen, phosphorus, and sulfur in cells of algae and bacteria is reflected by their abundance (see Table 10.1). Microorganisms acquire carbon, nitrogen, sulfur, and phosphorus from the environment to make carbohydrates, proteins, nucleic acids, and other organic molecules; in addition, these elements are released back into the environment on death of the microorganisms. This assimilation of nutrients to couple the release of nutrients from cells with cell decay is one component of nutrient cycling. However, there is another dimension of nutrient cycling that reflects the wide capability of bacteria to couple metabolism of inorganic nitrogen and sulfur compounds to energy production for biosynthesis. Heterotrophic microorganisms obtain energy from the metabolism of organic compounds, and chemolithotrophic sulfur or nitrogen bacteria use inorganic compounds as either

**TABLE 10.1.** Major Elements Present in the Cells of Microorganisms

Element	Abundance (g/100 g Dry Weight Cells)	
	Algae	Bacteria
Hydrogen	7.2	8.0
Oxygen	48.3	20.0
Carbon	33.6	50.0
Nitrogen	6.2	15.0
Sulfur	1.1	1.1
Phosphorus	0.8	3.2

*Source:* Barton et al. (2007).



**Figure 10.3.** Microorganisms collectively interact with the C, N, and S biogeochemical cycles.

electron donors or electron acceptors. Microorganisms have considerable impact on the C, N, and S cycles (see Figure 10.3). Additionally, anoxygenic photosynthetic bacteria use reduced inorganic sulfur compounds as an electron source. The multiple oxidation states for nitrogen ( $-3, 0, +1, +3, +5$ ) and sulfur ( $-2, 0, +2, +4, +6$ ) provide an opportunity for physiological groups of bacteria to obtain energy from specific reactions involving electron flow. Some chemolithotrophic bacteria contribute to metal cycling by using iron, manganese, and a few other metals in their electron transport systems. Energy-yielding reactions supporting bacterial growth are listed in Table 10.2.

As a result of many different metabolic activities of bacteria and their broad distribution, bacteria have considerable impact on local nutrient cycles. With the production of volatile compounds by terrestrial and aquatic microbes, regional metabolic processes have a global effect on redistribution of elements. This chapter addresses some of the microbial influences on the major biogeochemical cycles.

### 10.3 ENERGY FLOW

All life forms, including microorganisms, require energy to grow, and the processing of energy from the surrounding environment is one of the areas known as *bioenergetics*. Energy transformation from molecular interactions to cellular response follows the laws of thermodynamics, and Josiah Gibbs established a procedure for predicting the activity of a reaction. The free energy of a reaction is expressed as  $\Delta G$  ( $G$  for Gibbs), with a negative  $\Delta G$  indicating that the reaction can occur spontaneously and a positive  $\Delta G$  indicating that energy is required to make the reaction proceed. Since the free energy for hydrolysis of ATP is known ( $-31.8$  kJ/mol or about  $-8$  kcal/mol), the  $\Delta G$  of the reaction can be used to predict whether sufficient energy is released to synthesize ATP. The reactions listed in Table 10.2 all release sufficient energy to account for the formation of at least one ATP. The energy-yielding reactions consist of sets of enzymes with one enzyme involved in catalyzing the oxidation (removal of electrons) of a substrate and a different enzyme participating in the reduction (acceptance of electrons) of a different substrate. With hundreds of possible substrates as electron donors and hundreds of possible electron acceptors, there is tremendous potential for interactions of nutrients from different biogeochemical cycles. This is especially noteworthy with the nitrogen and sulfur cycles because compounds of these elements have diverse oxidation states (valence of elements). Thus, microorganisms that have the appropriate enzymes for oxidation–reduction reactions would be a source of energy for various segments of the biogeochemical cycles.

TABLE 10.2. Energy-Yielding Reactions Supporting Growth of Microorganisms

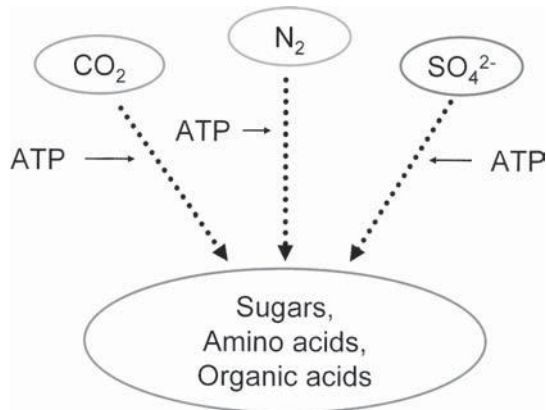
Substrate	Product	Energy Yield (kJ) <sup>a</sup> ( $\Delta G^{\circ}$ = kJ/Reaction)
<i>Carbon Cycle</i>		
1. Glucose + 6 O <sub>2</sub>	→ 6 H <sub>2</sub> O + 6 CO <sub>2</sub>	-2870.0
2. Glucose	→ 2 ethanol + 2 CO <sub>2</sub>	-238.8
3. Glucose	→ 2 lactate <sup>-</sup> + 2H <sup>+</sup>	-196.0
4. CO <sub>2</sub> + 4 H <sub>2</sub>	→ CH <sub>4</sub> + 2 H <sub>2</sub> O	-136.0
5. 4 H <sub>2</sub> + 2 CO <sub>2</sub>	→ acetic acid + 2 H <sub>2</sub> O	-104.8
6. H <sub>2</sub> + fumarate <sup>-</sup>	→ succinate <sup>-</sup>	-86.2
7. Acetic acid	→ CH <sub>4</sub> + CO <sub>2</sub>	-37.0
<i>Nitrogen Cycle</i>		
8. Glucose + 8 NO <sub>2</sub> <sup>-</sup> + 8 H <sup>+</sup>	→ 6 CO <sub>2</sub> + 4 N <sub>2</sub> + 10 H <sub>2</sub> O	-3144.0
9. 3 H <sub>2</sub> + NO <sub>2</sub> <sup>-</sup> + 2 H <sup>+</sup>	→ NH <sub>4</sub> <sup>+</sup> + 2 H <sub>2</sub> O	-436.8
10. NH <sub>3</sub> + 2 O <sub>2</sub>	→ NO <sub>2</sub> <sup>-</sup> + 2 H <sup>+</sup> + H <sub>2</sub> O	-266.7
<i>Sulfur Cycle</i>		
11. S <sup>2-</sup> + 2 O <sub>2</sub>	→ SO <sub>4</sub> <sup>2-</sup>	-790.5
12. S <sup>0</sup> + 1.5 O <sub>2</sub> + H <sub>2</sub> O	→ SO <sub>4</sub> <sup>2-</sup> + 2 H <sup>+</sup>	-580.9
13. 4 H <sub>2</sub> + SO <sub>4</sub> <sup>2-</sup>	→ HS <sup>-</sup> + 3 H <sub>2</sub> O + OH <sup>-</sup>	-152.0
14. Acetate <sup>-</sup> + SO <sub>4</sub> <sup>2-</sup> + 3 H <sup>+</sup>	→ 2 CO <sub>2</sub> + HS <sup>-</sup> + 2 H <sub>2</sub> O + H <sup>+</sup>	-57.5
15. H <sub>2</sub> + S <sup>0</sup>	→ HS <sup>-</sup> + H <sup>+</sup>	-29.0
<i>Iron Cycle</i>		
16. Acetate <sup>-</sup> + 8 Fe <sup>3+</sup> + 4 H <sub>2</sub> O	→ 2 HCO <sub>3</sub> <sup>-</sup> + 8 Fe <sup>2+</sup> + 9 H <sup>+</sup>	-233.0
17. Fe <sup>2+</sup> + 0.25 O <sub>2</sub> + H <sup>+</sup>	→ Fe <sup>3+</sup> + 0.25 H <sub>2</sub> O	-44.2
<i>Manganese Cycle</i>		
18. MnO <sub>2</sub> + 4 H <sup>+</sup> + 2 e <sup>-</sup>	→ Mn <sup>2+</sup> + 2 H <sub>2</sub> O	-77.3
19. Mn <sup>2+</sup> + 0.5 O <sub>2</sub> + H <sub>2</sub> O	→ MnO <sub>2</sub> + 2 H <sup>+</sup>	-70.9
<i>Selenium Cycle</i>		
20. Lactate <sup>-</sup> + 2 SeO <sub>4</sub> <sup>2-</sup>	→ acetate <sup>-</sup> + 2 SeO <sub>3</sub> <sup>2-</sup> + HCO <sub>3</sub> <sup>-</sup> + H <sup>+</sup>	-343.1
21. Lactate <sup>-</sup> + 2 SeO <sub>3</sub> <sup>2-</sup> + H <sup>+</sup>	→ acetate <sup>-</sup> + 2 Se <sup>0</sup> + HCO <sub>3</sub> <sup>-</sup> + H <sub>2</sub> O	-529.5
<i>Arsenic Cycle</i>		
22. Lactate <sup>-</sup> + 2 AsO <sub>4</sub> <sup>2-</sup> + H <sup>+</sup>	→ acetate <sup>-</sup> + 2 H <sub>2</sub> AsO <sub>3</sub> <sup>-</sup> + HCO <sub>3</sub> <sup>-</sup>	-140.3
23. Lactate <sup>-</sup> + 2 H <sub>2</sub> AsO <sub>3</sub> <sup>-</sup>	→ acetate <sup>-</sup> + 2 AsH <sub>3</sub> + HCO <sub>3</sub> <sup>-</sup> + H <sup>+</sup>	-138.4

<sup>a</sup>High-energy phosphate bond in ATP is -31.8 kJ or ~8 kcal.

Source: Barton (2005).

While light-driven processes would energize photosynthetic microorganisms and would be a major global energy source, energy obtained from inorganic transformations would enable microorganisms to grow in obscure environments. Some reactions in the biogeochemical cycles are energy-requiring (Figure 10.4, Table 10.3 and Table 10.4), where bacteria use ATP to promote the reactions.





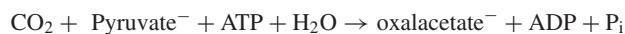
**Figure 10.4.** The synthesis of biomolecules from inorganic forms of N, S, and C requires energy for reduction and enzymatic processes.

**TABLE 10.3.** Energy Demands in Reactions Involving CO<sub>2</sub> Fixation by Bacteria

1. Ribulose-1,5-bisphosphate carboxylase (used by cyanobacteria, algae, and most autotrophs):



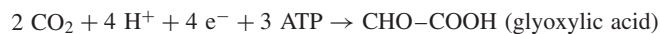
2. Pyruvate carboxylase (used by *Arthrobacter globiformis* and yeasts):



3. Reductive citric acid pathway (used by *Chlorobium limicola*, *Hydrogenobacter thermophilus*, and *Desulfobacter hydrogenophilus*):



4. Hydroxypropionate pathway (used by *Chloroflexus*):



5. Phosphoenolpyruvate carboxylase (used by *E. coli* and *Salmonella typhimurium*):

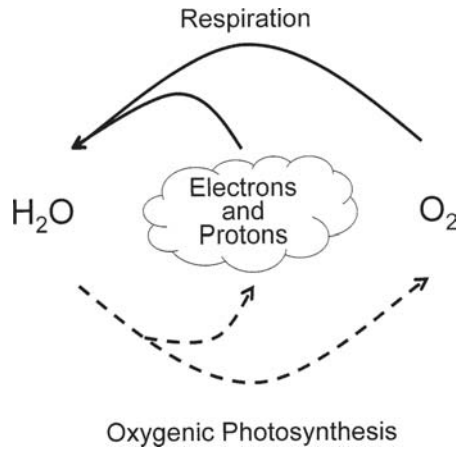


6. Ljungdahl–Wood pathway or reductive acetyl–CoA pathway (used by *Acetogenium kivui*, *Clostridium thermoaceticum*, *Desulfobacterium autotrophicum*, and *Methanosarcina barkeri*):



## 10.4 OXYGEN AND CARBON CYCLING

Water is the source of oxygen for O<sub>2</sub>, and the aerobic atmosphere of Earth is produced by continuous photosynthetic processes. When O<sub>2</sub> production initially occurred on Earth, there were no aerobic organisms and molecular oxygen accumulated. A robust collection of biological systems evolved to consume O<sub>2</sub> through respiration, and currently there is equilibrium between O<sub>2</sub> production and O<sub>2</sub> consumption. When compared to other elements, the oxygen cycle (Figure 10.5) is relatively simple. Large numbers



**Figure 10.5.** The cycling of oxygen. Solid lines indicate reduction; dashed lines indicate oxidation. Heterotrophic and chemolithotrophic microorganisms associated with the use of oxygen as the terminal electron acceptor. Cyanobacteria were associated with the photosynthetic release of molecular oxygen from water.

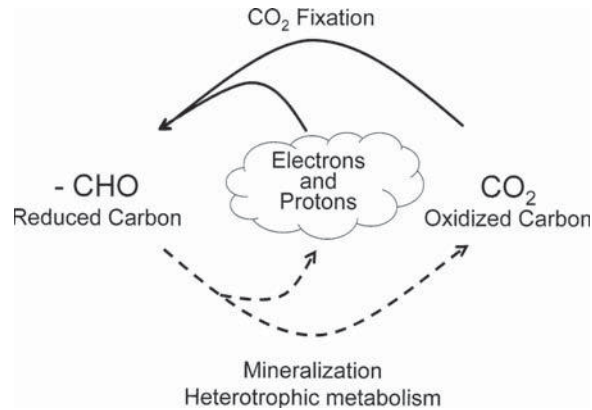
of microorganisms interface with the oxygen cycle through redox reactions. There is an interconnection between the oxygen and carbon cycles because oxygen reserves are found in organic compounds and  $\text{CO}_2$ .

With carbon as a principal element in cell systems, it would follow that distribution, fluxes, and reserves of carbon would be of global interest. Microorganisms have an important role in all aspects of the carbon cycle (see Table 10.4 and Figure 10.6).

Primary producers are the organisms that fix carbon dioxide, and while higher plants are important in terrestrial areas, algae and cyanobacteria account for primary productivity in marine environments. Nonphotosynthetic fixation of carbon dioxide

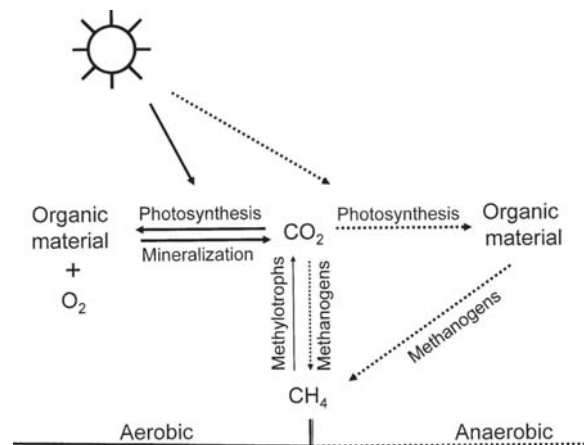
**TABLE 10.4.** Energy-Requiring Reactions of Nitrogen and Sulfur Cycles

<i>Nitrogen Metabolism</i>	
1. Nitrogen fixation (used only by prokaryotes; see Figure 10.9):	$\text{N}_2 + 8 \text{H}^+ + 8 \text{e}^- + 16 \text{ATP} \rightarrow 2 \text{NH}_3 + \text{H}_2 + 16 \text{ADP} + 16 \text{P}_i$
2. Glutamine synthetase:	$\text{L-Glutamate} + \text{NH}_4^+ + \text{ATP} \rightarrow \text{L-glutamine} + \text{ADP} + \text{P}_i$
<i>Sulfate Metabolism</i>	
3. ATP sulfurylase (used by most microorganisms):	$\text{SO}_4^{2-} + \text{ATP} \rightarrow \text{PP}_i + \text{APS}$
4. Assimilatory sulfate reduction (used by most microorganisms):	$\text{APS} + \text{ATP} \rightarrow \text{ADP} + \text{PAPS}$ (phosphoadenosyl sulfate) $\text{PAPS} + \text{thioredoxin}_{(\text{reduced})} + 6 \text{ferredoxin}_{(\text{reduced})} + \text{O-acetylserine} \rightarrow$ $\text{cysteine} + \text{thioredoxin}_{(\text{oxidized})} + 6 \text{ferredoxin}_{(\text{oxidized})} + \text{PAP}$
5. Dissimilatory sulfate reduction (used by <i>Desulfovibrio</i> and other sulfate-reducing bacteria):	$\text{APS} + 3 (2 \text{e}^- + 2\text{H}^+) \rightarrow \text{AMP} + \text{HS}^- + \text{H}^+$

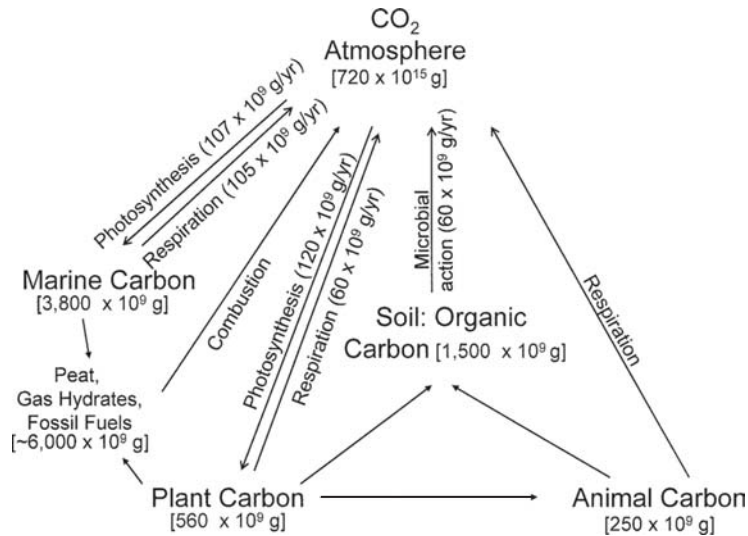


**Figure 10.6.** Redox reactions associated with the carbon cycle requires the cycling of electrons.

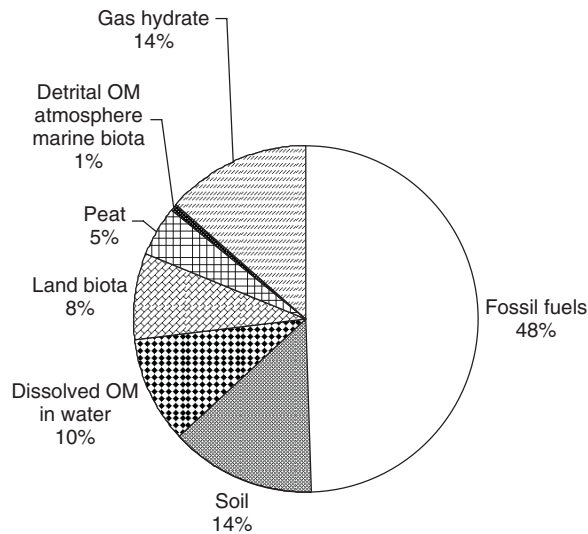
by chemolithotrophic or heterotrophic bacteria accounts for relatively small amounts of carbon transferred from the atmosphere to biomass. Large quantities of carbon are dissolved in ocean water as bicarbonate ion ( $\text{HCO}_3^-$ ), and comparable quantities of primary productivity occur in marine and terrestrial systems. Different groups of microorganisms are used for the cycling of C under aerobic and anaerobic conditions (Figure 10.7). A biogeochemical cycle involving major groups of microorganisms is shown in Figure 10.8. Soil is a great reservoir for carbon with appreciable quantities of complex organic material known as *humus* is stable with a very low turnover rate. Although carbon dioxide is released from plants and animals by respiration, great quantities of carbon dioxide result from decomposition of organic matter by microorganisms. Methane is produced by anaerobic archaea, and the resulting methane hydrates produced may account for a considerable percentage of total carbon on Earth (see Figure 10.9). Oxidation of methane with production of carbon dioxide is attributed to aerobic bacteria. Carbon monoxide is produced by a few bacteria as a result of decomposition, and this gas does not become toxic because aerobic bacteria readily oxidize carbon monoxide to carbon dioxide.



**Figure 10.7.** Microbial metabolism of carbon under anaerobic and aerobic conditions.



**Figure 10.8.** Biogeochemical carbon cycle; major reservoirs are indicated with quantity of carbon given [shown in brackets] and flux values as listed (shown in parentheses) [modified from Schlesinger (1991) and Holmen (1992)].



**Figure 10.9.** Distribution of organic carbon on Earth; considerable variation in estimation of gas hydrates occurs because of the model used (OM = organic matter) [modified from Milkov (2004)].

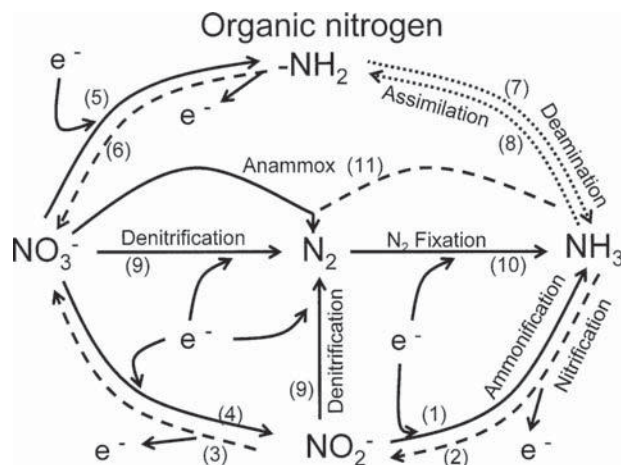
### 10.5 NITROGEN CYCLING

Microorganisms require nitrogen to make up 10% of their cellular composition, and the activities of bacteria also can have considerable influence on the nitrogen cycle. The principal reservoir for nitrogen is the atmosphere. According to the amount of organic

nitrogen, land organisms contain about  $5 \times 10^{15}$  g N, soil contains  $6.5 \times 10^{15}$  g N, and oceans contain about  $8 \times 10^{17}$  g N (Schlesinger 1991). Approximately  $1.7 \times 10^{14}$  g N per year are converted to  $\text{NH}_3$  by nitrogen-fixing prokaryotes as either free-growing or as symbiotic bacteria and in comparison, lightning combustion accounts for about  $1.9 \times 10^{13}$  g N fixed per year. When one considers the global cycle of nitrogen (see Figure 10.10) and the rates of conversions, the amount of time that a nitrogen molecule would be present in the organic form is about 370 years.

### 10.5.1 Nitrogen Fixation

One important aspect of the nitrogen cycle is *biological nitrogen fixation*, which is the conversion of atmospheric  $\text{N}_2$  to ammonia by prokaryotes. The enzymology for this reaction is unique in that the reduction of the triple bond between nitrogen atoms requires nitrogenase, which is activated by an electron donor (e.g., pyruvate). Electrons are transferred to the nitrogen atoms by a special iron–molybdenum complex. At least 16 ATP are required to energize the substrate–enzyme complex, making this an extremely energy-expensive reaction (see Table 10.4). A feature that is poorly understood is that nitrogenase releases one molecule of  $\text{H}_2$  along with two molecules of  $\text{NH}_3$ . Nitrogenase with the FeMo metal center is the most common enzyme; however, some bacteria produce alternate enzymes containing iron plus vanadium or only iron. These alternate enzymes are produced when molybdenum or vanadium are limiting in the environment, and this underscores the importance of nitrogen fixation to support prokaryotic growth. Bacteria that fix nitrogen are shown in Figure 10.11.



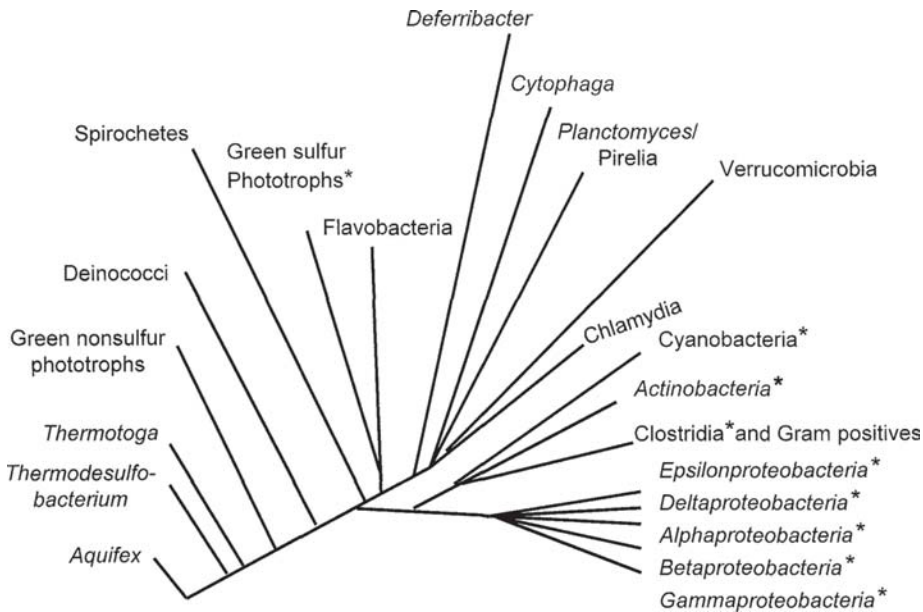
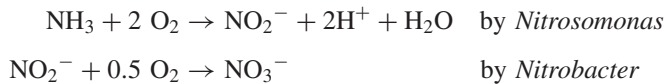
**Figure 10.10.** The role of microorganisms in the nitrogen cycle. Solid lines indicate reduction, dashed lines indicate oxidation, and dotted lines indicate no change in oxidation state of N. Microorganisms associated with the following reactions: (1) many organisms; (2) *Nitrosomonas*; (3) *Nitrobacter*; (4) *E. coli* and many other bacteria; (5) assimilatory reduction by many organisms; (6) oxidative deamination; (7, 8) many organisms; (9) *Bacillus*, *Paracoccus*, and *Pseudomonas*; (10) aerobic—*Azotobacter*, cyanobacter; anaerobic—*Clostridium* and anaerobic photosynthetic bacteria; symbiotic—*Rhizobium*, *Bradyrhizobium*, and *Frankia*; (11) *Brocadia* sp.

### 10.5.2 Nitrogen Assimilation

While nitrogen fixation is limited to a few species of prokaryotes, most microorganisms can readily assimilate  $\text{NH}_3$  into amino acids and other organic compounds. The release of  $\text{NH}_3$  from organic nitrogen compounds, known as *mineralization*, is attributed to enzymatic deamination reactions found in many microbial cells. Nitrogen is used by living systems for the synthesis of amino acids, nucleic acid bases, and various organic nitrogen compounds. The nitrogen source for animals is amino acids; for plants it is nitrate; and for bacteria it may be nitrate, ammonia, or dinitrogen. If ammonium ion is available, microorganisms will assimilate ammonium to form amino acids. The conversion of  $\text{N}_2$  to  $\text{NH}_3$  requires at least 16 mol ATP for each mole of  $\text{N}_2$  fixed, and for each mole of L-glutamine formed, one mole of ATP is required (see Table 10.4). However, if nitrate is the nitrogen source nitrate must first be reduced to ammonium, and this reduction process is referred to as *assimilatory nitrate reduction*. There are a series of interconversions of inorganic nitrogen compounds involving ammonia, nitrite, and nitrate.

### 10.5.3 Nitrification

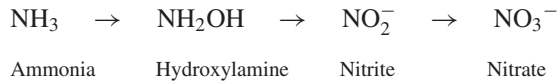
Ammonia is oxidized to nitrate by aerobic organisms using a multistep process as given below, and this process is especially important in soil because plants use nitrate as the nitrogen source:



**Figure 10.11.** A phylogenetic tree showing major groups of Bacteria; nitrogen fixation has been reported for bacteria in the groups indicated with an asterisk (\*) [modified from Buchanan et al. (2000)].



The steps in ammonia oxidation to nitrate proceed with numerous intermediates as shown below:



Each step in the nitrification sequence shown above is mediated by a specific enzyme. The initial step in aerobic oxidation by ammonia monooxygenase (AMO) that is a unique enzyme because it has three substrates: gaseous  $\text{NH}_3$  and  $\text{O}_2$  plus the electron donor.

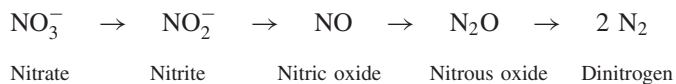
In anaerobic environments, denitrification occurs where nitrate is the electron acceptor with the formation of dinitrogen ( $\text{N}_2$ ). While some bacteria can reduce nitrate completely to nitrite, others are capable of reduction of nitrate only to nitrite. Anaerobic bacteria, including *Desulfovibrio* and *Clostridium*, will enzymatically reduce nitrite to ammonia. More recently there was a demonstration of the anammox (anoxic ammonia oxidation) reaction where bacteria convert ammonia and nitrate to dinitrogen by the following reaction:



This anammox reaction releases energy ( $\Delta G^{\circ'} = -357 \text{ kJ}$ ) that provides enough energy for autotrophic growth of the anaerobe *B. anammoxidans*.

#### 10.5.4 Denitrification

Denitrification is an important process in which nitrate serves as the electron acceptor for anaerobic bacteria with the release of nitrogen from the environment as  $\text{N}_2$ . Strains of *Pseudomonas* are often associated with denitrification reactions in the soil and contribute to the loss of nitrogen as a plant nutrient in flooded fields. The pathway for nitrate reduction is a stepwise reduction of the nitrogen atom with intermediates of nitrogen oxides as shown below:



Each of these steps in the reduction of nitrate to dinitrogen releases sufficient energy to support bacterial growth on that specific reaction. The denitrification pathway is also referred to as *dissimilatory nitrate reduction* because nitrate or nitrogen oxides are final electron acceptors that enable bacteria to grow.

### 10.6 SULFUR CYCLING

Sulfur, an element with multiple oxidation states, is required by biological systems with one gram of bacteria requiring about 11 mg of sulfur for synthesis of sulfur-containing amino acids. Earth's surface contains about 0.1% sulfur, and the sulfur cycle reflects the turnover of sulfur compounds in the environment (see Figure 10.12). It has been estimated that 90 million tons of sulfur enters the atmosphere from biologically produced

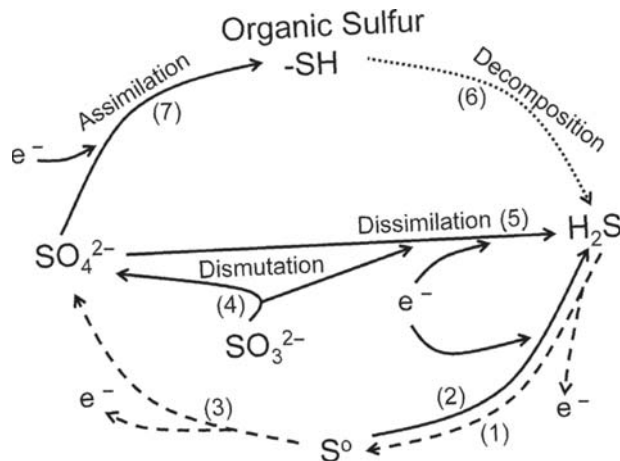
$\text{H}_2\text{S}$ ,  $\text{CS}_2$ ,  $\text{COS}$ , and  $(\text{CH}_3)_2\text{S}$ , while 50 and 0.7 million tons of sulfur are released into the atmosphere from burning fossil fuels and volcanic activity, respectively (Stanier et al. 1986).  $\text{H}_2\text{S}$  in the atmosphere is oxidized to  $\text{SO}_2$ , and when it rains, sulfur dioxide forms sulfurous acid ( $\text{H}_2\text{SO}_3$ ). A small amount of  $\text{H}_2\text{S}$  is oxidized to  $\text{SO}_3$  in the atmosphere and returns to Earth as  $\text{H}_2\text{SO}_4$ . Some have estimated that each year Earth may receive  $10^{14}\text{g}$  S as acid rain.

### 10.6.1 Organic Sulfur Metabolism

Microorganisms and plants can synthesize all sulfur-containing amino acids from sulfate, and this process is energy-dependent as shown in Table 10.4. In order for sulfate to be incorporated into cysteine, the sulfur atom must be reduced from +6 to -2, and this process has been designated as *assimilatory sulfate reduction*. Reduced sulfur (-SH or -S-S-) is the common form of sulfur in cells but a few molecules of oxidized sulfur may be found in the form of sulfate esters ( $\text{C-O-SO}_3^-$ ) or sulfonates ( $\text{C-SO}_3^-$ ). A special physiological group of prokaryotes use sulfate as the final electron acceptor in respiration, and this process, resulting in the formation of  $\text{H}_2\text{S}$ , is termed *dissimilatory sulfate reduction*.

### 10.6.2 Inorganic Sulfur Metabolism

A unique physiological group of anaerobic bacteria can obtain energy from the reduction of sulfate to sulfide. Anaerobic sediments and mud often have an odor of rotten eggs



**Figure 10.12.** Microbial interactions with the sulfur cycle. Reactions associated with reduction are indicated by solid lines; with oxidation, by broken lines; and where the oxidation state of selenium does not change, by a dotted line. The following microorganisms are associated with these reactions: (1) phototrophic green and purple sulfur bacteria; (2) anaerobic bacteria and archaea; (3) phototrophic green and purple sulfur bacteria; (4) dismutation where four sulfite molecules produce three sulfate molecules and one sulfide, *Desulfovibrio sulfodismutans*; (5) dissimilatory reduction by *Desulfovibrio*, *Desulfotomaculum*, and other sulfate-reducing bacteria; (6) metabolism by heterotrophic bacteria; (7) assimilatory reduction, most microorganisms.

and this is attributed to the high levels of hydrogen sulfide released by sulfate-reducing bacteria. With sulfate present in marine and limnic environments at 28 mM, marine sediments will have appreciable quantities of sulfide produced from dissimilatory sulfate reduction activities.

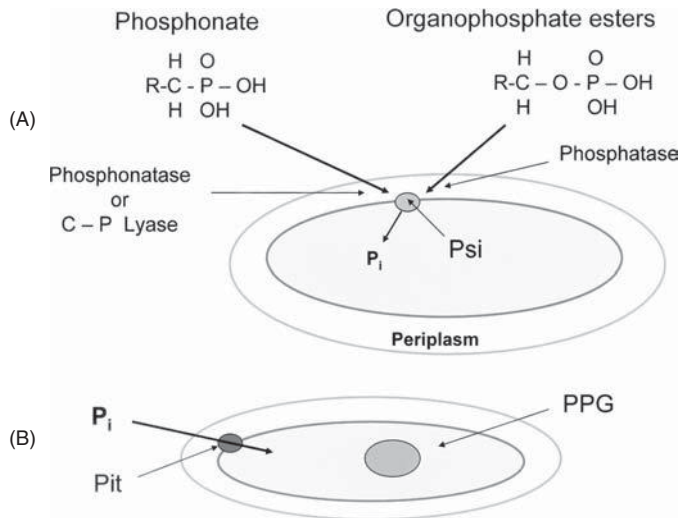
Various microorganisms can mineralize sulfur from organic sulfur compounds with the release of  $\text{H}_2\text{S}$ . Aquatic environments near neutrality will have considerable levels of reduced sulfur in the form of  $\text{HS}^-$ , and this ion can be oxidized to elemental sulfur ( $\text{S}^0$ ) by chemolithotrophic bacteria or anaerobic photosynthetic sulfur bacteria. Some sulfur bacteria will use  $\text{S}^0$  as an electron acceptor for growth with the regeneration of hydrogen sulfide. Chemolithotrophic bacteria will oxidize  $\text{S}^0$  to thiosulfate, sulfite, or sulfate. Many different genera of microorganisms will oxidize thiosulfate or sulfite to sulfate; however, there are relatively few bacteria that function as dissimilatory sulfate reducers.

## 10.7 PHOSPHORUS CYCLING

Phosphorus is essential for microbial systems because it is a required component for sugar phosphates, RNA, DNA and high energy molecules. Because many of the inorganic salts of phosphate have a low solubility in aquatic environments, phosphorus is commonly a limiting nutrient in natural environments, and bacteria have adjusted to overcome this limitation. The principal mechanism for bacterial acquisition of phosphorus is to use uptake transport systems for inorganic phosphate. Since iron and calcium form insoluble phosphate minerals, bacteria will solubilize phosphate by the production of acidic end products of metabolism. Organic phosphorous compounds in the form of phosphate esters are a product of biological material decaying, and phosphatase enzymes will release inorganic phosphate. There are two major groups of phosphatase enzymes: acid phosphatases and alkaline phosphatases. This classification of phosphates reflects the pH for optimum activity, and both types can use a variety of organic compounds with phosphate esters as substrates. Generally, organisms in aquatic or soil environments will use alkaline phosphatases, while intracellular organisms growing inside vacuoles of host cells use acidic phosphatase.

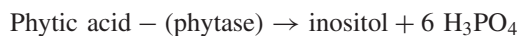
Additionally, organic molecules containing phosphorus may have a direct C–P bond; these molecules represent the phosphonates. Phosphonates are relatively common in nature, and inorganic phosphate may be released following the action of either a phosphonase or a C–P lyase (Wanner 1994). Bacterial utilization of phosphate and phosphonate are summarized in the reactions shown in Figure 10.13. Since inorganic phosphate may be limiting in the environment, many bacteria will store phosphate as a dense granule inside the cell. During periods of adequate levels of phosphate, it accumulates inside the cell as a polyphosphate granule, and when extracellular phosphate becomes limiting the polyphosphate reserve is utilized. For cultivation of microorganisms in the laboratory, phosphate is commonly used as a buffer; however, in nature carbonate, and not phosphate, functions to maintain the pH within the tolerance levels for growth.

There is a sensitive regulatory process that controls the production of different enzymes for phosphate utilization, and this is an important feature for bacterial persistence in the environment. When inorganic phosphate is available in adequate levels to support growth of bacteria, inorganic phosphate is transported into the cell by a low-affinity transport system with the repression of acid or alkaline phosphatase and phosphonase or a lyase. If inorganic phosphate is limiting, bacteria will produce appropriate enzymes for release of inorganic phosphate from phosphate esters or from phosphonates.



**Figure 10.13.** Reactions summarizing phosphorus interactions with bacteria: (A) utilization of phosphonates and organophosphates as a substrate. The enzymes associated with release of phosphate from phosphonate would be either a lyase or a phosphonatase located between the outer membrane and the plasma membrane as indicated by the arrow. Phosphatase activity for release of phosphate from organophosphates would be functioning in the periplasmic region. Uptake of phosphate may be by the high-affinity Psi (Phosphate starvation-inducible) system. (B) Uptake of inorganic phosphate ( $\text{P}_i$ ) by a low-affinity Pit (inorganic phosphate transporter) (PPG = polyphosphate granule in cytoplasm of cell).

Phytic acid is a phosphate storage compound found in plant seeds and is an excellent source of phosphate. It is inositol hexaphosphate, which is a hexose with six phosphate residues esterified on the six-carbon sugar. Enzymatic hydrolysis of phytic acid occurs by phytase according to the following reaction:



Phytase is an extracellular enzyme produced by several strains of bacteria and fungi found in soil environments as well as in stomachs of ruminants (cows, sheep, etc.). Monogastric animals such as humans, pigs, and chickens do not have the appropriate microbial flora to produce phytase, so phytic acid is not decomposed in the animal but is released with the intestinal waste (Wodzinski and Ullan 1996). Phytic acid is readily metabolized by microorganisms in the soil or in aquatic environments.

## 10.8 IRON CYCLING

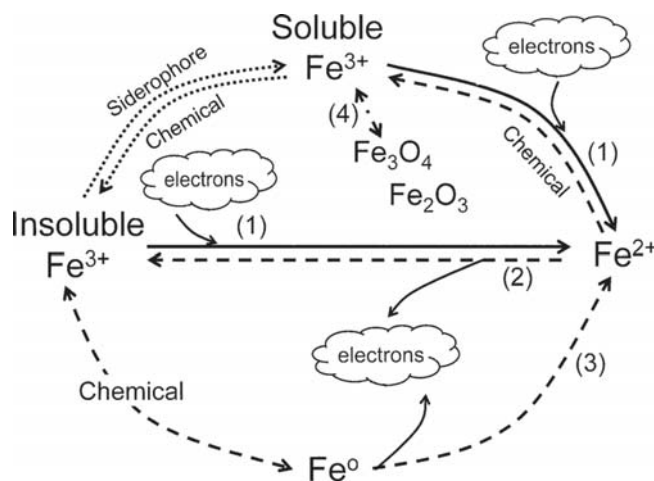
Most biological systems can catalyze redox reactions of iron since iron functions as  $\text{Fe}^{3+}/\text{Fe}^{2+}$  in cytochromes. Iron is also used by microbial systems for various other activities; these are summarized in Figure 10.14. In a few chemolithotrophic bacteria, iron is an important element for energy production. As indicated in Table 10.2, iron in the form

of  $\text{Fe}^{2+}$  can be used as an electron donor for the respiratory-coupled cytochrome system with the accumulation of  $\text{Fe}^{3+}$ . With some chemolithotrophic bacteria,  $\text{Fe}^{3+}$  can be an electron acceptor with electrons coming from the membrane-bound cytochrome system to produce  $\text{Fe}^{2+}$ . The chemolithotrophic bacteria that use  $\text{Fe}^{3+}$  as the electron donor and molecular oxygen as the electron acceptor would require a system to acquire  $\text{Fe}^{3+}$  for cellular metabolism. Extracellular release of riboflavin from iron-oxidizing bacteria had been reported (Marsili et al. 2008), but the mechanism for riboflavin participation in iron uptake remains to be established.

### 10.8.1 Siderophores

Iron is the fourth most abundant element in Earth's crust; however, it is often a growth-limiting nutrient for microorganisms and plants, due to the low solubility of  $\text{Fe}^{3+}$  salts at neutral pH (Drechsel and Winkelmann 1997). Rarely is iron a limiting nutrient for anaerobic organisms because  $\text{Fe}^{2+}$  salts are highly soluble at pH levels near 7. The biological response to iron limitation by aerobic organisms is varied but generally involves increased mobilization of  $\text{Fe}^{3+}$  from the environment and transmembrane uptake of iron.

In plants there are two major strategies for iron uptake, with monocotyledons producing phytosiderophores that sequester  $\text{Fe}^{3+}$  from the soil, while dicotyledons expel protons to acidify the root zone and acquire iron following reduction of  $\text{Fe}^{3+}$  to  $\text{Fe}^{2+}$  at the root surface (Römheld 1987). When iron is limiting, aerobic bacteria and fungi produce siderophores to solubilize  $\text{Fe}^{3+}$  from the environment and transport the siderophore- $\text{Fe}^{3+}$  complex into the cell (Drechsel and Winkelmann 1997). It appears that each microbial

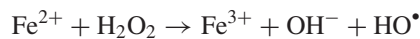


**Figure 10.14.** Iron cycle with microbial interactions. Solid line indicates reduction, broken line indicates oxidation, and dotted line indicates no change in oxidation state. Typical organism associated with reactions: (1) anaerobic activity of *Geobacter* and *Shewanella*; (2) aerobic and neutral pH activity is due to *Arthrobacter*, *Gallionella*, and *Pedomicrobium*, while aerobic and acidic is due to *Sulfolobus*, *Leptospirillum*, and *Thiobacillus ferrooxidans*; (3) biocorrosion due to *Desulfovibrio*; (4)  $\text{Fe}_3\text{O}_4$  in magnetosomes, *Aquaspirillum magnetotactium*, and  $\text{Fe}_2\text{O}_3$  is ferritin which is found in most aerobic bacteria.

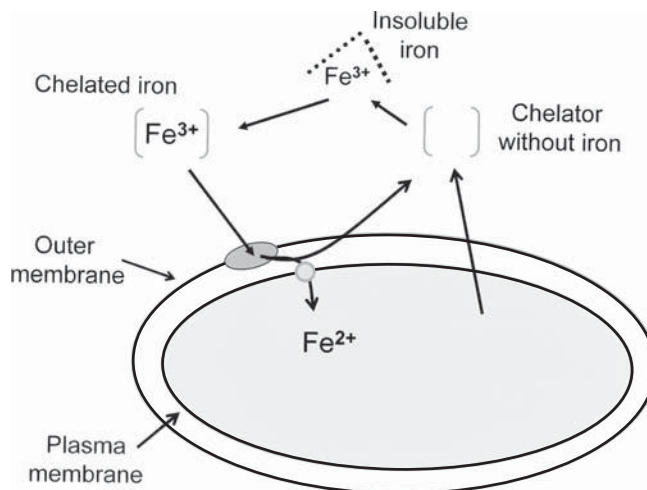
species has its own unique  $\text{Fe}^{3+}$ -chelating molecular structures, and over 500 different microbial siderophores have been identified. Siderophores are not only essential for bacteria to grow in soil and water but also considered crucial virulence factors for bacterial pathogens. In the terrestrial environment,  $\text{Fe}^{3+}$  is present in minerals as insoluble oxides, phosphates, carbonates, and hydroxides while in animals  $\text{Fe}^{3+}$  is bound to ferritin, transferrin, or lactoferrin. While each aerobic microorganism has its own specific siderophore-mediated system for  $\text{Fe}^{3+}$  uptake, a few bacteria have acquired multiple systems for the uptake of several different types of siderophores as a result of lateral gene transfer. A model indicating siderophore acquisition of  $\text{Fe}^{3+}$  is presented in Figure 10.15.

### 10.8.2 Ferritin and Magnetosomes

Acquisition of iron by microorganisms must be tightly regulated to prevent overaccumulation of soluble iron in the cytoplasm. As  $\text{Fe}^{3+}$  is transported into the aerobic bacterial cell, it is reduced by NADH or NADPH to  $\text{Fe}^{2+}$  at the plasma membrane. Free intracellular  $\text{Fe}^{2+}$  may be detrimental because it will react with the low levels of  $\text{H}_2\text{O}_2$  produced in the cell by various reactions. Toxicity due to hydroxyl free radical ( $\text{HO}\cdot$ ) can result in the cytoplasm according to the following reaction:



Thus, cells prevent accumulation of free intracellular  $\text{Fe}^{2+}$  by binding ionic iron into ferritin. In bacteria, as in plants and animals, the iron-binding ferritin molecule consists of protein plus several thousand atoms of ionic iron. Iron can be utilized from ferritin when iron becomes limiting in the environment, but of greater importance is the sequestering of intracellular ionic iron.

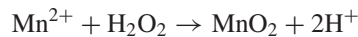


**Figure 10.15.** Generalized uptake of  $\text{Fe}^{3+}$  by bacteria using siderophores as chelating agents. The siderophore is released from the bacterial cell into the environment and, due to the high binding affinity of the chelator for  $\text{Fe}^{3+}$ , iron is sequestered by the siderophore. The chelator with iron is recognized by a specific protein in the outer membrane, and reduction of  $\text{Fe}^{3+}$  to  $\text{Fe}^{2+}$  occurs at the plasma membrane.



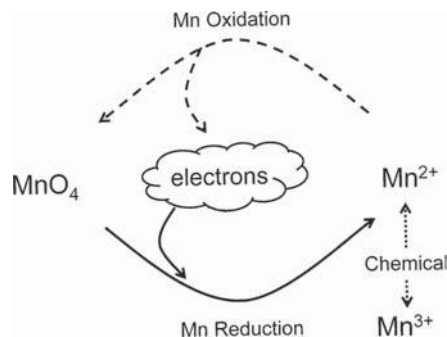
## 10.9 CYCLING OF MANGANESE AND SELENIUM

Some chemolithotrophic bacteria can obtain energy from the reduction of  $\text{Mn}^{4+}$  to  $\text{Mn}^{2+}$  or from oxidation of  $\text{Mn}^{2+}$  to  $\text{Mn}^{4+}$  (Figure 10.16) (Barton 2005). The oxidation of manganese by bacteria is associated with three different activities: (1) oxidation of soluble manganese, (2) oxidation of immobilized manganese, and (3) production of hydrogen peroxide resulting in the oxidation of manganese. Oxidation of soluble  $\text{Mn}^{2+}$  has been attributed to enzymes produced by *Leptothrix*, *Pseudomonas*, *Citrobacter*, *Bacillus*, *Arthrobacter*, and *Hypomicrobium* (Tebo et al. 2005). If electrons from the oxidation of soluble manganese are shuttled to molecular oxygen, cells can grow because sufficient energy is released (see Table 10.2). A second mechanism for manganese oxidation occurs if manganese is bound onto clay or insoluble manganese oxides. The enzyme associated with this activity is considered to be at the surface of the cell and bacteria that may be associated with this activity, including *Vibrio*, *Arthrobacter*, and *Oceanospirillum*:



Manganese oxides may consist of manganese dioxide  $\text{MnO}_2$ , hausmannite ( $\text{Mn}_3\text{O}_4$ ), or manganite ( $\text{MnOOH}$ ), and microbial oxidation occurs more rapidly with amorphous manganese oxides than with crystalline forms. While several genera of bacteria are known to reduce manganese, the systems of *Geobacter* and *Shewanella* are highly characterized. Several additional reactions can account for reduction of manganese; these may be attributed to microbial activity. Microorganisms may produce formic acid,  $\text{H}_2\text{S}$ , or  $\text{Fe}^{2+}$ , and these chemicals will react with  $\text{MnO}_2$  to produce  $\text{Mn}^{2+}$ . This underscores the potential for interactions between biogeochemical cycles.

As a result of bacteria-oxidizing manganese, there are two important environmental observations: the formation of desert varnish (Kuhlman 2006) and manganese nodules (Hlawatsch et al. 2002) on the ocean floor (see Figure 10.17). The manganese nodules may reach a diameter of over 25 cm, and because they frequently contain oxides of iron as well as manganese, they are referred to as *ferromanganese nodules*. The formation of manganese nodules from marine waters is attributed to manganese-oxidizing bacteria and bacteria secreting a carbohydrate matrix to immobilize the manganese.



**Figure 10.16.** Microbial interactions with manganese. Oxidation is attributed to *Arthrobacter*, *Leptothrix discophora*, and *Pedomicrobium*. Reduction is attributed to *Geobacter* and *Shewanella*. Chemical oxidation to +3 is associated with hydrogen peroxide release by wood-rotting fungi (see Chapter 11).



**Figure 10.17.** Manganese nodule collected from the Pacific Ocean. The nodule is approximately 12 in. in diameter. (Source: Geology Museum, University of Nanning, China. Photograph provided by Larry Barton.) See insert for color representation.

### *Microbial Spotlight*

#### **BRAD TEBO**



Brad Tebo, now at the Oregon Health and Sciences University, drew his inspiration from Ken Neelson, his undergraduate and graduate advisor. “Ken Neelson has been a great inspiration in my career and has been the biggest influence on where I am today. As an undergraduate I was instilled with a love of science and a desire to understand the mechanisms of how microbes do things.”

Brad became involved in Ken's research on manganese nodules, when the postdoc on the project was unable to participate in the cruises to collect samples:

The idea here was that in Saanich Inlet [Vancouver Island], which is a seasonally anoxic fjord, you have this oxic–anoxic interface and the geochemists were modeling the distribution and speciation of manganese across that interface estimated the residence time of manganese to be really short and they hypothesized that it was due to microbial activities. Ken enlisted me to go on this cruise for him and once I went to sea, it was all over. I just loved it. It was just like doing research on a research vessel in beautiful parts of the world. I spent the rest of my career working on manganese and my thesis was to that question: Do microbes catalyze manganese oxidation in the environment—are they responsible for most of it?

One of the big surprises of their work came from the electron microscopy on the isolates, in particular the spores of *Bacillus*:

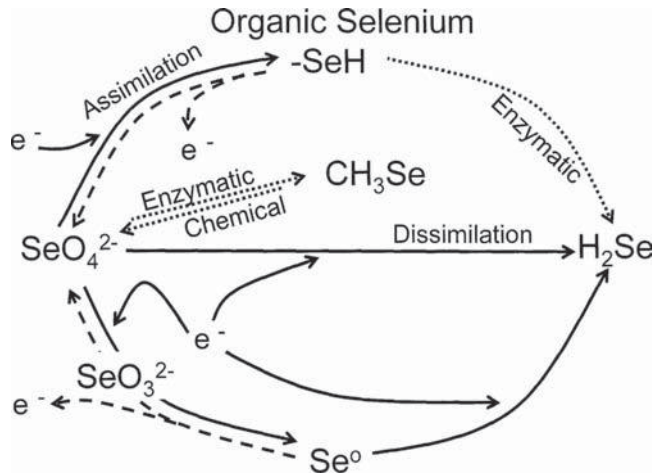
[The] spores were a real surprise because no one expected spores to be active in catalyzing a biogeochemical process. Spores are thought to be dormant and completely inert, and resting stages, but they clearly have an active enzyme that can catalyze reactions without involved metabolic energy. So it may not be your classic metabolic enzyme, but it is an enzyme because it greatly accelerates the oxidation of manganese. That's been hard for people to grasp. Over the years, people have said, "How could they be doing anything—they're spores; they're dormant," but clearly they have a surface enzyme that's important for oxidizing manganese and that's been a point that people have found it hard to accept—that these things are active in the environment.

More recently, Brad has puzzled over

how much inorganic energy do microbes really get from the Earth's crust. Basalt has lots of reduced metals, iron and manganese. We know that beneath the ocean, basalt makes up a major fraction of the crust and there's all this interest in the deep biosphere. It's an overarching question that is very important to address. Related to that is: do bacteria get energy from manganese oxidation, which we still don't know. It's been hypothesized, I tend to believe it, but we haven't been able to prove it.

A lifetime of questions have flowed from Brad Tebo's early training with Ken Nealson.

In terms of chemistry, selenium is similar to sulfur, with oxidation states ranging from  $-2$  to  $+6$  (see Figure 10.18). Selenium is required by microorganisms at relatively low levels for the formation of selenomethionine ( $\text{Se}^{2-}$ ), where selenium replaces sulfur in methionine. Several dehydrogenases require selenomethionine for enzymatic activity. In nature selenium is commonly found in aquatic systems as selenate ( $\text{SO}_4^{2-}$ ) or selenite ( $\text{SeO}_3^{2-}$ ), and bacteria have specific uptake transport systems for these two selenium



**Figure 10.18.** Global selenium cycle with microbial interactions. Solid lines indicate reduction; dashed lines, oxidation; dotted lines, no change in oxidation state of Se. Microorganisms of various genera are associated with the reactions shown in the diagram.

anions. At elevated levels, selenium is toxic to cells, and many environmental bacteria will reduce selenite to either elemental selenium ( $\text{Se}^0$ ) or methylselenide ( $\text{Se}^{2-}$ ) (Oremland et al. 2004). Thus, microbial activities contribute to the global cycling of selenium.

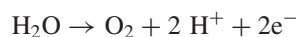
## 10.10 CYCLING OF HYDROGEN

Although little consideration is given to an official hydrogen cycle, the role of hydrogen in microbial systems is undisputed, and for this reason there is merit in discussing the cycling of hydrogen in the microbial world. The principal reservoir for hydrogen is water with ionization of water, yielding protons plus a hydroxyl ion:



Near neutrality there is little ionization with few protons; however, if those protons are used in reactions, there is a continuous shift in equilibrium of the reaction to promote continuous ionization. Protons are extremely important in bacterial metabolism because respiratory processes pump protons out of the cell across the plasma membrane, see discussion of Electron Transport in Section 3.91. A separation of protons and hydroxyl ions across the plasma contributes to the charge that may vary from  $-100$  to  $-250$  mV. Proton movement across the membrane of bacteria is important for ATP synthesis, flagellar movement, nutrient uptake, and solute export.

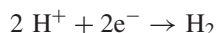
Water is the electron donor in aerobic photosynthesis, and as indicated in the following reaction, protons are released:



Through appropriate hydrogen carriers, these protons are transferred to  $\text{CO}_2$  in the formation of carbohydrates. As various organic compounds are produced from carbohydrates, hydrogen atoms are a part of the building structures of cells. When cells use sugars for

energy with the release of CO<sub>2</sub>, hydrogen is released as protons, and these protons unite with O<sub>2</sub> to produce water. This cycling of hydrogen from water to carbohydrates and back to water is indicated in Figures 10.5 and 10.6.

There is another microbial activity involving hydrogen cycling, and it is associated with hydrogenase. Anaerobic heterotrophic bacteria will produce a variety of end products of fermentation, and H<sub>2</sub> is one of these. The formation of H<sub>2</sub> is a highly efficient means for bacteria to release electrons, and this reaction is catalyzed by hydrogenase:



Hydrogen gas could be released from the fermentation mixture as bubbles; however, many anaerobic bacteria can use hydrogen as an electron donor to energize growth. This uptake of hydrogen is also catalyzed by hydrogenase to produce the following reaction:



With the same enzyme involved in two different activities, the direction of the hydrogenase reaction will be regulated by thermodynamics of the reaction concerned with the release or consumption of electrons.

To underscore the role that hydrogen plays in microbial energetics, there are two separate reactions involving anaerobic systems. There is the interspecies H<sub>2</sub> transfer that occurs between a producer of H<sub>2</sub> and a consumer of H<sub>2</sub>. An example of partners in hydrogen syntrophism would be *Syntrophomonas wolfei*, a H<sub>2</sub> producer, and a methanogen, a H<sub>2</sub> consumer (see Section 6.3.7). In this microbial partnership, consumption of H<sub>2</sub> by a methanogen enables *S. wolfei* to grow from fermentation of crotonic acid even though the thermodynamics of this reaction is unfavorable. Hydrogen cycling has been proposed to function in certain strains of sulfate-reducing bacteria where protons from the cytoplasm are converted to H<sub>2</sub> in the periplasm and membrane hydrogenase direct protons to the cytoplasm (Odom and Peck 1981). The hydrogen cycling in certain *Desulfovibrio* would benefit the bacterium by providing energy to the cell. There is also the production of H<sub>2</sub> by some nitrogen-fixing bacteria in an apparent release of excessive reducing activity.

## 10.11 TRANSFORMATION OF MERCURY

One of the most toxic metals is mercury, and microorganisms have unique processes that enable cells to grow in mercury-contaminated environments. As shown in Figure 10.19, mercury is moved through the biosphere, and some of these transformations are attributed to microorganisms. Aerobic bacteria, anaerobic bacteria, and a few fungi convert Hg<sup>2+</sup> to methyl mercury or dimethyl mercury. In aquatic environments, the concentrations of methyl mercury and Hg<sup>2+</sup> are amplified as they move through the food chain, with concentration of mercury in fish exceeding safe limits of humans. Both methyl mercury and dimethyl mercury may be released from the immediate environment into the atmosphere because of the high volatility of these compounds. Various Gram-positive and Gram-negative bacteria are capable of reducing Hg<sup>2+</sup> to elemental mercury (Hg<sup>0</sup>) using the *mer* operon (Silver and Misra 1988), and this genetic system is shown in Figure 10.20. Mercury metal (Hg<sup>0</sup>) is unusual because it is volatile at room temperature. Solar-mediated activities in the atmosphere are responsible for oxidization of Hg<sup>0</sup> to Hg<sup>2+</sup> and conversion

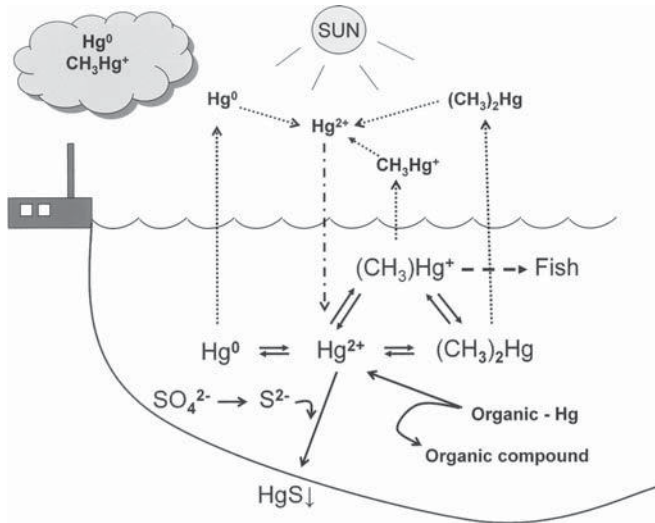


Figure 10.19. The role of microorganisms in global cycling of mercury.

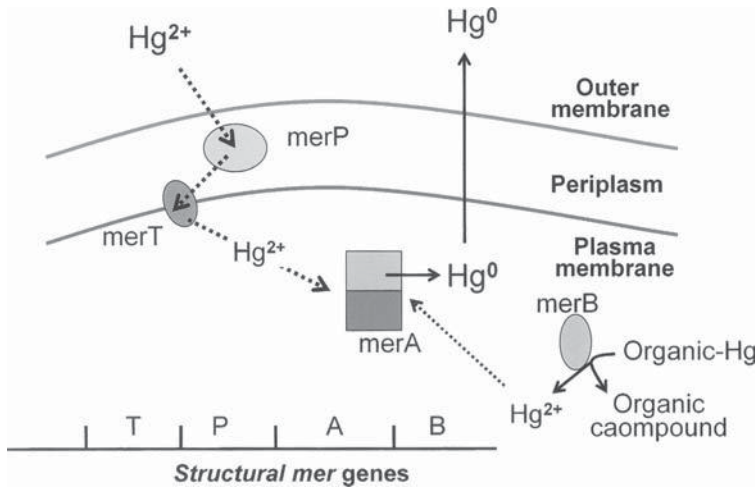


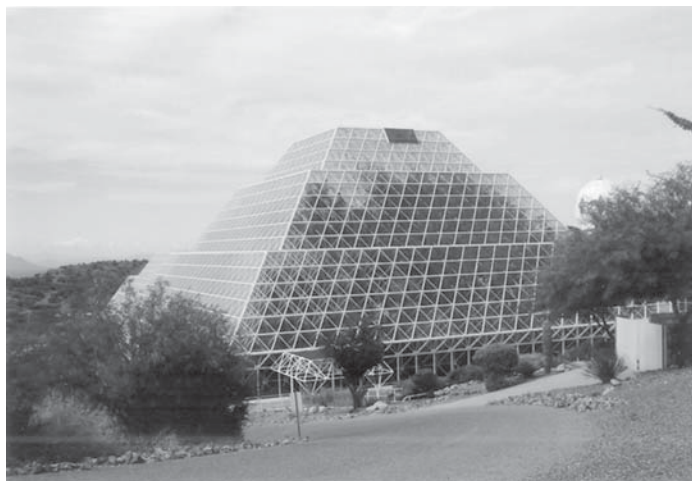
Figure 10.20. Cellular detoxification by the *mer* operon.

of methylated forms of mercury to  $Hg^{2+}$ . In addition to mercury entering the atmosphere from microbial activity, over 50,000 tons of  $Hg^0$  and methyl mercury are released from coal-burning factories. The *mer* operon also encodes a mercury lyase that releases  $Hg^{2+}$  from organic mercury compounds.

### 10.12 CLOSED SYSTEMS

It is difficult to follow microbial cycling activity in nature because it is an open system where atmospheric gases cannot be controlled. More recently, there has been some interest





**Figure 10.21.** Biosphere 2 near Tucson, Arizona (photograph by Larry Barton).

in following nutrient cycling in a closed system using Biosphere 2 (Figure 10.21). Rates of  $\text{CO}_2$  turnover by terrestrial microbial systems are being measured under controlled environments in Biosphere 2. Additionally, gas exchange rates can be carefully evaluated in rainforest and desert environments.

### 10.13 SUMMARY

Microorganisms and especially bacteria are opportunists that exploit reactions involving electron flow to maintain a charge on membranes and to produce ATP by chemiosmosis-driven oxidative phosphorylation. Often the organisms target a single electron transfer reaction and in terms of metabolism are specialists and frequently function without heterotrophic metabolic capabilities. For example, acidithiobacilli have adapted to growth on aerobic oxidation of elemental sulfur to sulfate with carbon dioxide as the carbon source and to growth at pH levels of  $\leq 2$ . If the environment does not have adequate levels of usable nitrogen compounds, many bacteria can produce ammonia from the reduction of  $\text{N}_2$ . Energy coupling to electron flow by these specialists is paramount because ATP is needed not only for biosynthesis of proteins, nucleic acids, and complex polysaccharides but also for utilization of  $\text{CO}_2$ ,  $\text{N}_2$ , and inorganic sulfate. Thus, each elemental cycle should be considered as a combination of individual steps where each step is attributed to a specific bacterial type.

In the environment there is an unusual process of nutrient sharing where the end product of one bacterial type may serve as the substrate for another bacterial specialist. If one assembles these end products and substrates of the various growth-supporting elements, cycles are established. If an element is initially oxidized or reduced by a bacterial type but another bacterial type grows by reversing the redox activity, a minielement cycle is established. This cycling of elements is an expression of energy conservation as well as conservation of nutrients. While some activities may lead to end product accumulation, as is the case of aerobic photosynthetic production of  $\text{O}_2$  from water to establish an

oxygen-containing atmosphere on Earth, currently various mechanisms interact to stabilize the nutrient cycles. The efficiency seen in elemental cycling is also observed in various metabolic processes that involve cycles such as the tricarboxylic acid (Kreb's) cycle. An important lesson is that nature recycles.

### 10.14 DELVING DEEPER: CRITICAL THINKING QUESTIONS

1. Global C, N, and S cycles are collective activities of microorganisms. Are there regions or sites where C, N, or S compounds would accumulate and not be cycled? What would be some reasons why these biological compounds containing C, S, or N may accumulate?
2. What is the contribution of bacteria to greenhouse gasses?
3. Describe how a bacterial community could interact with several different nutrient cycles.
4. What would be the impact of chemolithotrophic bacteria on the sulfur cycle? What activity would be characteristic of heterotrophic bacteria in the sulfur cycle? On a global cycle perspective, can you identify which is more important?
5. In terms of the carbon–nitrogen cycle, characterize the activities that would likely occur at the surface of a lake. What activities would be occurring in the mud at the bottom of the lake?
6. With respect to iron nutrition and the iron cycle, what is the role of iron as relates to bacterial growth in humans? What is the role of iron with respect to bacterial nitrogen fixation of nitrogen in legumes growing in alkaline soil?
7. What are some reasons that could contribute to phosphorus being growth-limiting for microorganism in the environment?
8. Elements such as Fe, Mn, and Se may serve as electron donors for some bacteria and as electron acceptors by other bacteria. Identify the steps for these activities in their respective cycles.

### BIBLIOGRAPHIC MATERIAL

#### Further Reading

Nealson KH (1997), Sediment bacteria: Who'se there, what are they doing, and what's new? *Annu. Rev. Earth Planet. Sci.* **25**:403–434.

McElroy M (1983), *Global Change: A Biogeochemical Perspective*, JPL Publication 83–51, Pasadena, CA: Jet Propulsion Laboratory.

Morel FMM, Price NM (2003), The biogeochemical cycles of trace metals in oceans, *Science* **300**:944–947.

Post WM, Peng T-H, Emanuel WR, King AW, Dale VH, DeAngelis DL (1990), The global carbon cycle, *Am. Sci.* **78**:310–326.

Sinsabaugh RL, Hill BH, Fallstad Shah JJ (2009), Ecoenzymatic stoichiometry of microbial organic nutrient acquisition in soil and sediment, *Nature* **462**:795–798.

Yaiz L, Zeiger E (1998), *Plant Physiology*, Sunderland, MA: Sinauer Associates, Publishers.

Vernadsky VI (2007), *Essays on Geochemistry and the Biosphere* (transl. by Olga Barash), Santa Fe, NM: Synergetic Press.

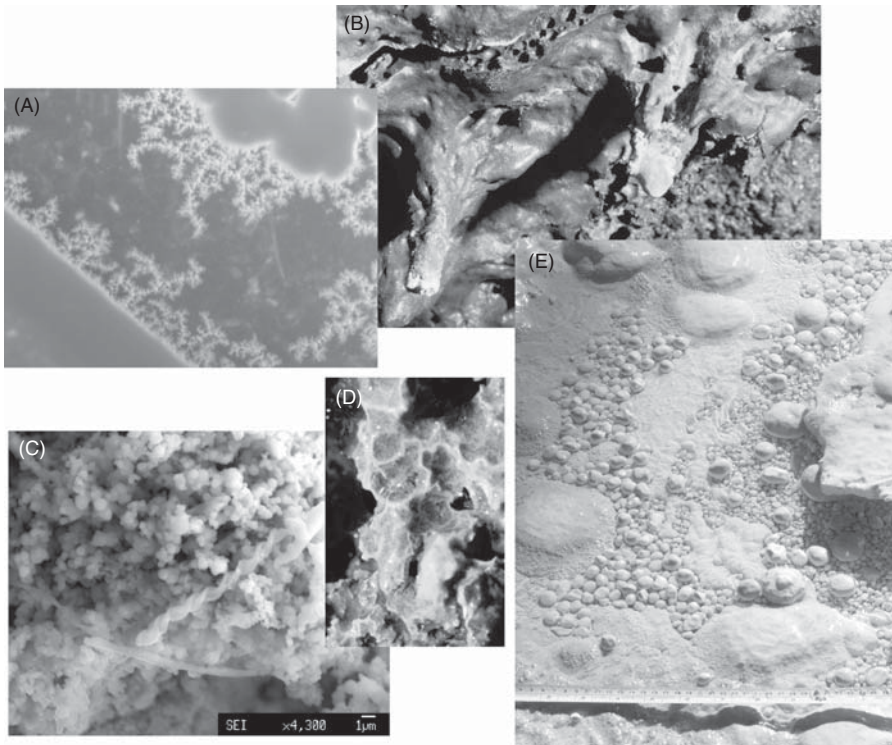
### Cited References

- Barton LL (2005), *Structural and Functional Relationships in Prokaryotes*, New York: Springer.
- Barton LL, Goulhen F, Bruschi M, Woodards NA, Plunkett RM, Rietmeijer FJM (2007), The bacterial metallome: Composition and stability with respect to the anaerobic bacterium *Desulfovibrio desulfuricans*, *Biomaterials* **20**:291–302.
- Buchanan BB, Gruissem W, Jones RL (2000), *Biochemistry and Molecular Biology of Plants*, Rockville, MD: American Society of Plant Physiologists.
- Drechsel H, Winkelmann G (1997), Iron chelation and siderophores, in Winkelmann G, Carrano CJ, eds., *Transition Metals in Microbial Metabolism*, Amsterdam: Harwood Academic Publishers, pp. 1–50.
- Hlawatsch S, Neumann T, Van Den Berg CMG, Kersten M, Harff J, Suess E (2002), Fast-growing, shallow-water ferro-manganese nodules from the western Baltic Sea origin and modes of trace element incorporation, *Marine Geol.* **182**:373–387
- Holmen K (1992), The global carbon cycle, in Butcher SS, Charlson RJ, Orians GH, Wolfe GV, eds., *Global Biogeochemical Cycles*, New York: Academic Press.
- Kuhlman KR, Fusco WG, La Duc MT, Allenbach LB, Ball BL, Kuhlman GM, Anderson RC, Erickson IK, Stuecker T, Benardin J, Strap JL, Crawford RL (2006), Diversity of microorganisms within rock varnish in the Whipple Mountains, California, *Appl. Environ. Microbiol.* **72**:1708–1715.
- Marsili E, Baron DB, Shikhare ID, Coursolle D, Gralnick JA, Bond DR (2008), *Shewanella* secretes flavins that mediate extracellular electron transfer, *Proc. Natl. Acad. Sci. (USA)* **105**:3968–3973.
- Milkov AV (2004), Global estimates of hydrate-bound gas in sediments: How much is really out there? *Earth Sci. Rev.* **66**:183–197.
- Odom JM, Peck HD Jr (1981), Hydrogen cycling as a general mechanism for energy coupling in the sulphate-reducing bacteria, *Desulfovibrio* sp., *FEMS Microbiol. Lett.* **12**:47–50.
- Oremland RS, Herbel MJ, Switzer Blum J, Sean Langley S, Beveridge TJ, Ajayan PM, Sutto T, Ellis AV, Curran S (2004), Structural and spectral features of selenium nanospheres produced by Se-respiring bacteria, *Appl. Environ. Microbiol.* **70**:52–60.
- Römheld V (1987), Existence of two different strategies for the acquisition of iron in higher plants, in Winkelmann G, van der Helm D, Neilands JB, eds., *Iron Transport in Microbes, Plants and Animals*, Weinheim: VCH Publishers, pp. 353–374.
- Schlesinger W (1991), *Biogeochemistry: An Analysis of Global Change*, New York: Academic Press.
- Silver S, Misra TK (1988), Plasmid-mediated heavy metal resistances, *Annu. Rev. Microbiol.* **42**:717–743.
- Stanier TS, Ingraham JL, Wjeelis ML, Painter PR (1986), *The Microbial World*, 5th ed., Englewood, NJ: Prentice-Hall.
- Tebo BM, Johnson HA, McCarthy JK, Templeton AS (2005), Geomicrobiology of manganese(II) oxidation, *Trends Microbiol.* **13**:421–428.
- Wanner BL (1994), Phosphate-regulated genes for the utilization of phosphonates in members of the family *Enterobacteriaceae*, in Torriani-Gorini S, Yagi E, Silver, S, eds., *Phosphate in Microorganisms*, Washington DC: ASM Press, pp. 215–221.
- Wodzinski RJ, Ullan AH (1996), Phytase, *Adv. Appl. Microbiol.* **42**:263–303.

# MICROBES AT WORK IN NATURE: BIOMINERALIZATION AND MICROBIAL WEATHERING

## 11.1 CENTRAL THEMES

- The ability of microorganisms to form mineral phases can be active or passive.
- Microorganisms precipitate some minerals (Figure 11.1), while aiding in the dissolution of others.
- Several characteristics of microbial cells, such as negatively charged functional groups on cell surfaces and the production of extracellular polymeric substances, contribute to the binding of metal ions, and sometimes to the precipitation of minerals.
- Reduction–oxidation reactions (redox) play key roles in geomicrobiological interactions.
- The ability of microorganisms to affect the solubility of minerals and their ability to carry out complex redox reactions are key components of their roles in ore formation and recovery, and in enhanced petroleum recovery.
- Microbially influenced corrosion can have disastrous effects on metallic surfaces, such as water pipes or ship hulls.
- Microorganisms associated with oil and gas deposits can produce hydrogen sulfide that is oxidized to sulfuric acid biologically and abiotically, which carves out enormous caverns beneath Earth's surface.



**Figure 11.1.** Biomineralization in various habitats: (A) calcite precipitating microorganisms cultured from Fort Stanton Cave, NM; (B) blue-green mineral deposits in a lava tube in Hawai'i contain a variety of microorganisms; (C) *Gallionella*-like bacteria in the deposits from a well; (D) yellow-gold deposits from the walls of Thurston Lava tube in Hawai'i contain a wealth of microorganisms; (E) cave pearls in a mine in Illinois show microscopic evidence of microorganisms. [Images courtesy of Ian McMillan (A), Kenneth Ingham (B,D,E), and Kevin McVey (C).] See insert for color representation.

- Silica can be precipitated actively or passively to form the elaborate structures of diatoms, or the spicular geysers associated with hot springs and geysers.
- Active and passive biomineralization produce magnetite, an important process in biogeochemical cycling of iron and an important mineral in magnetotactic bacteria.
- A vigorous debate is in progress concerning the role of microorganisms in the formation of rock varnish, a patina that coats rocks.
- Microorganisms play complex roles in the formation of various carbonates.
- Stromatolites, which provide ancient evidence of microbial–rock interactions as well as modern models of interactions, reveal microbial processes involved in rock formation.

## 11.2 INTRODUCTION

Geologists tend to attribute observable mineral changes to abiotic process, while biologists try to explain everything in terms of biotic mechanisms (Barton et al. 2001); in

reality, the actual mechanisms are often a combination of abiotic and biotic. Geomicrobiology recognizes that microorganisms are important active and passive promoters of redox reactions that can influence geologic formation (Ehrlich 2002), or *biomineralization*, the process by which microorganisms form mineral phases. Geomicrobiological processes take place across large spatial and temporal scales, from minutes to eons and from microenvironments to global scales. However, the role of microorganisms in most processes is often unquantified and unseen because of the very small sizes of the participants. Microbes are crucial to nutrient cycling, able to discriminate among the stable isotopes of H, C, O, N, and S, resulting in fractionation and enrichment of lighter isotopes that we use as a marker of biological activity. Microbial activity also plays an important role in industry, having roles in the creation of the extensive iron mineral deposits, sulfur domes, marine manganese nodules, and potentially the accumulation of uranium and gold (Ehrlich 2002).

### ***Microbial Spotlight***

**T. C. ONSTOTT**



Image of T. C. Onstott at Kloof Mine 4 shaft, level 41, about 3.3 km down. —(Photograph courtesy of T. C. Onstott).

Sometimes strong need can change your scientific life and set you on the path to great discoveries! The need for funding in his early career prompted T. C. Onstott to attend a DOE (Department of Energy) meeting on the Triassic Basin, where he heard a lecture by Tommy Phelps about subsurface bacteria. This really caught his attention because “I had literally never seen or heard anything like that before—it was like they [the bacteria] were from another planet. I couldn’t believe that people were finding organisms in rocks and growing them up and then speculating that they had been trapped down there for hundreds



of millions of years." This led to an abrupt change in T. C.'s research focus, as he notes: "I became quite infatuated by this whole relationship between subsurface bacteria and geological history. And it was at that time I also realized that [there was a] relationship between life beneath the surface of Mars and subsurface bacteria," due to a paper that Penny Boston and Chris McKay published on the potential of lithotrophic subsurface ecosystems on Mars. T. C. had always had a strong interest in the potential for life on Mars:

but I never gave it enough thought to really consider the microorganisms, of which I knew nothing at the time; I didn't even know the difference between a prokaryote and a eukaryote; ... I thought 16S was some kind of isotope of sulfur or something; once I realized, it was a complete paradigm shift for me. And that has been the principle motivation for me all along. I've been very interested in the deepest continental life forms I can find just to try to find niches or ecosystems that have been isolated from photosynthesis for millions and millions of years and can still survive.

In pursuing these interests, T. C. discovered "a real surprise... We started discovering nematodes in a South African gold mine at about 1.5 km depth; and they appear to be grazing on biofilms in the fracture zones; they're reproducing asexually, and they survive on a minimal amount of oxygen." He and colleagues have discovered that multicellular organisms can penetrate deeply into the Earth and can survive and even metabolize at extremely low oxygen levels, a truly amazing discovery.

### 11.2.1 Passive versus Active Biomineralization

Biomineralization can occur passively or actively, in processes termed *biologically induced mineralization* (or precipitation) or *biologically controlled mineralization* (or precipitation), as first defined by Lowenstam (1981). Biologically induced mineralization (BIM) occurs as a result of the effects that organismal metabolic activities (e.g., oxidation of  $\text{Fe}^{2+}$ ) and byproducts (e.g.,  $\text{OH}^-$ ) have on the local physicochemical environment, favoring conditions that promote mineral production. The presence of negatively charged microbial cell surfaces can lead to nucleation and mineral precipitation. Negatively charged functional groups in the cell wall interact with cations (positively charged ions) in the surrounding aqueous environment, which can contribute to supersaturation in the local environment. BIM appears to be more important in anaerobic habitats or at the oxic–anoxic boundary and depends on environmental conditions such as pH,  $E_h$  (Hartree energy), and temperature. BIM processes are controlled by the same equilibrium principles that control abiological mineral precipitation and tend to produce amorphous or poorly crystalline minerals. Biologically controlled mineralization (BCM), on the other hand, represents the active role that microorganisms play in creation of biominerals from nucleation through mineral growth. Microorganisms move particular ions into organic matrices (or vesicles) that are positioned intracellularly or extracellularly to create states of mineral saturation. The ultrastructure of this vesicle or space controls the orientation, size, and morphology of the highly ordered crystals that are formed. We will examine examples of both passive and active biomineralization within this chapter.



### 11.3 CELL CHARACTERISTICS AND METAL BINDING

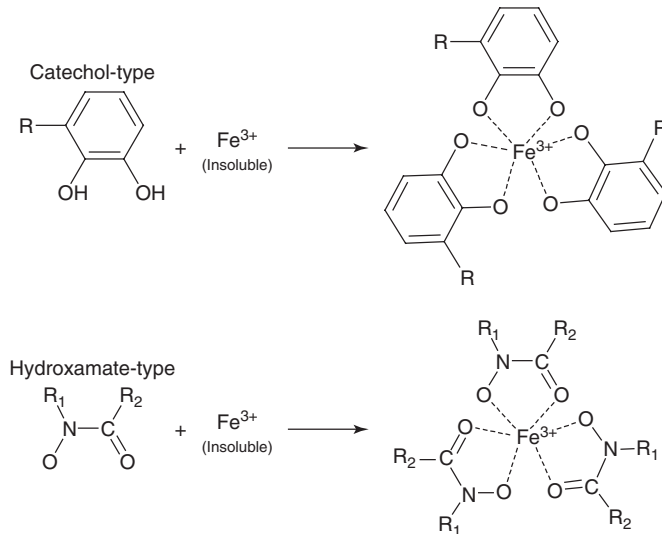
Bacterial cell walls can be Gram-positive, with thick peptidoglycan layers, or Gram-negative, with very thin peptidoglycan layers surrounding the cell. Additional layers on many bacteria include extracellular polymeric substances (EPSs), sheaths, and S layers, all of which can play important roles in microbe–mineral interactions. Extracellular polymeric substances (EPSs), also termed *extracellular polymers*, *glycocalyxes*, or *extracellular polysaccharides*, are produced within the cell, excreted to the exterior, and extremely hydrated. EPS layers are very diverse across microbial species and even within a species, varying in their saccharide and protein makeup. When highly structured, they may be called a *capsule*; when less structured, a *slime layer*. EPSs convey strong advantages, including (1) assistance in adhering to surfaces, (2) protection from environmental conditions, and (3) binding metals to the cell. Several important filamentous geomicrobiological species, such as *Leptothrix*, a manganese-oxidizing bacterium, sport sheaths, structures that enclose the bacterium in hollow tube-like structure. Sheaths are somewhat impermeable to large molecules, preventing some substances from reaching the cell that resides within. The charge of the sheath surface may differ from that of the cell wall, possibly affecting reactions with the environment. The third layer type, S layers, are widespread in bacteria and archaea, and function similarly to sheaths. Protein components are highly ordered and provide a barrier to larger molecules. Like sheaths, S layers can have a charge that differs from that of the wall beneath them, and in some instances, S layers can bind substantial metals, which are later shed with the S layer.

#### 11.3.1 Passive Metal Adsorption

An important aspect of metal adsorption to bacterial cell walls is the negative charge associated with cell walls. Functional groups in the cell wall (carboxyl, phosphate, hydroxyl, sulfhydryl, amino, and amide groups) provide a charge on the cell surface of bacteria when the functional groups are ionized. The negative charge associated with anionic functional groups can bind many metal cations. Factors that affect metal absorption include (1) the number of carboxyl groups, which are the most electronegative functional groups; (2) the amount of crosslinking between strands in the peptidoglycan; (3) the nature and number of secondary polymers; (4) Gram status (Gram-positive cell walls can bind more metals); and (5) the presence of EPS. Metal adsorption to cell surfaces is not restricted to bacteria and archaea. In eukaryotes, several examples of metal binding are found within the algae and fungi. Brown algae contain alginate with uronic acids whose carboxyl groups are key in metal adsorption. Chitin and chitosan functional groups in fungi are key to metal adsorption. While these metal adsorption processes are primarily passive, other more active processes are also employed by microorganisms.

#### 11.3.2 Active Metal Adsorption

Microorganisms possess the ability to change their organic functional groups in order to selectively adsorb metals. Some do this in order to obtain metals, such as iron, that are present in low amounts in the environment, but needed by cells for their growth and metabolic activities. Others make metal binding chelates that they excrete from their



**Figure 11.2.** The chemical structure of hydroxamate and catecholate siderophores.

cells in order to immobilize toxic metals that they want to remove from their vicinity. A particularly interesting group of the former is the siderophores.

Ferric iron (Fe(III) or Fe<sup>3+</sup>) is insoluble at pH levels near 7, but is needed by all microorganisms. To acquire the needed iron, bacteria and fungi secrete siderophores, which bind the Fe(III). The complex of Fe(III) and the siderophore is transported into the cell, where the Fe(III) is reduced to Fe(II) and the siderophore is released. More than 200 different siderophores have been characterized that fall into two major categories: (1) hydroxamates and (2) catecholates (Figure 11.2). An extensive discussion of metal binding can be found in Konhauser (2007).

#### 11.4 ENERGY FLOW: SHUFFLING ELECTRONS; REDOX REACTIONS

In oxidation, compounds lose one or more electrons, while in reduction, compounds gain one or more electrons. Energy generated during redox (reduction–oxidation) reactions is stored in compounds such as ATP. When a hydrogen atom loses an electron, it becomes a proton. Because the electrons cannot dwell in solution as just electrons, they seek to become part of other atoms or molecules. Thus, the following reaction is termed a *half-reaction*, the half that represents the oxidation reaction:



This reaction will be coupled to another half-reaction that represents the reduction reaction, which in the case below is the reduction of oxygen gas. Together they form a complete redox reaction, composed of two half-reactions:



The overall balanced reaction from these two half-reactions is



In this reaction,  $\text{H}_2$  has been oxidized and is the electron donor, while the oxygen has been reduced and is the electron acceptor. To understand these reactions, follow the change in valence state of each molecule or compound.  $\text{H}_2$  (electron donor) with a valence of 0, loses its two electrons to become  $2 \text{H}^+$ , where each  $\text{H}^+$  has a valence of +1. Oxygen,  $\text{O}_2$  (electron acceptor), changes from a valence of 0 to a valence of  $-2$  as it gains two electrons when it is reduced to water.

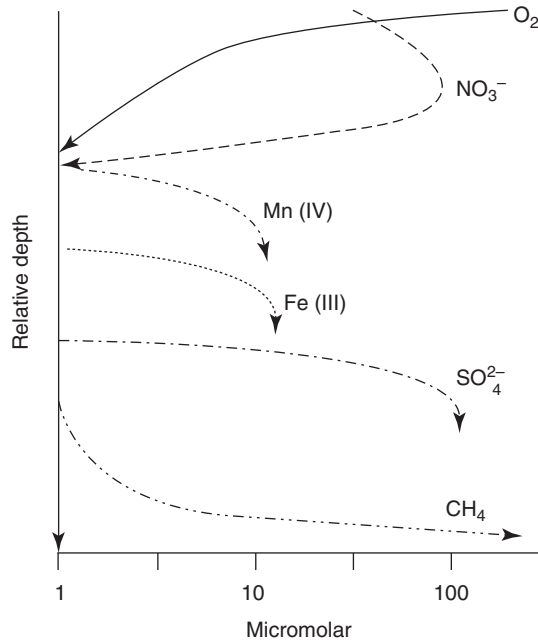
Each of the abovementioned substances has an associated electrode potential that measures its likelihood of accepting or donating electrons at standard conditions of pH 7, 1 atm, and  $25^\circ\text{C}$ , which is expressed in volts (V) as  $E^{\circ'}$ . For example, reaction (11.1) has an  $E^{\circ'}$  of  $-0.41 \text{ V}$ , while reaction (11.3) has an  $E^{\circ'}$  of  $+0.82 \text{ V}$ . The negative  $E^{\circ'}$  value indicates that hydrogen is a very good electron donor, and the positive  $E^{\circ'}$  value indicates that oxygen is a very good electron acceptor. Together, this oxidation–reduction reaction, has a primary electron donor (PED) and a terminal electron acceptor (TEA). The difference in the electrode potentials between the PED and TEA represents the net free-energy change in the reaction under standard conditions, which is called the *standard Gibbs free energy* ( $\Delta G^{\circ'}$ ). If the  $\Delta G^{\circ'}$  is negative, the reactants may have more free energy than the products and the reaction will be *exergonic* (energy-releasing).

Electron acceptors are important requirements for microbial growth, and in environments ranging from oxic to anoxic, distinct biogeochemical zones are observed. With an organic-rich environment, the mineral environment will select physiological groups of chemolithotrophic bacteria and archaea based on the redox potential of the environment (Figure 11.3). In a suboxic environment, nitrate serves as an electron acceptor with the production of nitrite by a selected group of microorganisms. Alternately, physiologically different groups of microorganisms will reduce nitrate to dinitrogen ( $\text{NO}_3^-/\text{N}_2 = +751 \text{ mV}$ ) or to ammonium ( $\text{NO}_3^-/\text{NH}_4^+ = +363 \text{ mV}$ ). As the reducing activity in the environment increases, microorganisms will grow by using Mn(VI), Fe(III), sulfate, or carbon dioxide as electron acceptors. The transition of biogeochemical zones in water systems is relatively gradual, and a mixture of species in the water columns results. The depths at which these zones are found may be a few centimeters at the mud–water interface or may extend for several meters in marine environments. Similar biogeochemical zones may be found in thick biofilms and surrounding particulate organic material in soil or freshwater environments.

Redox reactions are a critical part of biomineralization. We suggest consulting Konhauser (2007) for a more extensive discussion of these concepts. Ascertaining what electron acceptors and donors are available in a given environment is critical to understanding the potential geomicrobiological interactions that lead to biomineralization.

## 11.5 DISSOLUTION VERSUS PRECIPITATION

Biomineralization can result in the precipitation, formation of biogenic compounds, or dissolution (the erosion or corrosion of substrates). For example, in microbial carbonates (Section 11.9), some microbial processes lead to dissolution of carbonate, rather than



**Figure 11.3.** Idealized profile of zonation of microorganisms based on sequential utilization of electron acceptors.

precipitation. Microbial dissolution of carbonates is of great interest because of the large reservoir of carbon contained within them, their role as pH buffers in aqueous habitats, their role in partially regulating pollutants, and microbial degradation of stone monuments and buildings of our cultural heritage. Dissolution of carbonates is carried out by a wide array of microorganisms, including bacteria, archaea, fungi, algae, and lichens and stems from their metabolic byproducts. Such products include exopolysaccharides (a major component of biofilms), siderophores and other secreted chelators, organic acids, and even the bacterial cell wall (Perry et al. 2004). Several examples of both will be given in the following sections.

## 11.6 FORMATION OF ORES AND MINERALS

In low-temperature, aqueous habitats with oxygen, bacteria can affect the dissolution or precipitation of minerals through their reduction or oxidation of compounds containing Mn, Fe, S, C, U, Cu, Mo, Hg, and Cr. Many of the important bacteria in ore-forming habitats are heterotrophic, metabolizing organic carbon to carbon dioxide, coupled to inorganic substances reduction. Where the habitat space is reducing in nature, anaerobic bacteria dominate. The redox reactions that bacteria carry out to provide the energy for their activities can affect the solubility of metals in their environments, through the release of metabolic byproducts. These events can lead to the liberation of ore metals from minerals or rocks or to ore formation. Studies have considered the role of bacteria in the formation of ferromanganese nodules, sedimentary iron formations, and sulfur deposits [reviewed in Southam and Saunders (2005)].

The bacterial role in the liberation of metals from minerals and rocks has been studied in metal sulfides, silicates, and apatite, for example. The bacterial role in generating acidity as they oxidize sulfides for energy generation, is well known. Bacteria can also work in tandem, leaching, and concentrating, as is seen in environments where acidophilic, iron-oxidizing bacteria leach copper deposits, which are later concentrated by the actions of sulfate-reducing bacteria and abiological factors (Southam and Saunders 2005). Silicate minerals, especially in the presence of abundant organic compounds, can be rapidly dissolved. Many of these processes also happen abiotically, but occur many times faster with bacterial assistance.

### 11.6.1 Biomining

*Biomining* is the use of microorganisms to aid in the extraction and recovery of metals from ores. Although unknown to the Roman miners of the time, bacteria helped to mine copper in the 1500s. Miners used the water of the Rio Tinto on copper deposits to dissolve the copper, which then reprecipitated in recoverable deposits. The Rio Tinto contained high levels of microbially produced oxidized iron and was acidic (McPhee 2008), which aided the copper dissolution. This inadvertent use of microorganisms foreshadowed the biomining industry of today. Currently, the mining industry uses microorganisms in a variety of ways that range from a dump of low-grade ore to a highly structured heap that is aerated with carbon dioxide and oxygen, irrigated with acidic solutions, and sometimes insulated? to the newer stirred-tank reactors (aerated, continuous flow) for the pretreatment of more valuable ores (Rawlings and Johnson 2007). These three approaches vary in cost significantly and in their environmental conditions. The microorganisms that grow in this aerobic, lithotrophic, and acidic environment are usually chemolithoautotrophic, using reduced forms of sulfur and iron, and acidophilic. The stirred-tank reactors have a fairly homogeneous environment that provides limited niches, resulting in smaller microbial communities (Table 11.1). Because minerals introduced into these reactors are not sterile, the community of microorganism evolves over time through natural selection and recruitment, and becomes more efficient, eventually achieving what appears to be a climax community. This evolution and the degree to which a “best” community of microorganisms can be achieved, are active areas of research (Rawlings and Johnson 2007). Another form of biomining is the use of bacteria to enhance the recovery of petroleum.

### 11.6.2 Recovery of Petroleum

Microorganisms both consume and produce the hydrocarbons and other organic substances found in petroleum, which has made them the target of investigations. Bacteria and archaea live autotrophically on the hydrogen, sulfur, and carbon dioxide present in petroleum reservoirs, and heterotrophically on the hydrocarbons and other organic compounds. In the early 1920s, researchers suggested that microorganisms might be useful in the recovery of heavy crude oil and research into this blossomed in the 1980s and beyond (Van Hamme et al. 2003). Conditions in petroleum reservoirs limit the bacteria and archaea that can successfully grow there. High sodium chloride concentrations require a tolerance for high salinity, and higher temperatures require thermophilic organisms. A variety of bacteria and archaea play different roles in enhancing oil recovery (Table 11.2). Some of these organisms produce biosurfactants that help to emulsify petroleum constituents, decrease interfacial tension, and reduce viscosity. Other organisms produce

TABLE 11.1. Acidophilic Organisms Found in Stirred-Tank Reactors<sup>a</sup>

Minerals	Acidophilic Organisms Present
Lead/zinc pyrite	<i>Leptospirillum ferriphilum</i> , <i>Acidithiobacillus thiooxidans</i> , <i>Acidiphilium cryptum</i> , <i>Acidithiobacillus ferrooxidans</i> .
Pyrite/arsenopyrite (gold)	<i>Leptospirillum ferriphilum</i> , <i>Acidithiobacillus caldus</i> , <i>Acidithiobacillus ferrooxidans</i> .
Cobaltiferous pyrite	<i>Leptospirillum ferrooxidans</i> , <i>Acidithiobacillus thiooxidans</i> , <i>Sulfobacillus thermosulfidooxidans</i> .
Polymetallic (copper, zinc and iron sulfides)	<i>Leptospirillum ferriphilum</i> , <i>Acidithiobacillus caldus</i> , <i>Sulfobacillus</i> sp., <i>Ferroplasma acidophilum</i> .
Pyrite, arsenical pyrite and chalcopyrite	<i>Acidithiobacillus caldus</i> , <i>Sulfobacillus thermosulfidooxidans</i> , ' <i>Sulfobacillus montserratensis</i> '.
Chalcopyrite	<i>Sulfolobus shibitae</i> , <i>Sulfurisphaera ohwakuensis</i> , <i>Stygiolobus azoricus</i> , <i>Metallosphaera</i> sp., <i>Acidianus infernus</i> .

<sup>a</sup>The first five mineral environments are mesophilic (35–45°C), while the chalcopyrite is thermophilic (78°C). The latter contains likely new archaeal species, whose closest relatives are listed in the table.

Source: Modified from Rawlings and Johnson (2007).

TABLE 11.2. Microorganisms and Their Roles in Enhancing Petroleum Recovery

Role in Oil Recovery	Microorganisms Involved
Selective biomass plugging	<i>Bacillus licheniformis</i>
Reduction of viscosity	<i>Leuconostoc mesenteroides</i>
Alteration of wettability; oil degradation	<i>Xanthomonas campestris</i>
Emulsification, interfacial tension decrease, viscosity reduction through biosurfactant production	<i>Acinetobacter calcoaceticus</i> <i>Arthrobacter paraffineus</i> <i>Bacillus licheniformis</i> <i>Clostridium pasteurianum</i> <i>Corynebacterium fasciens</i> <i>Pseudomonas rubescens</i>
Mobility control, injectivity profile modification through biopolymer production	<i>Bacillus polymyxa</i> <i>Brevibacterium viscogenes</i> <i>Leuconostoc mesenteroides</i> <i>Xanthomonas campestris</i>
Viscosity reduction oil dissolution through solvent production	<i>Clostridium acetobutylicum</i> <i>Clostridium pasteurianum</i> <i>Zymomonas mobilis</i>
Emulsification, increase in permeability through acid production	<i>Clostridium</i> spp. <i>Enterobacter aerogenes</i>
Increase in permeability, reduction in viscosity, interfacial tension decrease, increased pressure, oil swelling through gas production	<i>Clostridium acetobutylicum</i> <i>Enterobacter aerogenes</i> , <i>Metallosphaera</i> sp., <i>Methanobacterium</i> sp.

Source: Modified from Van Hamme et al. (2003).

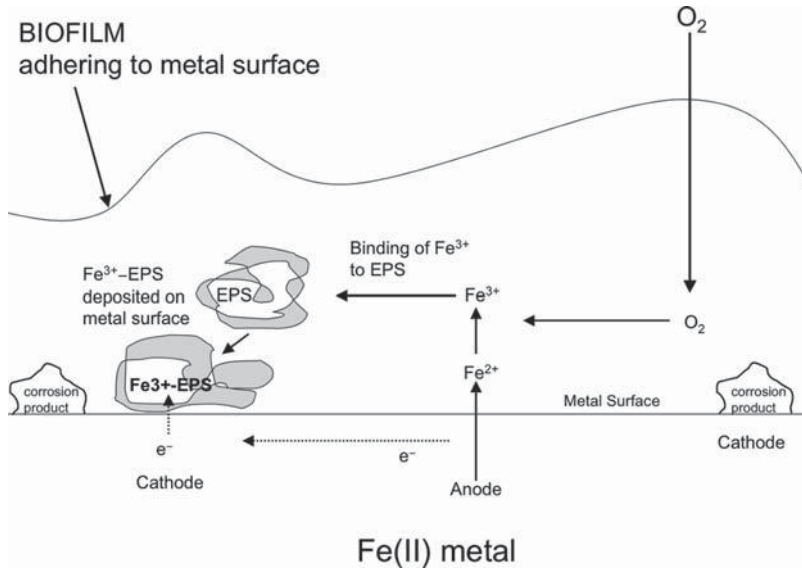


organic acids that dissolve surrounding carbonates, which enhances the permeability of the reservoir. Solvents produced by organisms such as *Clostridium* spp. and *Zymomonas mobilis*, can decrease viscosity of the oil. The gases that result from fermentation, such as carbon dioxide, methane, and hydrogen, work to repressurize the wells. The biomass of the microorganisms and their biopolymer byproducts can plug pores in reservoirs to allow for the recovery of residual oil (Van Hamme et al. 2003). Researchers select for organisms that are thermophilic and halophilic and inject these organisms into reservoirs to produce many of the effects listed in Table 11.2. These organisms are truly bioengineers and biominers. Because conditions vary from reservoir to reservoir and because it is difficult to control the microorganisms once they are in the reservoir, this is less than a perfect biotechnology process.

Corrosion of metals and their alloys is of major economic importance in water pipes, ship hulls, and other metallic substances, where corrosion can have disastrous effects. Metals are corroded through electrochemical interactions between the metal and the surrounding environment, and these interactions are influenced by the physico-chemical aspects of the environment, or through the activity of microorganisms. In either case, electrons from the surface of the metal are transferred to an electron acceptor, which is reduced as a consequence. These reactions involve anodic (oxidation) and cathodic (reduction) reactions at or near the surface of the metal (Figure 11.4). When bacteria are involved, they facilitate these reactions and may either initiate the dissolution, or can accelerate the rate at which dissolution occurs. Among the most studied bacteria involved in microbially influenced corrosion (MIC) are organic acid and slime-producing bacteria, manganese-oxidizing bacteria, iron-reducing/oxidizing bacteria, sulfur-oxidizing bacteria, and the sulfate-reducing bacteria (SRB). The byproducts of other MIC bacteria, such as manganese oxides, create anaerobic pockets on metal surfaces, which provide good habitats for the SRB. One of the classic corroding SRB is *Desulfovibrio vulgaris*. Evidence from the study of the genome of *D. vulgaris* and other studies suggests that SRB acquire electrons from the metal surface via the actions of hydrogenases, confirming a role for enzymes in MIC (Beech and Sunner 2004).

The degree to which corrosion of metals is caused by microorganisms versus purely chemical mechanisms is the focus of intensive study, especially in aqueous environments. Some researchers have suggested that microbially produced enzymes increase the free corrosion potential of stainless steel, a process that is called *ennoblement* (Beech and Sunner 2004). Extracellular polymeric substances (EPSs) or slime, are also key in MIC. The EPS forms the structure of the biofilm that develops on metal surfaces, and metal ions bind to the negatively charged functional groups within the biofilm. Biofilms form on metallic surfaces as microorganisms attach to the surface, bind, begin to develop EPS, and create corrosion products (Figure 11.4). This series of actions can lead to changes in the physicochemical conditions, which can increase corrosion.

Various control mechanisms for MIC have been developed to limit economic losses and catastrophic failures. Early efforts utilized biocides to control the microorganisms present, but biocides have problems associated with them, including microbial resistance. Therefore, more green technologies are under development, based on our knowledge of how MIC works. These green strategies involve preventing corrosion by the use of biofilms and manipulating resident microorganisms through electron acceptor changes (Little et al. 2007). Inhibitory biofilms, as opposed to corrosion-enhancing biofilms, work by providing diffusion barriers that limit corrosion, consuming oxygen that would be used as an electron acceptor by corroding microorganisms, producing antibiotics that are



**Figure 11.4.** Microbially influenced corrosion of a ferrous iron surface. Microorganisms attach to the metal surface and grow into a biofilm that is composed of the microorganisms and EPS. As the microorganisms oxidize the reduced iron in the metal, they release electrons. The oxidized iron binds to the EPS and deposits on the surface of the metal. The released electrons are used to reduce the oxidized iron bound to the EPS, completing the redox cycle. [Modified from Beech and Sunner (2004).]

effective against corroding microorganisms, and producing metabolic products that inhibit corrosion. While this research is promising, some results are confusing and demonstrate that the same organisms can both cause and inhibit corrosion. The addition of nitrate, an alternative electron acceptor to sulfate, can lead to a competitive exclusion of SRB, diminishing corrosion. These are promising green technologies that have yet to prove their worth in commercial operations (Little et al. 2007).

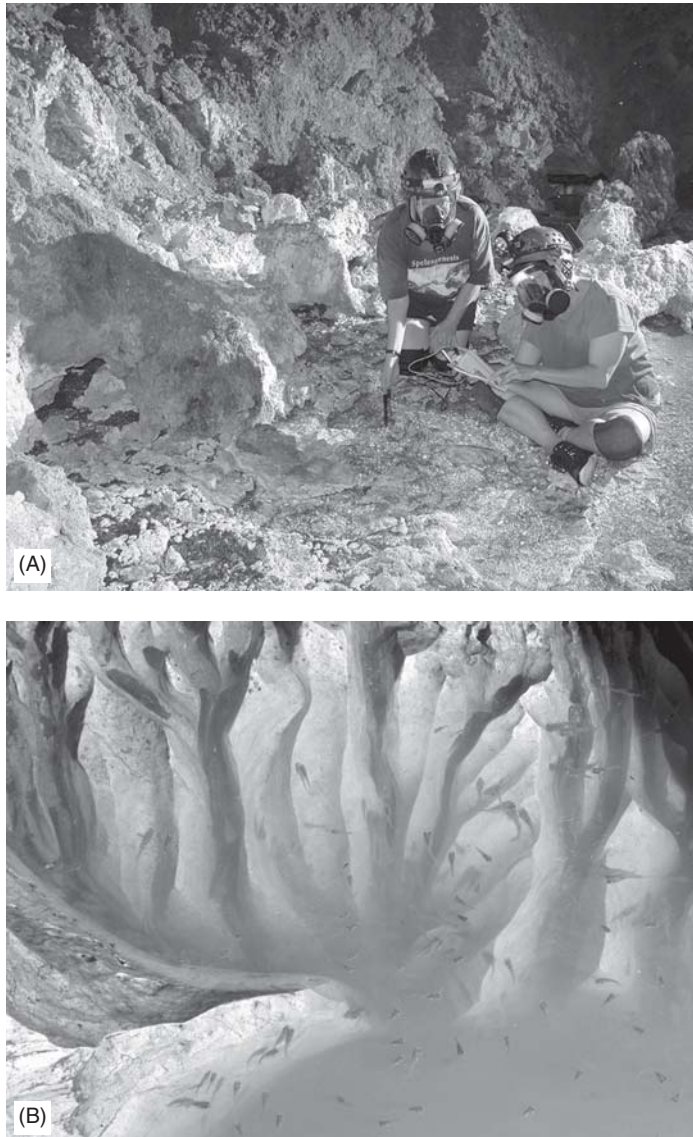
### 11.6.3 Sulfuric Acid–Driven Speleogenesis

Abundant life exists below Earth's surface, which is primarily microbial. These microorganisms produce metabolic products and selectively reduce or oxidize mineral constituents of rocks and soils, which can lead to microbially mediated dissolution and diagenesis (Ehrlich 2002). One spectacular example of the result of such dissolution is the creation and enlargement of caves by the action of sulfuric acid (sulfuric acid–driven speleogenesis), some of which is produced by microorganisms as a byproduct of the oxidation of hydrogen sulfide.

Sulfuric acid–driven speleogenesis creates some limestone caves when hydrogen sulfide gas rises along fissures until it encounters oxygenated water and is oxidized to sulfuric acid, which dissolves the limestone (Jagnow et al. 2000). Biogenic production of sulfuric acid directly by microbes also contributes to such cave formation (Engel et al. 2004). Examples include Carlsbad Cavern and Lechuguilla Cave in the Guadalupe Mountains of New Mexico (USA), Movile Cave (Romania), and Cueva de Villa Luz

(Mexico) (Figure 11.5). If you've ever walked the corridors of Carlsbad Cavern's Big Room (Figure 11.6), you will be astounded by the evidence of what microbially mediated corrosion can do.

Molecular phylogenetic studies of acidic biofilms in Cueva de Villa Luz and caves of the Frasassi Gorge (Italy) demonstrate the presence of *Thiobacillus* and *Acidithiobacillus* spp. These thiobacilli gain energy from the oxidation of sulfur or sulfide to sulfuric acid



**Figure 11.5.** (A) Hydrogen sulfide enters Cueva de Villa Luz, through springs, and oxidizes to elemental sulfur, seen around the orifice of the spring; (B) microbially produced sulfuric acid carves ruts, called *rillenkarren*, in the limestone walls as it runs down them (photos courtesy of Kenneth Ingham). See insert for color representation.



**Figure 11.6.** Carlsbad Cavern's Big Room, New Mexico, USA, spans six football fields (photo courtesy of Peter Jones, Shot in the Dark Cave Photography).

and can contribute to dissolution of carbonate in these caves. Such sulfuric acid–driven speleogenesis is implicated in the formation of numerous caves throughout the world and as a major contributor to enlargement in an active sulfur cave (Figure 11.5). These sulfur cycle microorganisms also provide a substantial boost to the food web in these caves.

## 11.7 MICROBIAL PARTICIPATION IN SILICIFICATION

### 11.7.1 Silica Formation in Diatoms, Radiolarians, and Sponges

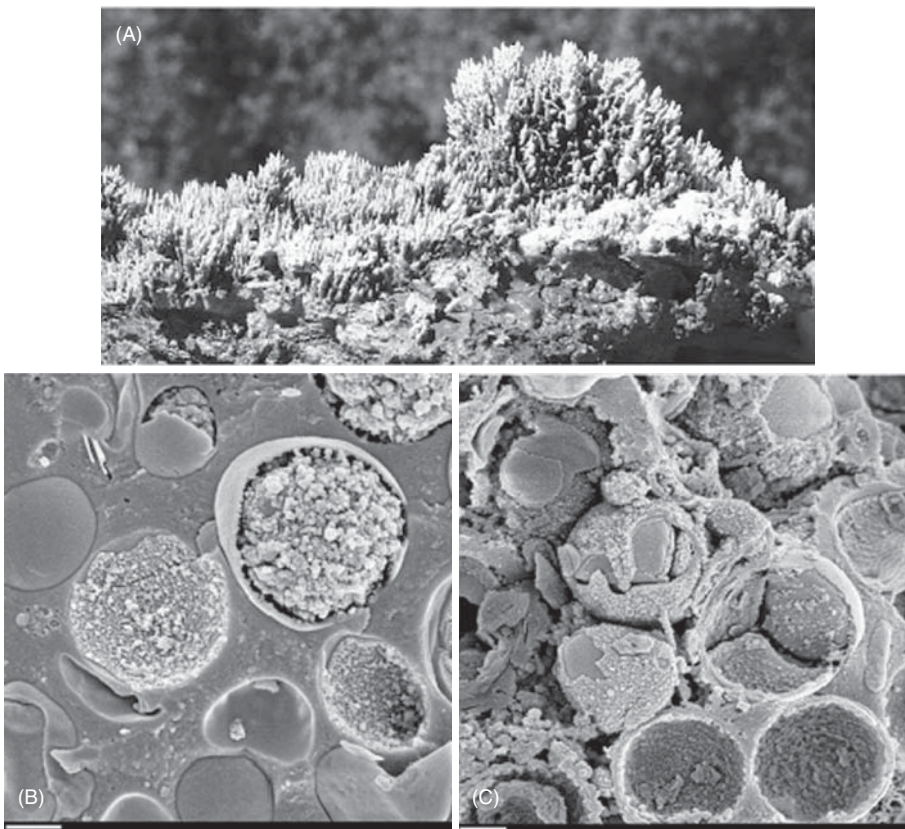
As noted previously (Section 2.9.1), diatoms build nanocrystalline silica (also called *opal A*) walls. Similarly, radiolarians, ameboid protozoa with filamentous pseudopods, provide an excellent example of biologically controlled mineralization and are important because of their impact on silica in aqueous environments, driving down the amount of silica present. Why use a mineral that is not abundant, in a process that is energetically expensive? Diatoms compensate for the silica formation with light photosynthesis and respiration of glucose during darkness. They have developed a specialized structure, called the *silica deposition vesicle*, which resides within the cell, bound to the membrane. Cells then actively pump silicic acid from the outside environment across the plasma membrane, and the membrane (called the *silicalemma*) of the silica deposition vesicle and polymerization proceeds, resulting in nanoscale colloids on the inner side of the silicalemma. Through active processes on the part of the diatom, the silica binds very tightly to the membrane surface. Active control on the part of the diatom results in the intricate silica shells, called *frustules*, which are a hybrid of the inorganic silica, and proteins provided by the diatom. Further details of this process can be found in Konhauser (2007). As suggested in Section 2.9.1, predator protection may be one of the main driving forces for using silica for external protection. On its death and descent to the bottom sediments, diatom biomass is attacked by bacteria that expose the silica



to the disequilibrium of the external aqueous environment, where it returns to solution and diffuses or is transported to surface waters to be reused by other organisms. Those organisms are not degraded but are buried in the bottom sediments, forming thick silica-rich deposits. Silica biomineralization is also seen in sponges where amorphous silica spicules are created by sponges of the classes Hexactinellida and Demospongiae.

### 11.7.2 Geyserrites

Geysers and hot springs can be adorned with siliceous sinters at or near the air–water interface around the edges of the pools created by hot springs or geysers or along the pool outflow margins. In form they are small, pinnacle-like structures that narrow to a rounded point. When several cluster together, they are termed *spicular geyserrites* (Figure 11.7A) and when not in clusters, they have been termed *microstromatolites*. The degree of biogenicity or abiogenicity is a matter of vigorous debate. Extensive studies by Jones and Renault (2006) have found that siliceous spicules in the Waiotapu geothermal region of New Zealand are more commonly found in hot ( $>50^{\circ}\text{C}$ ), acidic waters that are dominated



**Figure 11.7.** (A) Macroscopic view of siliceous spicules from a pool margin in the Waiotapu geothermal region of New Zealand; (B,C) photomicrographs of the silicified microorganisms (photos courtesy of Brian Jones).

by sulfate or sulfate chloride. The spicules of this region have a central core of opal A silica that is low in porosity and permeability. A very porous and permeable outer layer covers this core. Distinct layers occur within the spicule, which are characterized by specific microbial populations, or no microorganisms. The layers containing silicified microorganisms (Figure 11.7B,C) have unicellular algae, including putative *Cyanidium caldarium* and *Galdieria sulphuraria*, and bacilliform microorganisms. The concentration of silica in the water is the major controlling factor of spicule development, but the growth of algae or the bacilliform microorganisms on the spicules when environmental conditions are favorable contributes to spicule development. These microbial mats are bathed in silica-rich water from steam condensate, rain, spray, and changes in water levels over time. Jones and Renaut (2006) suggest that spray and splashing can be important mechanisms in spicule growth, while water-level changes due to a variety of causes can promote microbial colonization of the spicules. The algae and bacilliform microorganisms present in the spicules appear to passively promote silica precipitation as silica-rich waters bathe the microbial mats. The different layers within the spicules, some with microorganisms and some without, suggest that abiotic and biotic processes contribute to spicule formation and provide a fertile ground for investigation of the interplay between abiotic and biotic processes.

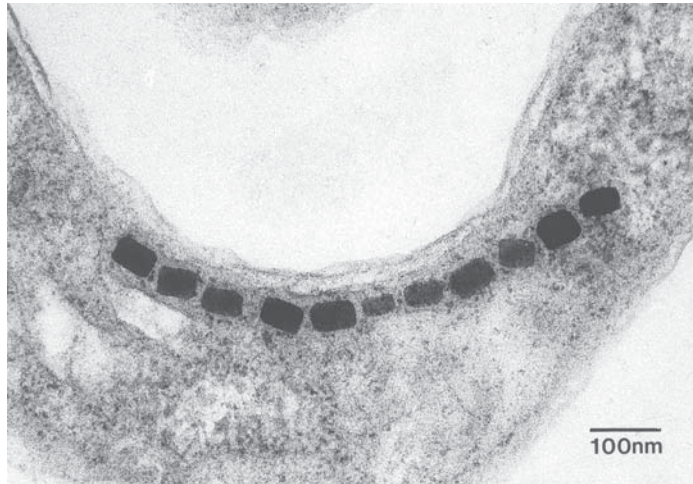
## 11.8 BIOMINERALIZATION OF FERROMANGANESE DEPOSITS

### 11.8.1 Magnetite Formation

Microbial formation of magnetite is accomplished by both biologically induced mineralization (BIM) and biologically controlled mineralization (BCM). Magnetite formation is an important process because of its contribution to the iron biogeochemical cycle, the contribution of magnetite-forming bacteria to magnetization of sediments, and magnetite's use as a biomarker for the presence of magnetic bacteria in the fossil record of our planet and Mars. Additionally, magnetotactic bacteria (Figure 11.8) are a fun educational tool. In the Woods Hole Microbial Diversity course, one of the experiments has students examine magnetotactic bacteria under the microscope. When you apply a magnet to the side of the microscope slide, all the magnetotactic bacteria "run" toward the magnet, creating a fun and fascinating visual display.

Although many details remain to be worked out, several key features of magnetite formation have been elucidated (Bazylinski et al. 2007) in both BIM and BCM. BIM of magnetite is carried out by *Geobacter metallireducens* and *Shewanella putrefaciens*, two examples of dissimilatory Fe(III) reducers that reduce the  $\text{Fe}^{3+}$  in ferric oxyhydroxides, coupled to the oxidation of fermentation products. These and other iron-reducing bacteria epicellularly form poorly crystalline, irregularly shaped magnetite, which ranges in size from 10 to 50 nm. These crystals are generally *superparamagnetic*, meaning that they are not magnetic at ambient temperatures. Such crystals can also be produced abiologically at around pH 7 by the reaction of  $\text{Fe}^{2+}$  with ferrihydrite.

In contrast, BCM is carried out by an assortment of Gram-negative, aquatic bacteria, which produce a highly crystalline and very pure form of magnetite, called *magnetosomes*. These magnetosomes range in size from 35 to 120 nm and are permanently magnetic, allowing the bacteria to create a permanent magnetic dipole. Magnetotactic bacteria use the magnetite crystals to align and move themselves along geomagnetic field



**Figure 11.8.** Magnetite crystals are visible within this magnetotactic bacterium (photo courtesy of Dennis Bazylinski).

lines, within their habitat at the oxic–anoxic interfaces in sediments. These bacteria are occasionally facultative chemolithoautotrophs (oxygen is the terminal electron acceptor), but are generally chemoheterotrophs. These magnetotactic bacteria display magnetotaxis, which enables them to align themselves and swim along magnetic field lines. The current model of magnetosome formation involves several steps, which have been proposed to include (Bazylinski et al. 2007) the following:

1. Procurement of  $\text{Fe}^{3+}$  from the environment using siderophores
2. Attachment of siderophore-  $\text{Fe}^{3+}$  complex to the cell's outer membrane.
3. Transport of this complex into the cell where it is reduced to  $\text{Fe}^{2+}$
4. Transport of reduced iron to the magnetosome membrane
5. Reoxidation of  $\text{Fe}^{2+}$  to ferric hydroxide, which reacts with more dissolved  $\text{Fe}^{2+}$  and crystallizes as magnetite

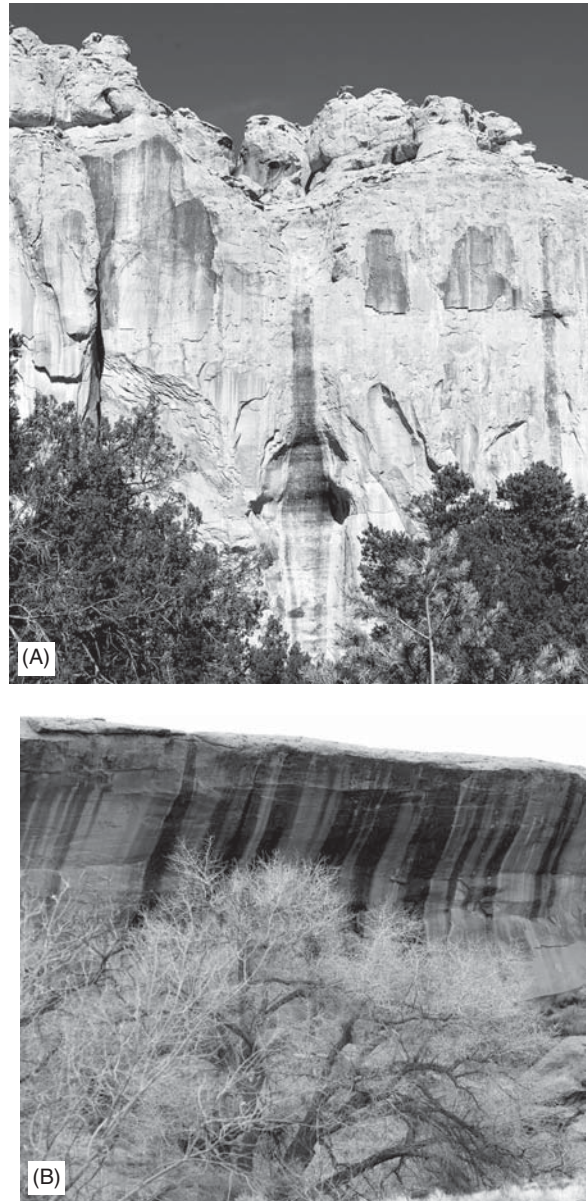
Other evidence suggests a direct conversion of  $\text{Fe}^{3+}$  to magnetite. Some investigations have also suggested that protists may be involved in magnetite ingestion or biomineralization.

Magnetite that is formed through BCM is an energetically expensive process, which has caused scientists to wonder why bacteria would perform magnetite formation. Our best hypothesis is that this ability allows the bacteria to more efficiently move toward energy sources. As we study this intriguing process, we can agree with Bazylinski and Schüller (2009), who said: “The magnetosome chain is a microbial structural masterpiece.”

### 11.8.2 Rock Varnish

Rock, or desert varnish, occurs as a dark, black-brown-colored coating enriched with manganese (Mn) and iron (Fe) oxides with a typical thickness rarely exceeding 200  $\mu\text{m}$  on rocks worldwide, but is especially observed in arid and semiarid regions (Figure 11.9).





**Figure 11.9.** (A) Desert varnish on the cliffs of El Morro National Monument, New Mexico, USA; (B) desert varnish on the cliffs of Chaco Canyon National Park, New Mexico (photos courtesy of Kenneth Ingham).

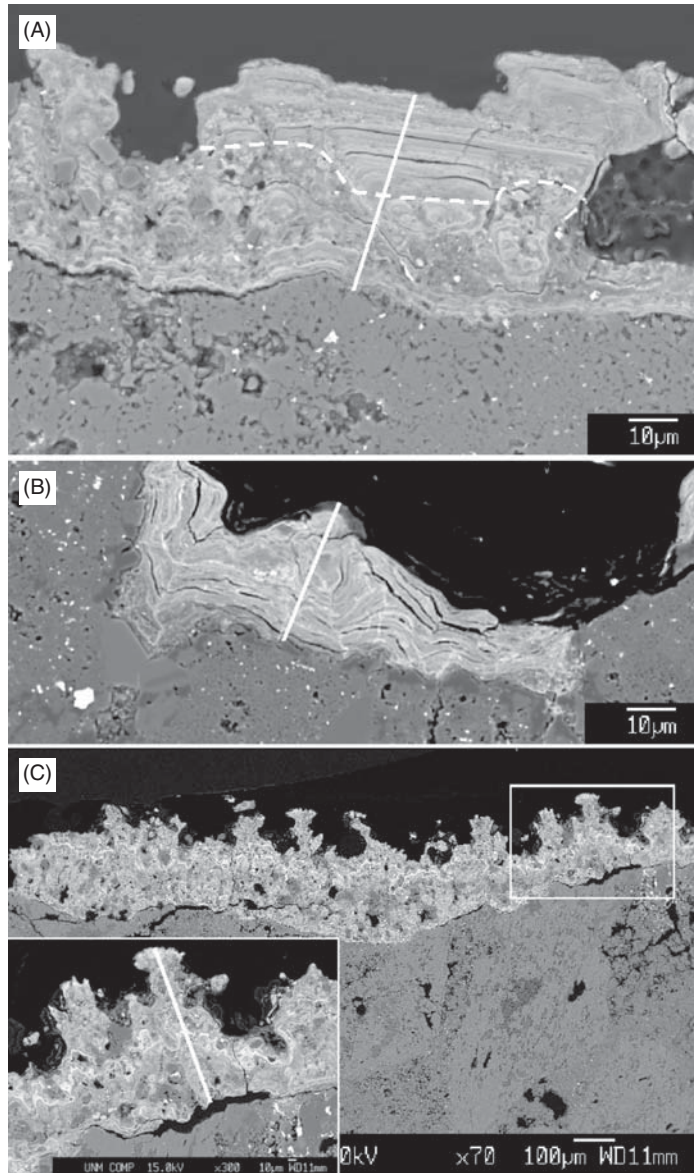
Rock varnish has stimulated a lot of interest since the 1990s because of its potential as a dating tool, the insights that it might provide into paleoclimates, its role as an analog for similar features on Mars, the ability of resident microorganisms to survive desiccation and high levels of ultraviolet radiation in part due to the protective covering of ferromanganese deposits, and finally, the hotly debated issue of whether varnish is microbially mediated

or purely abiotic in origin. Rock varnish is composed primarily of clay minerals that are cemented to rock by Mn and Fe oxides in a laminated structure resembling the morphology of stromatolites (Figure 11.10). Evidence is mounting that microbes can directly or indirectly control Mn precipitation (Tebo et al. 2004) and biomineralization of manganese has been suggested in various environments, including marine nodules, hot springs, freshwater sediments, soils, and caves. Evidence for a biological origin for rock varnishes is based on microscopic and culture-based results suggesting that bacteria are intimately associated with varnish coatings. The strongest arguments for biogenicity are the presence of organisms able to precipitate Mn and the stromatolitic texture of varnishes. Culture-independent studies of DNA sequences present suggest that a similar community is found in varnishes from different areas of the world. The composition of the varnish community, with many sequences of Cyanobacteria and Chloroflexi present, suggests that these organisms may be the base of the food web in the varnish, supporting the activities of chemolithotrophic manganese-oxidizing bacteria.

### 11.9 MICROBIAL CARBONATE MICROBIALITES

The possibility that microorganisms were involved in carbonate precipitation was suggested in the late 1800s by Wollny, followed by several other investigators. Microbially produced organosedimentary benthic deposits are called *microbialites*. Carbonate precipitation has been documented in bacteria (in particular cyanobacteria), algae, and fungi, often within a microbial mat, found in aqueous environments (springs, marine, and lakes), soils, and caves. *Microbial carbonates* are the product of a combination of biological and abiotic factors. EPS produced by the microorganisms can be a key part of trapping sediments and enhancing nucleation. Microorganisms can alter the saturation index (SI) of surrounding solutions, or can remove inhibitors of crystallization, such as magnesium, sulfate, or phosphate ions, through binding or metabolism. In surface environments, photosynthetic uptake of carbon dioxide or bicarbonate ions by cyanobacteria can lead to an increase in alkalinity, which shifts the chemical equilibrium, leading to precipitation of carbonate. Other metabolic processes, such as ammonification, sulfate reduction, and denitrification, will also increase alkalinity, causing biologically induced carbonate production (Riding 2000). One rationale for microbial carbonate precipitation is to prevent the accumulation of toxic levels of  $\text{Ca}^{2+}$ . Others (McConnaughey and Welan 1997) have suggested that calcification is used to acquire nutrients, especially in low-nutrient and low-light conditions through an active  $\text{Ca}^{2+}/\text{H}^{+}$  transport mechanism.

The details of and rationale for carbonate biomineralization are slowly being revealed. Some of the most elegant experiments demonstrating calcium carbonate precipitation by microorganisms were carried out by Chafetz and Buczynski (1992), who suggested that the bacteria could induce precipitation of carbonates. Their experiments were able to show that metabolically active bacterial cultures could produce mineral morphologies in culture that mirrored those seen in lithified mats. Boquet et al. (1973) demonstrated that the ability to produce calcite crystals in culture is a widespread function of soil bacteria, when grown on plates that contained calcium, but no carbonate ions, suggesting that whatever mechanism is involved, it is conserved across multiple taxa. Dense, clotted or peloidal, micritic microfabrics, which are produced as a result of calcification of microorganisms and their biofilms, are considered to be produced at least in part by



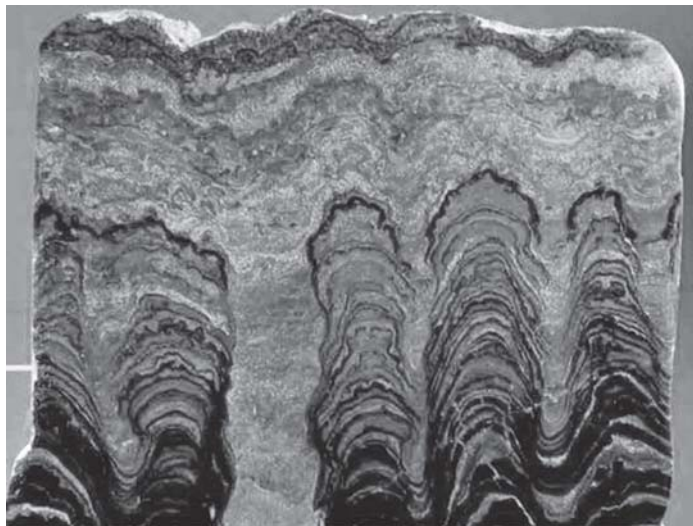
**Figure 11.10.** Backscattered microscopy images from polished sections of rock varnish from near Socorro, New Mexico (in all images, the varnish is lighter gray and the substrate rock is darker gray): (A) layered varnish from site 2 (chaotic layering is present in the lower portion of the varnish, below the uniformly layered region, indicated by dashed line); (B) layered varnish—a discontinuous layer of silica is present on the surface of the varnish; (C) botryoidal varnish (inset: closeup of several pinnacles in the white-outlined box). (Photomicrographs courtesy of Michael Spilde).

microbial biomineralization. Very fine-grained (1–5- $\mu\text{m}$ ) calcite crystals are referred to as *micrite*.

Significant microbial carbonates exist in both marine and freshwater environments. Cyanobacteria, such as *Synechococcus*, have been suggested as the agent of calcium carbonate precipitation during major cyanobacterial blooms, in processes termed “whiting events,” in which carbonate-encrusted microorganisms fall to the bottom of lakes and shallow marine environments as fine muds. Such processes have major impacts on the sequestration of carbon. Other major microbial carbonates include travertine/tufa deposits that are produced through biologically induced mineralization, and the biological controlled mineralization of the coccolithophores (algae) and foraminifera (protozoa), which will be discussed in the following sections. The resultant carbonate deposits from these different processes differ in whether they are laminated (stromatolites) or not (thrombolites). Note these differences as you read through the next sections.

### 11.10 STROMATOLITES

A *stromatolite* is a laminated benthic microbial deposit (Riding 1991). Stromatolites have featured prominently in the fossil record (Figure 11.11) of early life because of their abundance in the shallow marine seas of the pre-Cambrian. Researchers recognized that a microbial component existed in carbonate precipitation in stromatolites from the fossil record and gave us glimpses of the remains of some of the earliest life on Earth. While studies on stromatolites suggested that microbial activity was limited to the trapping of calcite crystals within an algal film growing on the structure, subsequent work demonstrated that changes in the microenvironment through photosynthetic activity induced the precipitation of calcite (Walter 1976).



**Figure 11.11.** Stromatolites from eastern Andes south of Cochabamba, District of Cochabamba, Bolivia, South America (image from [http://commons.wikimedia.org/wiki/File:Proterozoic\\_Stromatolites.jpg](http://commons.wikimedia.org/wiki/File:Proterozoic_Stromatolites.jpg), used under the terms of the GNU Free Documentation License).



There is considerable debate, however, as to whether all structures called *stromatolites* are necessarily biologically constructed (Riding 2000). Laminations form in response to an iterative process that can be either organic or inorganic, so the presence of laminations is not, in and of itself, adequate support for a biological role. Fabrics suggestive of inorganic precipitation include isopachous layers, very fine laminations (e.g., <4  $\mu\text{m}$  thick (Walter 1976)], and cement fabrics (e.g., large crystals). Fabrics suggestive of organic or organically mediated precipitation include irregular layers (particularly those that thicken on high points), preserved organic material, micritic carbonate, and fossilized bacteria (Riding 2000).

Stromatolites that are currently forming in a modern marine environment are found on the margins of Exuma Sound in the Bahamas. A study of the processes active in this formation (Reid et al. 2000) documented three different stages:

- *Mat Type 1*. Sparse population of the putative pioneer species, *Schizothrix* (filamentous), which dominate during times of rapid sediment accretion. *Schizothrix*, a photosynthetic organism, produces EPS, which traps sand grains and actively inhibits aragonite production by the excretion of organic acids and through EPS binding of  $\text{Ca}^{2+}$ .
- *Mat Type 2*. This is the lithification stage, where a continuous EPS layer develops on top as sedimentation slows and ceases, which supports a heterogenous community of heterotrophic bacteria, including sulfate-reducing bacteria. This community promotes aragonite precipitation, and a thin micritic layer develops.
- *Mat Type 3*. A climax community develops, which is dominated by *Solentia*, a coccoid cyanobacterium, which bores into the forming stromatolite and fills in the boreholes with aragonite. This infilling fuses the sand grains into a coherent carbonate crust.
- Succession of the community proceeds to an algal community that does not continue forming the laminated stromatolite structure.

The study by Reid et al. (2000) suggests the processes by which ancient stromatolites may have formed and documents the importance of both the cyanobacterial photosynthetic production and respiration by the heterotrophic bacteria that degrade the EPS layer and contribute to lithification. This study also illustrates how modern geomicrobiological examples can help us deconvolve the processes by which ancient examples formed. We turn now to deposits that do not always show evidence of laminations, or that are defined by their lack of lamination.

### 11.10.1 Thrombolites

Some stromatolite-like microbialites have a clotted (“dense clusters of sand grains and cements”), mottled fabric as opposed to continuous laminations. These are differentiated from stromatolites and are called *thrombolites*. Studies in the Bahamas of modern, large, columnar microbialites that contain both stromatolitic and thrombolitic fabrics (Planavaky and Ginsburg 2009) suggest that the stromatolitic fabrics are subject to metazoan bioerosion, which reworks the fabric, leaving a clotted, mottled fabric. In addition to the boring by metazoans, additional creation of micrite and cementation occur, contributing to the remodeled fabric. Investigators hope that the study of modern examples will continue to shed light on the formation of ancient thrombolites.

### 11.10.2 Travertines and Tufas

*Travertine* is a sedimentary rock that is well loved by those building homes because of its beautiful texture, which was used in ancient Greek and Roman buildings, such as the Roman Colosseum. *Travertine* and *tufa* are terms that many use interchangeably. However, some make a distinction, defining travertine deposits as hard crystalline rock that contains thin, plate-like structures as opposed to macrofossils, while suggesting that tufa is generally indicative of any freshwater carbonate produced under ambient temperatures (Pedley 2009). *Tufa*, such as the tufa towers exposed in Mono Lake (Figure 11.12), often contain the fossilized remains of vegetation near where the tufa formed, creating porosity within the tufa. A key difference, as defined by Pedley (2009) and others is the temperature at which the deposits form, which affects the source of the carbon dioxide involved in the mineral precipitation and the organisms that are present. Both types of deposit form as a result of biological and abiological processes, but the relative importance of each has been extensively debated. In hot, turbulent water, pressure reduction, cooling temperatures, and evaporation promote carbon dioxide degassing on emergence from the spring, creating a shift in the chemical equilibrium that leads to carbonate precipitation



**Figure 11.12.** (A) Tufa towers on Mono Lake, California, USA (image courtesy of Kenneth Ingham); (B) closeup of macrofossils in the tufa towers on Mono Lake, (image courtesy of Kenneth Ingham); (C) plant material, hanging into the outflow of a hot spring, in the early stages of lithification. See insert for color representation.



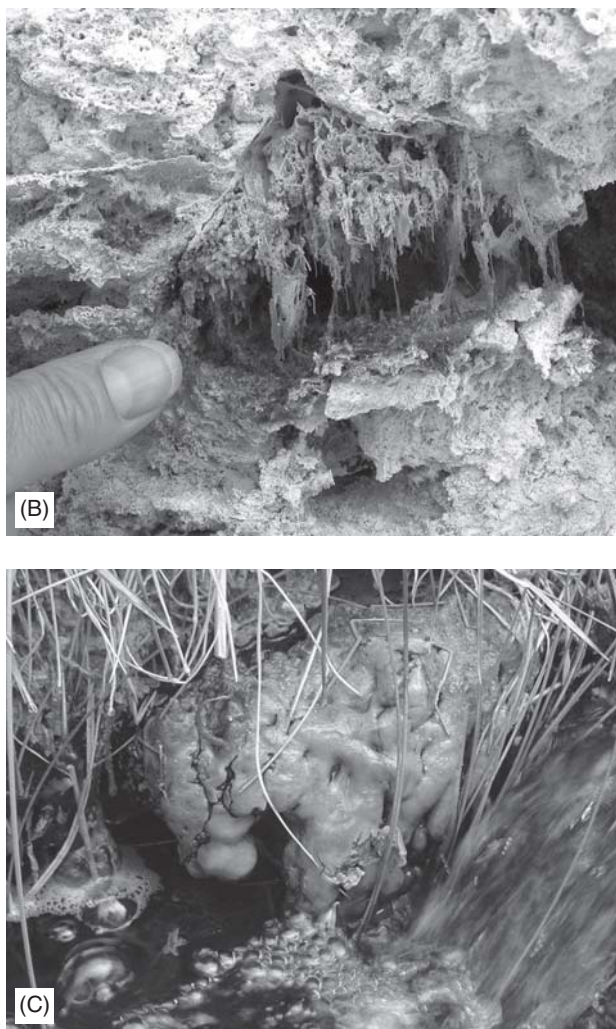


Figure 11.12. (Continued)

abiologically. As the temperature falls from the vent source to farther downstream, the community of organisms changes significantly. However, in the absence of such conditions, as in lakes, it is impossible for these mechanisms to be dominant (Figure 11.13). In cooler, calmer waters, cyanobacteria, algae, diatoms, and plants carry out photosynthesis, which removes carbon dioxide from the water, shifting the chemical equilibrium. Bacterial negatively charged cell walls, and EPS formation by many microorganisms, also facilitate precipitation of carbonate passively in these environments.

Chafetz and Folk (1984) examined calcite precipitation in freshwater travertine deposits. These investigators recognized that the high temperatures and sulfide chemistry of these environments limited algal growth and photosynthesis. They were able to demonstrate that many travertine deposits have significant bacterially mediated carbonate precipitation, with as much as 90% of the framework of the travertine in



**Figure 11.13.** A massive travertine deposit, called Soda Dam, near Jemez, New Mexico, USA (image courtesy of Kenneth Ingham).

lake deposits that was bacterially precipitated. Other deposits, with hotter, harsher conditions, were predominantly inorganic, although some bacteria were able to colonize these environments and contribute to carbonate precipitation. Local geochemistry, temperature, rate of CO<sub>2</sub> offgassing and precipitation, and microbial activity, all play critical roles in carbonate deposition and structure.

Another freshwater example shows the impact of calcium-rich groundwater seepage into an alkaline lake environment. Located in Turkey, Lake Van is the largest soda (alkaline) lake (pH of 9.7–9.8) in the world and the fourth largest “closed water body” in the world. It’s also the site of giant microbialites (tufa towers) up to 40 m in height, which were investigated to shed light on the hypothesis that the early Earth’s oceans might have been alkaline in nature. In some areas of Lake Van, calcium-rich groundwater enters the alkaline lake water, and physicochemical factors lead to the precipitation of calcite. These inorganic carbonate deposits are then colonized by unicellular, coccoid cyanobacteria, which induce aragonite precipitation, contributing to the growth of the microbialite (Kempe et al. 1991). This is a dynamic process with groundwater continuing to add to the microbialite inorganically, and organisms adding to the carbonate biologically. Lake Van microbialites resemble the tufa towers of Mono Lake (smaller at 6 m in height), and stromatolites to some degree, although Lake Van microbialites lack the layered structure of stromatolites. They provide an excellent example of the dynamic interweaving of abiological and biological processes.

### **11.10.3 Coccolithophores and Foraminifera: Biologically Controlled Mineralization**

Konhauser (2007) notes: “Calcium carbonate constitutes the largest fraction of known biologically controlled biominerals.”

Coccolithophores, unicellular algae, foraminifera, and protozoa build their shells of calcite and as result remove an immense amount of calcium from the oceans. Their calcified bodies, over the prehistoric past, have built large micrite deposits, such as the chalk deposits of northwestern Europe, which were formed during the Cretaceous. Some

of these deposits can be 0.5 km thick on average and cover large portions of the deep sea. Today, extensive blooms of *Emiliana huxleyi* can be seen from space because this coccolithophore is so abundant. Think of the impact on carbon cycling that such an abundant organism can have. Larger in size (30  $\mu\text{m}$ –1 mm) than the coccolithophores, foraminifera create elaborate calcite shells, which have been useful in reconstructing prior climatic conditions. How do these organisms create such intricate shells? The details of this phenomenon have not been completely discovered, but investigations have revealed an internal vesicle in coccolithophores that controls calcite formation, using calcium ions from the surrounding seawater, which is supersaturated in terms of calcium carbonate. Contrast this active, biology controlled biomineralization with that of photosynthesizing algae that induce biomineralization through their metabolic activities.

### 11.11 SUMMARY

Microorganisms interact with minerals and rocks in a variety of ways, which can involve precipitation or dissolution of minerals. These processes can be active or passive. For example, negatively charged functional groups on microbial cell surfaces can adsorb metal ions, leading to precipitation of minerals. Microbial metabolic activities can change the amount of substances present, such as carbon dioxide, which shifts chemical equilibria, leading to precipitation or dissolution of minerals. Various microorganisms participate in a wide array of reduction–oxidation (redox) reactions, often obtaining energy for their own needs through oxidation. These redox reactions can be extremely important in the generation of ore bodies and the creation of acid mine drainage. Some of these reactions lead to dissolution, or corrosion, and can have negative effects on stone monuments, ship hulls, and water pipes, for example. The creation of caves by the generation of sulfuric acid chemically and microbially is seen in the dramatic, large rooms of caves in the Guadalupe Mountains. Iron and manganese redox reactions lead to the production of magnetite in magnetotactic bacteria, which helps them orient in their environment, and to the production of rock varnish and ferromanganese nodules in various environments. An active discussion is currently underway regarding the role of microorganisms in the latter. Microorganisms, such as diatoms, also utilize geomicrobiological interactions in the formation of silica in their beautiful body structures, while other organisms participate in the formation of carbonates. Stromatolites and travertines appear to form at least partially through the geomicrobiological interactions of microorganisms. Throughout the natural world, we can observe and study the role of microorganisms in the precipitation and dissolution of minerals.

### 11.12 DELVING DEEPER: CRITICAL THINKING QUESTIONS

1. What is the difference between the terms *mineral* and *rock*? Which is more appropriate when talking about geomicrobiological interactions?
2. What are the differences between passive and active biomineralization?
3. How does the microbial cell influence metal binding?
4. Do microorganisms gain or require energy for oxidation and reduction reactions in general?

5. What role do siderophores play in geomicrobiological reactions?
6. How do microorganisms affect the solubility or the liberation of ore metals?
7. What are examples of reactions that release acidity, leading to dissolution of surrounding minerals?
8. If you were investigating the role of microorganisms in the formation of rock varnish, how would you discern abiotic from biotic formation?

## BIBLIOGRAPHIC MATERIAL

### Further Reading

- Banfield JF, Nealson KH, eds. (1997), *Geomicrobiology: Interactions between microbes and minerals*, in *Reviews in Mineralogy*, Vol. 35, Washington, DC: Mineralogical Society of America.
- Bazylinski DA, Schüler D (2009), Biomineralization and assembly of the bacterial magnetosome chain, *Microbe* **4**:124–130.
- Konhauser K (2007), *Introduction to Geomicrobiology*, Malden, MA: Blackwell Publishing.
- Lovley DR (2000), *Environmental Microbe-Metal Interactions*, Washington, DC: ASM Press.
- Lowenstam HA, Weiner S (1989), *On Biomineralization*, New York: Oxford University Press.

### Cited References

- Barton HA, Spear JR, Pace NR (2001), Microbial life in the underworld: Biogenicity in secondary mineral formations, *Geomicrobiol. J.* **18**:359–368.
- Bazylinski DA, Frankel RB, Konhauser KO (2007), Modes of biomineralization of magnetite by microbes, *Geomicrobiol. J.* **24**:465–475.
- Bazylinski DA, Schüler D (2009), Biomineralization and assembly, *Microbe* **4**:124–130.
- Beech IB, Sunner J (2004), Biocorrosion: Towards understanding interactions between biofilms and metals, *Curr. Opin. Biotechnol.* **15**:181–186.
- Boquet E, Boronat A, Ramos-Cormenzana A (1973), Production of calcite (calcium carbonate) crystals by soil bacteria is a general phenomenon, *Nature* **246**:527–529.
- Chafetz HS, Buczynski C (1992), Bacterially induced lithification of microbial mats, *PALAIOS* **7**:277–293.
- Chafetz HS, Folk RL (1984), Travertines: Depositional morphology and the bacterially constructed constituents, *J. Sedimentary Petrol.* **54**:289–316.
- Ehrlich HL (2002), *Geomicrobiology*, 4th ed., New York: Marcel Dekker.
- Engel AS, Stern LA, Bennett PC (2004), Microbial contributions to cave formation: New insights into sulfuric acid speleogenesis, *Geology* **32**:369–372.
- Jagnow DH, Hill CA, Davis DG, DuChene HR, Cunningham KI, Northup DE, Queen JM (2000), History of the sulfuric acid theory of speleogenesis in the Guadalupe Mountains, New Mexico, *J. Cave Karst Studies* **62**:54–59.
- Jones B, Renaut RW (2006), Growth of siliceous spicules in acidic hot springs, Waiotapu geothermal area, North Island, New Zealand, *PALAIOS* **21**:406–423.
- Kempe S, Kazmierczak J, Landmann G, Konuk T, Reimer A, Lipp A (1991), Largest known microbialites discovered in Lake Van, Turkey, *Nature* **349**:605–609.
- Konhauser K (2007), *Introduction to Geomicrobiology*, Malden, MA: Blackwell Publishers.

- Little B, Lee J, Ray R (2007), A review of “green” strategies to prevent or mitigate microbiologically influenced corrosion, *Biofouling* **23**:87–97.
- Lowenstam HA (1981), Minerals formed by organisms, *Science* **211**:1126–1131.
- McConnaughey TA, Whelan JF (1997), Calcification generates protons for nutrient and bicarbonate uptake, *Earth Sci. Rev.* **42**:95–117.
- McPhee J (2011), The little workers of the mining industry, *Sci. Creative Quart.* **6**  
<http://www.scq.ubc.ca/the-little-workers-of-the-mining-industry/>.
- Pedley M (2009), Tufas and travertines of the Mediterranean region: A testing ground for freshwater carbonate concepts and developments, *Sedimentology* **56**:221–246.
- Perry TD, Duckworth OW, McNamara CJ, Martin ST, Mitchell R (2004), Effects of the biologically produced polymer alginic acid on macroscopic and microscopic calcite dissolution rates, *Environ. Sci. Technol.* **38**:3040–3046.
- Planavsky N, Ginsburg RN (2009), Taphonomy of modern marine Bahamian microbialites, *PALAIOS* **24**:5–17.
- Rawlings DE, Johnson DB (2007), The microbiology of biomining: Development and optimization of mineral-oxidizing microbial consortia, *Microbiology* **153**:315–324.
- Reid RP, Visscher PT, Decho AW, Stolz JF, Bebout BM, Dupraz D, Macintyre IG, Paerl HW, Pinckney JL, Prufert-Bebout L, Steppe TF, DesMarais DJ (2000), The role of microbes in accretion, lamination and early lithification of modern marine stromatolites, *Nature* **406**:989–992.
- Riding R (1991), Classification of microbial carbonates, in Riding R, ed., *Calcareous Algae and Stromatolites*, Berlin: Springer-Verlag, pp. 21–51.
- Riding R (2000), Microbial carbonates: The geologic record of calcified bacterial-algal mats and biofilms, *Sedimentology* **47**:179–214.
- Southam G, Saunders JA (2005), The geomicrobiology of ore deposits, *Econ. Geol.* **100**:1067–1084.
- Tebo BM, Bargar JR, Clement BG, Dick GJ, Murray KJ, Parker D, Verity R, Webb SM (2004), Biogenic manganese oxides: Properties and mechanisms of formation, *Annu. Rev. Earth Planet. Sci.* **32**:287–328.
- Van Hamme JD, Singh A, Ward OP (2003), Recent advances in petroleum microbiology, *Microbiol. Molec. Biol. Rev.* **67**:503–549.
- Walter MR (1976), Introduction, in Walter MR, ed., *Stromatolites. Developments in Sedimentology*, Vol. **20**, Amsterdam: Elsevier, pp. 1–7.

### Internet Sources

<http://www.tandf.co.uk/journals/tf/01490451.html>: *Geomicrobiol. J.*

## DECOMPOSITION OF NATURAL COMPOUNDS

---

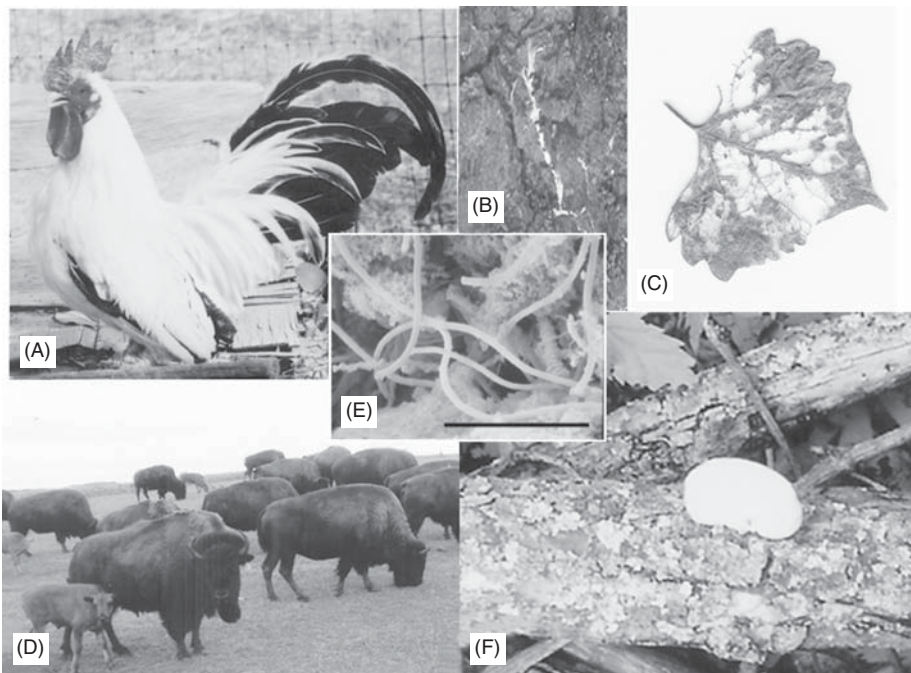
### 12.1 CENTRAL THEMES

- Microorganisms are capable of degrading materials that plants and animals produce.
- Specific enzymes produced by microorganisms are required to decompose plant structural materials such as cellulose, pectin, and lignin.
- Chitin, collagen, keratin, and silk are fibrous proteins of animals that are slowly decomposed by microorganisms.
- Fermented foods result from bacteria in the environment initiating decomposition, but production of organic acid terminates growth of all bacteria and the food is preserved.
- Ethanol production by yeast conversion of starch, sugarcane, and agricultural grasses involves specific enzymes for decomposition activity.
- Algal production of H<sub>2</sub>, methane production from anaerobic microbial digestion, and oil production by algae are important for our expanding use of biofuels.
- Carbon cycling is an important component in composting of plant debris and sewage treatment.
- Microbes have a negative impact on humans by contributing to the “sick building” syndrome and defacing of historic art objects.



## 12.2 INTRODUCTION

While we may regard decomposition as a naturally occurring event, to the microorganisms it is an important process contributing to their livelihood. Bacteria and fungi are important in decomposition of biological material, and without these microorganisms there would be an accumulation of dead plants and animals. Louis Pasteur initially recognized the importance of microorganisms in applied sciences and decomposition activity. In one of his addresses to the scientific community, Pasteur proclaimed: “Messieurs, c’est les microbes qui auront le dernier mot.” As discussed in Chapter 10, decomposition of organic material is required for biogeochemical cycling of carbon. Figure 12.1 highlights several different structural materials that require decomposition by bacteria or fungi through the use of a wide spectrum of enzymes (Sasikala 1996). Persistence of microorganisms in the environment is attributed to their metabolic ability and, therefore, microorganisms have evolved to use a diversity of biological materials for energy. Some



**Figure 12.1.** Examples of biological material that are decomposed by microorganisms: (A) feathers, beak, feet, and comb of this black-tailed white Japanese bantam rooster must be decomposed as well as muscle and other soft tissues; (B) thread-like growth of white rot fungi growing on the bottom side of a log; (C) differential degradation of tissues in a cottonwood leaf indicating structural material is more recalcitrant to enzymatic digestion; (D) the horns, hooves, and hide of Great Plains Bison represent biostructures that are decomposed by unique microbial processes; (E) decomposition in nature is attributed to mixed cultures of bacteria (scale bar 25  $\mu\text{m}$ ); (F) initial digestion of a fallen branch is attributed to bracket fungi; also note lichen growing on the bark of the branch [photograph (A) supplied by Gordon Johnson; other images provided by Larry Barton]. See insert for color representation.

of the more common plant and animal structural polymers are presented, including the following biodegradable plant and animal polymers:

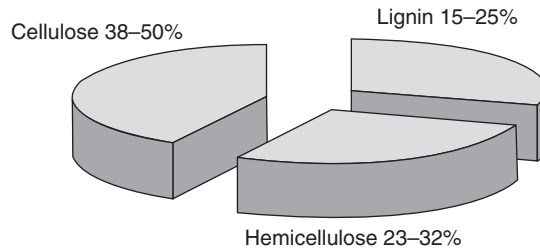
- *Cellulose*—a linear polymer of glucose with  $\beta$ -1,4-glucosidic bonds forming a crystalline unit
- *Chitin*—a linear polymer of *N*-acetylglucosamine linked by  $\beta$ -1,4-glucosidic bonds in the exoskeleton of invertebrates and insects and in the cell walls of fungi
- *Cutin*—polyesters of hydroxyl and epoxy fatty acids that serve as barriers on aerial plant parts
- *Dextran*—polymer of glucose with  $\alpha$ -1,4-glucosidic bond
- *Hemicellulose*—matrix polysaccharides binding to cellulose in cell walls of plants
- *Inulin*—polymer of fructose with  $\alpha$ -1,4-glucosidic bond found in tubers of Jerusalem artichokes
- *Keratin*—a structural protein found in hooves, wool, scales, and feathers that is difficult to degrade because of its unique molecular organization
- *Lignin*—a highly branched phenolic polymer between cellulose microfibrils in cell walls of plants
- *Pectin*—a gel-forming polysaccharide that can be removed by extraction of hot water and consists of galacturonic acid, rhamnose, arabinose, and galactose
- *Polyesters*—poly- $\beta$ -hydroxybutyrate and other polyhydroxyalkanoates in bacteria and algae
- *Starch and glycogen*—linear  $\alpha$ -1,4-glucosidic bond and branched  $\alpha$ -1,6-glucosidic bond polymers of glucose with glycogen more highly branched than starch
- *Suberin*—a polymer of aromatics and polyesters that serve as barriers on underground plant structures
- *Xanthan*—a cellulose-type mainchain and trisaccharide chains containing glucuronic acid

This chapter explores decomposition of natural compounds and includes the impact that these microbial activities may have on global populations.

### 12.3 DECOMPOSITION OF WOOD

The biological decomposition of wood is extremely important in carbon cycling. Some have proposed that the atmosphere would run out of carbon dioxide for photosynthesis if there would be no decomposition of wood for 20 years. Decomposition of wood has long been observed; however, it was not until 1878 that Robert Hartig demonstrated that fungi were responsible for this activity, and shortly thereafter Oshima provided evidence that wood polymers were digested by insects. The general composition of polymers in wood is given in Figure 12.2.

The wood cells near the periphery of the branch or log are referred to as *sapwood* because these are living cells that carry on biological activities, including respiration. Because of active defense activities, uncut sapwood is markedly resistant to microbial decomposition. If fresh-cut logs are collected, microorganisms from the wood surface will quickly grow on the sugars, amino acids, and proteins present in the cytoplasm of



**Figure 12.2.** Distribution of major polysaccharides present in wood.

the sapwood cells. Growth of *Penicillium* spp. and common surface molds can result in discolorations of wood as the mycelium penetrates the wood. When fresh-cut lumber is properly aerated, the stored nutrient reserves in the cytoplasm of sapwood cells are consumed by respiratory activity of the wood parenchyma cells, and growth of surface fungi or bacteria is not a problem. If fresh-cut wood is immediately kiln-dried, the parenchyma cells in the sapwood are killed, and the nutrient reserves remains. When this wood is exposed to water, fungi and bacteria grow on the nutrient reserves and wood decomposition results. The heartwood cells will have lost their cytoplasmic constituents and are therefore somewhat resistant to microbial decomposition. The heartwood of cypress, cedar, and osage-orange trees is highly resistant to microbial decomposition because of the high levels of phenols, terpenes, and alkaloids that inhibit the growth of fungi, bacteria, and insects. Decomposition of softwood is a continuous activity found along rivers and uncultivated fields (Figure 12.3). Rates of wood decomposition are influenced by the species of trees, climate, and activity of microorganisms present.

Lignin is a major deterrent in the decomposition of wood because lignin forms a sheath-like layer that protects cellulose and hemicellulose from enzymatic digestion.

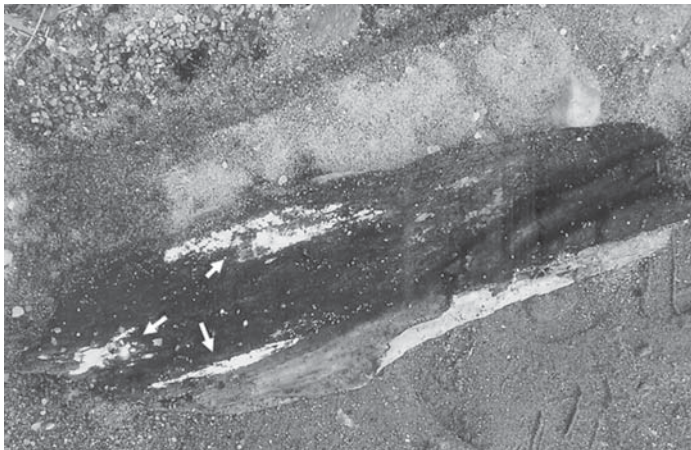


**Figure 12.3.** Natural degradation of cottonwood branches and other forest products (photograph by Larry Barton). See insert for color representation.

Insects or borers create small holes in the wood and enable microorganisms to penetrate lignin. Ambrosia beetles, carpenter bees, and carpenter ants do not ingest wood but disrupt the structural integrity by boring holes or tunnels into wood. Termites, the beetle *Stromatium barbatum*, and the marine borer *Bankia setacea* use microorganisms in their gut to degrade cellulose and hemicellulose. A second mechanism of overcoming the protective effect of lignin is the direct enzymatic digestion by fungi and bacteria. Microbial decomposition of wood is attributed to extracellular enzymes, and their production is a result of induction by soluble, low-molecular-weight sugars. Three groups of fungi contribute to enzymatic degradation of wood: white rot fungi (see Figure 12.4), brown rot fungi, and the soft rot fungi. It has been estimated that about 1700 species of fungi in North America contribute to white or brown wood rot and most of the fungi are members of the class Basidiomycetes. The fungal growth penetrates the wood, and the color of the mycelium in the wood is responsible for the designation of brown or white rot. With soft rot, fungal growth is along the area where the wood is wet and decay is initially at the surface but moves inward as the mycelium penetrates the wood. Although there may be color changes in the decaying wood, the softening of wood in the early stages of decay is the hallmark characteristic of this type of fungal activity. Streptomyces and other soil bacteria are also implicated in soft rot of wood.

#### 12.4 DIGESTION OF PLANT CELL WALL STRUCTURES

The primary cell wall of plants consists of cellulose, hemicellulose, pectin, and a small amount of protein. Cellulose provides the rigidity to support the plant structures, while hemicellulose and pectin form a matrix around the cellulose fibrils. In many cultures, houses were constructed from reeds (Figure 12.5), and these structures required continuous maintenance because microbes digested the plant material. A model suggesting the architecture of the primary cell wall of plants is shown in Figure 12.6.

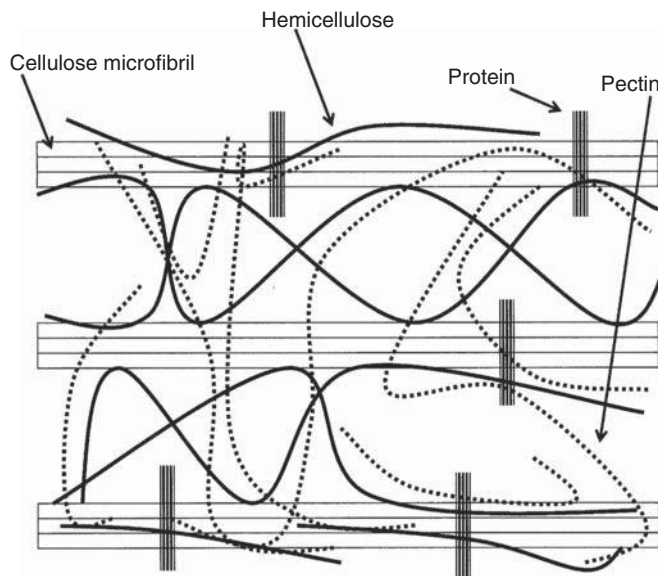


**Figure 12.4.** Decomposition of log by fungi; white rot fungi are growing at the log–soil interface, where moisture collects and fungi are seen white patches (at arrows) on the underside of the log (photograph by Larry Barton). See insert for color representation.





**Figure 12.5.** Reconstruction of a reed house located at a nature center near Spicer, Minnesota (photograph by Larry Barton).



**Figure 12.6.** Model of plant cell wall structure.

Hemicellulose binds the cellulose microfibrils into a cohesive unit, while pectin forms a gel phase that contributes to the porosity of the cell wall and prevents collapse of the cellulose–hemicellulose framework. Lignin is added as secondary metabolism to the plant cell walls and contributes to mechanical stability of the plant tissues; the quantity of lignocellulosic materials may vary with the plant type as indicated in Table 12.1 (Ghosh and Singh 1993). The sequence of events in the degradation of fresh plant cell wall material is as follows: (1) protopectinase releases pectin from plant cell wall material,

TABLE 12.1. Lignocellulosic Material in Selected Plant Biomass

Material	Dry-Weight Composition as a Percentage		
	Cellulose	Hemicellulose	Lignin
Wheat straw	30	24	18
Red maple	39	33	23
Pine	41	10	27
Corncobs	42	39	14
Aspen	50	28	15

(2) pectin is degraded by pectinases, and (3) hemicellulose and lignin are degraded and the exposed cellulose is hydrolyzed by enzymes.

#### 12.4.1 Protopectinase and Pectinase Activities

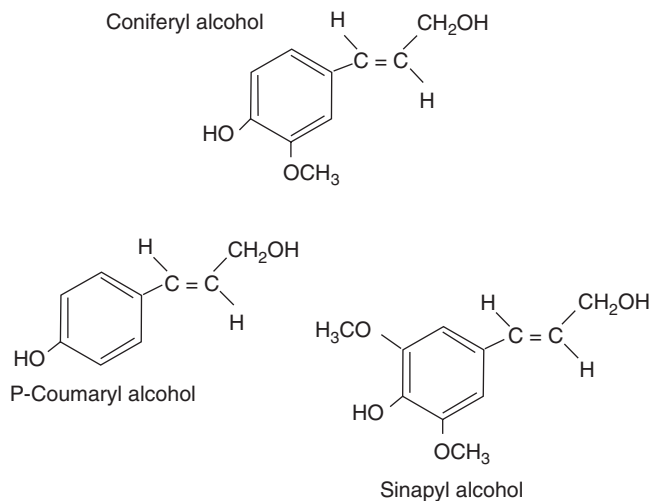
The release of pectin from the cell wall is accomplished by protopectinases, and this action results in separation of cells. In terms of hydrolytic action, there are two types of protopectinases: an *A-type enzyme*, releases pectin in soluble low-molecular-weight segments; and a *B-type enzyme*, which releases high-molecular-weight segments that have extensive polymerization. Protopectinases are produced by *Kluyveromyces fragilis* (yeast), *Aspergillus niger*, and *Bacillus subtilis* (Sakai et al. 1993).

*Pectin*, found in cell walls of plants, is a linear polymer of galacturonic acid bonded by  $\alpha$ -1,4 sugar linkages, and some of the carboxyl groups of the sugar are esterified to methanol. In some cases, pectin has short sidechains of rhamnose, arabinose, or other neutral sugars. Because pectin may vary with cell type and plant species, the molecular mass of pectin ranges from 10,000 to 400,000 (Sakai et al. 1993). In the cell wall, pectin forms an interlocking gel that is attached to proteins and other structural components of the cell wall. The name commonly used to refer to enzymes that degrade pectin is *pectinase*, and these enzymes are primarily of the polygalacturonidase and esterase types. Pectinases are produced by various soil fungi and various bacteria, especially those that are plant pathogens. Commercially there is an application using pectinases to remove turbidity in apple and other juices. It is of historical interest that *Clostridium* and *Bacillus* were used in a “retting” process to decompose pectin in flax straw with the release of textile fibers used in production of linen.

#### 12.4.2 Microbial Decomposition of Lignin

One of the most abundant organic materials in plants is lignin, which in woody plants can account for 15–25% of organic substances present. Lignin is a polymer consisting of three basic alcohols: sinapyl, coniferyl, and coumaryl alcohols (see Figure 12.7). These three alcohols are linked together to form a large three-dimensional matrix that is covalently bonded to cellulose and other polysaccharides in the plant cell wall. Lignin is not composed of a simple repeating of monomers, as is the case for cellulose, starch, pectin, or inulin, but covalent attachments of the three alcohols appear to have considerable randomness. Additionally, there appears to be control over production of the alcohols by plants with beechwood lignin containing coniferyl alcohol, sinapyl alcohol, and coumaryl





**Figure 12.7.** Examples of phenolic alcohols present in lignin.

alcohol at a ratio of 100 : 70 : 7, respectively. This ratio of alcohols in lignin varies with plant species, and lignin from gymnosperms is low in sinapyl alcohol moieties.

The structure of lignin is highly resistant to decomposition because the random bond formation between the three alcohols would require a large number of enzymes to recognize a specific bond. *Ligninase* is the general name given to enzymes that break the covalent bonds constituting the lignin matrix. While various soil microorganisms can degrade lignin, the best studied lininolytic enzymes are produced by *Phanerochaete chrysosporium* (a white rot fungus), *Streptomyces cyaneus*, and *Thermomonospora mesophila*.

Degradation of lignin is attributed to lignin peroxidase, laccase, and Mn peroxidase activities. Degradation of lignin by these enzymes is attributed to free-radical formation, and the subsequent attack of lignin is less specific than that of hydrolytic enzymes for cellulose or starch degradation. Lignin peroxidase and laccase catalyze one-electron oxidations of phenolic compounds that produce phenoxy radicals and finally removal of the methoxy ( $-\text{OCH}_3$ ) group. The enzyme Mn peroxidase oxidizes  $\text{Mn}^{2+}$  to  $\text{Mn}^{3+}$ , which is stabilized by oxalic acid in the cell wall region until it reacts oxidatively with organic substrates. Since enzymology of lignin degradation requires molecular oxygen, lignin decay is not associated with anaerobic environments.

### 12.4.3 Degradation of Hemicellulose

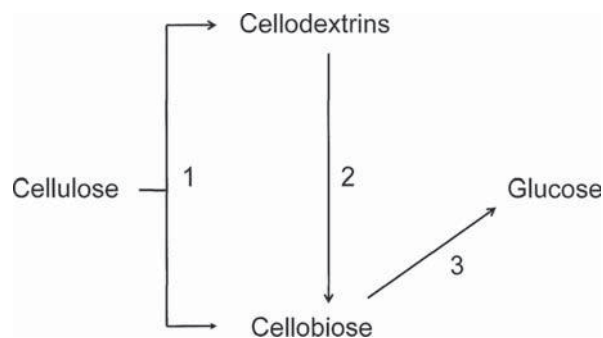
Hemicelluloses are polymeric sugar structures that account for about 25% of the primary cell wall of plants. These flexible polymers bind to cellulose microfibrils with a composition that varies with plant species and cell type. Sugars present in hemicelluloses include xylose, glucose, mannose, arabinose, galactose, and methylglucuronic acid (Mishra and Singh 1993). A major component in hemicelluloses are xylans (polymers of the pentose xylose), and the decomposition of xylans occurs by action of *endo- $\beta$ -1,4-xylanases* or *exo- $\beta$ -1,4-xylanases*. Release of other sugars from hemicellulose requires enzymes specific for bonds linking the various sugars. Bacteria and fungi that hydrolyze the various bonds in hemicellulose are broadly found in the environment. Pentoses or hexoses

released from enzymatic hydrolysis of hemicellulose are consumed by microorganisms in the environment.

#### 12.4.4 Enzymatic Degradation of Cellulose

Cellulose synthesis by plants accounts for about  $4 \times 10^7$  tons annually, making it the most abundant carbohydrate polymer on Earth. Cellulose is a linear polymer consisting of 8000–12,000 glucose units bonded together by a  $\beta$ -1,4-glycosidic linkage. Microorganisms produce several different cellulases, including *endo*-1,4- $\beta$ -glucanase, *exo*-1,4- $\beta$ -glucanase, and 1,4- $\beta$ -glucanase with enzymatic degradation as shown in Figure 12.8 (Lynd et al. 2002; Singh and Hayashi 1995). The best characterized systems for cellulose hydrolysis are with *Phanerochaete chrysosporium* (a white rot fungus), *Poria placenta* (a brown rot fungus), *Trichoderma reesei* (a soft rot fungus), *Cellulomonas fimi* (an aerobic bacterium), *Clostridium thermocellum* (an anaerobic bacterium), and *Thermoactinomyces curvata* (an actinomycete). Cellulose hydrolysis by *P. chrysosporium* and *T. reesei* is attributed to multiple forms of *endo*-1,4- $\beta$ -glucanases, *exo*-1,4- $\beta$ -glucanases, and 1,4- $\beta$ -glucanases, while *P. placenta* produces only *endo*-1,4- $\beta$ -glucanases and 1,4- $\beta$ -glucanases. Generally cellulases produced by fungi are extracellular enzymes and are not bound to the mycelium. Cellulases produced by archaea and bacteria may be either free in the extracellular fluid or clustered in structures on the cell surface in a structure referred to as a *cellulosome*.

Bacterial cellulosomes attach to insoluble cellulose substrates and facilitate the decomposition of cellulose for the benefit of the bacterium producing the cellulosome. The cellulosome contains numerous enzymes for cellulose, hemicellulose, and hydrolysis of other carbohydrate polymers with at least 15 enzymes in the cellulosome of *Ruminococcus albus*, over 90 cellulosomal enzymes produced by *Acetivibrio cellulolyticus*, and 50–60 enzymes in the cellulosome of *Clostridium thermocellum* and *C. acetobutylicum* (Doi 2008). In contrast, the thermophilic bacterium *Anaerocellum thermophilum* does not have cellulosomes but digests cellulose in switchgrass by free extracellular enzymes (Yang et al., 2009). There is considerable interest in applying molecular biology for genetic engineering to transform yeast to grow on cellulosic material for the production of alcohol (Demain et al. 2005).



**Figure 12.8.** Participation of fungal enzymes in hydrolysis of cellulose: (1) *exo*-1,4- $\beta$ -glucanase; (2) *endo*-1,4- $\beta$ -glucanase; (3) 1,4- $\beta$ -glucanase.

## 12.5 STARCH HYDROLYSIS

A common carbohydrate storage compound in plants is starch, which is a polymer of glucose consisting of linear and branched segments (see Figure 12.9). Linear attachments of glucose is by  $\alpha$ -1,4-glucosidic bonds, and formation of the branch is attributed to glucose attached by an  $\alpha$ -1,6-glucosidic linkage. Many soil bacteria and fungi secrete  $\alpha$ -amylase,  $\alpha$ -1,6-glucosidase, and glucoamylase, which are capable of hydrolyzing starch to low-molecular-weight molecules. The  $\alpha$ -amylase attacks starch at the nonreducing end and releases maltose, while  $\alpha$ -1,6-glucosidase hydrolyzes only the  $\alpha$ -1,6-glucosidic linkage. Following extensive digestion of starch by  $\alpha$ -amylase, a limit dextrin is produced where branches are terminated by a glucose unit attached to the linear segment by the  $\alpha$ -1,6-glucosidic bond. Filamentous fungi such as *Aspergillus niger* may produce  $\alpha$ -amylase,  $\alpha$ -1,6-glucosidase, and glucoamylase. Glucoamylase hydrolyzes the  $\alpha$ -1,6-glucosidic linkage and  $\alpha$ -1,4-glucosidic linkage with equal efficiency. These extracellular enzymes work synergistically in the environment to rapidly degrade starch. *Glucoamylases* are carbohydrases that can attack numerous substrates in addition to starch. Glucoamylases will digest glycogen, a reserve carbohydrate polymer of animals, and polyglucose storage molecules in bacteria to glucose. *Clostridium* spp. are some of the few bacteria that produce glucoamylase, and this is significant in the environment because fungi do not grow in the anaerobic zones where clostridia flourish.

## 12.6 INULIN HYDROLYSIS

Inulin is the storage material found in tubers of Jerusalem artichoke, chicory, and dandelion roots (Vandamme and Derycke 1983). Inulin is a natural plant product consisting of a polyfructose molecule with a terminal glucose unit. The size of the molecule may vary with the plant species and a molecular weight of 3500–5500 is commonly produced. Inulinase is the enzyme that hydrolyzes the  $\beta$ -2,6-fructose bonds in linear polymer and  $\beta$ -2,1-fructose bond at branch points of the inulin structure. Inulinase is secreted by many different microorganisms, the most common of which are *Aspergillus niger*,

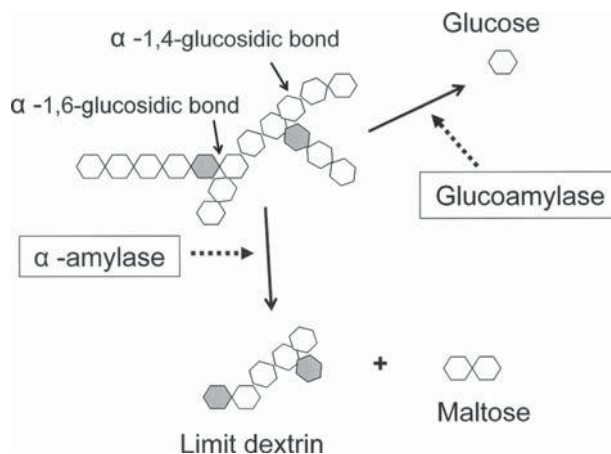
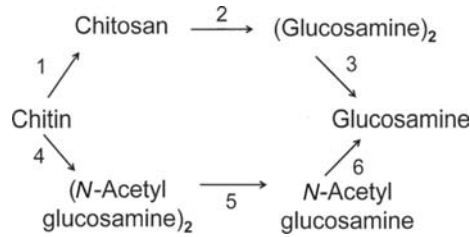


Figure 12.9. Model of starch molecule with enzymatic digestion.



**Figure 12.10.** Figure indicating destruction of chitin by enzymes: (1) chitin deacetylase; (2) chitosanase; (3) glucosaminidase; (4) chitinase; (5) *N*-acetylglucosaminidase; (6) deacetylase.

*Kluyveromyces fragilis*, and *Arthrobacter ureafaciens*, which are molds, yeast, and bacteria, respectively. There is the potential for use of inulin as a starting material for high-fructose syrups and as a fermentation substrate for ethanol production.

## 12.7 DECOMPOSITION OF DIVERSE BIOPOLYMERS INCLUDING ANIMAL FIBROUS PROTEINS

Various fibrous proteins found in animals are decomposed slowly in soil or aquatic environments by fungi and bacteria. Chitin, keratin, and silk have a molecular structure markedly distinct from that of soluble proteins, and this fibrous structure requires unique enzymes to degrade the fiber. Additionally, the interaction of insoluble structure of fibrous proteins with soluble enzymes contributes to the difficulty for their enzymatic hydrolysis. When an animal dies in the environment, the flesh and viscera are quickly decomposed by bacteria, but the skin, hair, and bones persist for some time. Fibrous proteins are difficult to decompose, and several of these proteins are discussed.

### 12.7.1 Chitin Digestion

*Chitin* is a polymer of *N*-acetylglucosamine found in the cell walls of fungi, exoskeleton of invertebrates, and insects. The annual production of chitin is about 7 tons (Gooday 1990). The most common is  $\alpha$ -chitin with polymeric chains arranged in antiparallel configuration that are held together by hydrogen bonds to produce a relative rigid sheet. A less common form is  $\beta$ -chitin, where the polymeric chains are arranged in parallel without hydrogen bonds. There is considerable range in the amount of chitin produced in marine environments. In the Atlantic Ocean about 4.5 mg of chitin is produced per square meter annually by krill, and 1.5 g chitin is produced annually per square meter by lobsters in waters off of South Africa. The pathway and enzymes involved in degradation of chitin are shown in Figure 12.10. There are many examples of microorganisms capable of degrading chitin with the production of chitosan, which is a deacylated chitin. Chitinolytic bacteria include *Cytophaga*, *Vibrio*, and *Streptomyces*, while examples of fungi-digesting chitin include *Mortierella*, *Trichoderma*, and *Penicillium*.

### 12.7.2 Decomposition of Keratin

The structural proteins of hair, horns, hooves, and wool are  $\alpha$ -keratin. The individual proteins are long molecules with an  $\alpha$ -helix. As indicated in Table 12.2, wool keratin

TABLE 12.2. Amino Acid Composition<sup>a</sup> of Keratin, Collagen, and Fibroin

Amino Acid	Bovine Tendon (Collagen)	Silk (Fibroin)	Wool ( $\alpha$ -Keratin)
Alanine	12.0	29.4	5.0
Arginine	5.0	0.5	7.2
Aspartic acid+asparagine	4.5	1.3	6.0
Cysteine	0	0	11.2
Glutamic acid+glutamine	7.7	1.0	12.1
Glycine	32.7	44.6	8.1
Histidine	0.3	0.2	0.7
Isoleucine	0.9	0.7	2.8
Leucine	2.1	0.5	6.9
Lysine	3.7	0.3	2.3
Methionine	0.7	0	0.5
Phenalanine	1.2	0.5	2.5
Proline	22.1	0.3	7.5
Serine	3.4	12.2	10.2
Threonine	1.6	0.9	6.5
Tryptophan	0	0.2	1.2
Tyrosine	0.4	5.2	4.2
Valine	1.8	2.2	5.1

<sup>a</sup>Values are given in mole percent (mol%).

contains high levels of cysteine for the formation of disulfide crossbridges. The proteins in feathers, skin, claws, beaks, and scales of birds and reptiles are  $\beta$ -keratin because these proteins have a  $\beta$ -sheet structure. The  $\alpha$ -keratin and  $\beta$ -keratin proteins require special enzymes for hydrolysis, and because of their compact molecular arrangement, they decay slowly. Keratinolytic enzymes are similar to serine metalloproteases and are produced by many pathogenic dermatophytes and mesophilic bacteria as well as numerous environmental microorganisms. Thermophilic bacteria and *Bacillus* species with keratinolytic activity are being considered for industrial processing systems.

The quantity of keratin proteins from poultry processing plants primarily in the form of feathers (Figure 12.11) is estimated to exceed 10,000 tons annually (Suzuki et al. 2006). Feathers are difficult to degrade because the proteins are often covered by a fine powder or oils from the birds to make the feathers nonwettable, and the  $\beta$ -sheet structure is a challenge for many enzymes. New feather-degrading bacteria are being isolated to find organisms that would be optimum for decomposition of bird wastes (Riffel and Brandelli 2006). Additionally, pigments attached to feathers may influence the rate of keratin decomposition. Generally the yellow-red feathers are attributed to carotenoids; brown-black feathers, to melanins; and green feathers, to porphyrins. The bright red feathers of macaw parrots are attributed to a special chemical referred to as *polyenal lipochrome*. There is a suggestion that bacteria may have a role in evolution of bird plumage coloration (Grande et al. 2004) because melanin-containing feathers are degraded before carotenoid-containing or unpigmented feathers. This would be especially important if feathers were degraded while attached to the bird and not just after they are released.

### 12.7.3 Fibroin Decomposition

Another fibrous protein is *fibroin*, which contains lengthy regions of antiparallel  $\beta$  sheet with fibers fitting close together to produce a strong fiber. Silk spun by silkworms



**Figure 12.11.** Bird feathers present a challenge for natural decomposition because of the unique chemical structure of the feather; as shown here, chicken farms will accumulate large quantities of feathers (photograph by Larry Barton). See insert for color representation.

(Figure 12.12) is an example of proteinaceous material with long stretches of  $\beta$ -sheet protein. As shown in Table 12.2, silk contains a great amount of glycine (Gly), alanine (Ala), and serine (Ser). Characteristic of the silk fiber is the following protein chain that accounts for a tight interaction between peptide segments in the  $\beta$ -sheet structure:



Interspersed between the  $\beta$  sheets are folded proteins regions attributed to relatively bulky amino acids, and these folded regions may contribute to the stretchiness of the silk fiber. The number of non- $\beta$ -sheet structure in a silk fiber appears to be characteristic of the specific strain of silkworm. Enzymes that hydrolyze silk include the serine protease referred to as *elastin* and proteases produced by *Bacillus* or *Aspergillus*. The folded segments of silk fibroin are initially degraded, while the  $\beta$  sheets are more resistant to enzyme hydrolysis.

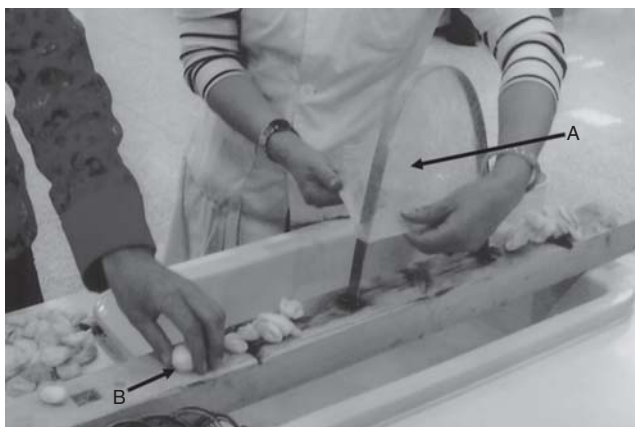
While the distribution of silk production by worms is limited in the environment, silk production by spiders is found worldwide. Webs from spiders may vary from ornate by orb weavers (see Figure 12.13) to mat-like appearance produced by various spiders.

While spiderwebs persist when suspended above the ground, these natural fibers are readily digested by microorganisms in the soil. There are at least seven different types of silk produced by spiders, and each has distinctive mechanical properties (Rising et al. 2005). Silk from mulberry silkworms has a high concentration of serine, glycine, and alanine, while in spider silk these amino acids are in low concentration.

#### 12.7.4 Collagen Breakdown

The most abundant protein in vertebrates is collagen because it is associated with various connective tissues including tendons and skin. The amino acid composition of collagen is given in Table 12.2. Because collagen has a sequence of (glycine–any amino acid–proline) with about 40% of proline as hydroxyproline the protein has a unique structure.





**Figure 12.12.** Protein making up silk has a unique structure, and decomposition of silk is distinct from other animal proteins; silk thread is taken from the cocoon by a special process by workers in the Silk Factory, Beijing, China (photograph by Larry Barton). See insert for color representation.



**Figure 12.13.** Spiderweb by orb-weaving garden spiders is an example of another form of silk (photograph by Larry Barton).

About 14% of the lysine residues are hydroxylysine and these hydroxylysines are involved in crosslinking collagen fibers together. The enzyme, known as *collagenase*, is produced by various aerobic and anaerobic bacteria in the environment as well as terrestrial fungi (Watanabe 2004). Collagen degradation by anaerobic oral bacteria can contribute to tooth loss in individuals with poor hygiene.

## 12.8 ECOLOGY OF FERMENTED FOODS

Throughout time fermentation has been important for preservation of food, and although the type of food varies, the general theme is the conversion of fermentable sugars to high levels of lactic acid, which results in a pH of 4 and serves as a preservative (Shetty et al. 2006). In most cases, the microorganisms involved come from the environment and there is an ecological succession of microorganisms as the fermentation progresses. Increased control of end product was attributed to starter cultures instead of the bacteria or yeast from the environment. Initially starter cultures were passed from family to family, much as the culture for sourdough bread is today. A further control of the fermentation process came with the use of pure cultures of bacteria and yeast. A partial list of fermented milk products is given in Table 12.3. Since many enteric bacteria and clostridia produce a mixture of organic acids that give the food a bad flavor, it is desirable to use bacteria of the lactobacillus group because they produce only lactic acid as the end product of fermentation. In bioproduction of vinegar, fruit juice is fermented to ethanol by yeast and the ethanol is oxidized to acetic acid by bacteria. The high acidity in foods attributed to lactic acid or acetic acid is beneficial because it inhibits growth of bacteria from the environment. Ethanol is an excellent inhibitor of bacterial growth, and ethanol production by yeast fermentation is the objective in many of the beverages (Table 12.4). A partial listing of fermented foods includes the following:

- *Vegetables and fruits*—cabbage, beetroot, radish, apples, cucumbers, mango, and olives
- *Meats*—sausage and fish
- *Dairy products*—yogurt, Bulgarian milk, and cheeses
- *Beverages*—coffee, cocoa, beer, wine, and fermented fruit juices
- *Condiments*—soy sauce and Tabasco sauce

The production of cheese from milk products was carried from Europe to America. There are several hundred types of cheese, and the characteristics of the product are dependent on the biochemical activities of the specific microorganisms (Law 1999). The first step in cheese production is addition of rennin, an enzyme from calf stomach, and the desired culture of lactobacillus to milk. After fermentation of milk, the solid curd is separated from the liquid whey and pressed into a desired shape. The curd is processed to remove water, and salt is added to prevent growth of undesirable microorganisms. The curd may be consumed as cottage cheese or may be mixed with cream to produce creamed cheese. For hard cheeses (e.g., cheddar, Swiss, Pate, or Reggiano) bacteria are introduced into milk before curd production; for soft cheeses (e.g., Limburger, Brie, or Camembert), specific strains of bacteria distributed on the surface of the curd mass. In the case of the soft cheese, enzymes of the bacteria penetrate the cheese to partly liquify the cheese. With semisolid cheeses such as Roquefort or blue cheese, *Penicillium roqueforti* is inoculated into the curd, and incubation occurs for several months under cool conditions. Specific strains of microorganisms account for the flavor and texture of the final cheese product. For example, fungal growth contributes to the characteristic blue veins of Roquefort cheese; *Propionibacter shermani* produces carbon dioxide, which accounts for the holes in Swiss cheese; and *Brevibacterium linens* produces the strong odor characteristic of Limburger cheese.

TABLE 12.3. Bacterial Fermentation of Milk

Product	Process
Acidophilus milk	<i>Lactobacillus acidophilus</i> is inoculated into sterilized milk, and the milk is incubated until acidity develops to 0.6% lactic acid; consumed for probiotic benefit
Bulgarian milk	Milk is inoculated with <i>Lactobacillus bulgaricus</i> , and the culture is incubated to develop 1% lactic acid; this milk has no aroma
Kefir	Cow, goat, or sheep milk is a product of mixed lactic acid and alcoholic fermentation; milk is inoculated with <i>Streptococcus lactis</i> and <i>Lactobacillus bulgaricus</i> to produce 1% lactic acid and lactose-fermenting yeast to produce 0.5–1% ethanol.
Kumiss	Fermentation is similar to that of kefir except mare's milk is used.
Yogurt	Fermentation of concentrated milk by <i>Streptococcus thermophilus</i> and <i>L. bulgaricus</i> ; fruit jam is added to yogurt custard to assist in preservation; in some regions of the world, yogurt is diluted with water to produce a desired drink

TABLE 12.4. Examples of Fermented Plant Materials Used for Beverage and Condiment Production

Product	Process and Characteristics
Beer	Fermentation of malted grains using <i>Saccharomyces</i> spp. to produce 3.5–5% ethanol; important variables are source of ingredients, type of yeast, and brewing procedures
Cocoa	Native yeast from the environment ferment the sugar-rich mucilage layer on the cocoa bean; in addition to alcohol production, bacterial fermentation results in lactic acid production; heat from the 4-day fermentation increases the temperature to ~50°C, which results in destruction of the bean germ and initiates changes in the bean to give the desired flavor and chocolate color; aerobic bacteria oxidize the ethanol to acetic acid with a resulting pH of 4; after drying the cocoa beans are roasted and ground
Coffee	Coffee beans have a mucilage coat consisting of pectin, glucose, fructose, sucrose, and cellulose; fermentation for 36 h removes the mucilage, but extended fermentation results in undesirable production of lactic, acetic, and propionic acids
Tea	Leaves of tea plants undergo enzymatic degradation, which is referred to as <i>fermentation</i> ; to prevent or stop enzymatic digestion, leaves are heated; teas may be nonfermented (green tea), lightly fermented (jasmine and Pouchong teas), or heavily fermented (black and Oolong teas)
Wine	To produce wine, grape and other fruit juices are fermented to produce 6–15% ethanol; for red wines, grapes with skins are fermented, while for white wines, grape juice is fermented; very little sugar is left after fermentation for dry wines, but for sweet wines sugar remains after fermentation
Soy sauce	Roasted grain, soybeans, and salt are fermented by yeast, <i>Aspergillus oryzae</i> , and other related microorganisms to produce the distinctive taste
Tabasco sauce	Tabasco peppers are fermented in oak barrels for 3–4 years before the desired color and taste are obtained; specifics of the fermentation process are unavailable

## 12.9 ECOLOGY OF BIOENERGY PRODUCTION

There is a growing interest in using microorganisms for production of biofuels, and these are listed in Table 12.5. Butanol production by fermentation of corn by *Clostridium acetobutylicum* (Ezeji and Blaschek 2008) was an important process for biosolvent production but is not envisioned to challenge ethanol production in the energy market. Another potential bioenergy process is the conversion of synthesis gas (CO, H<sub>2</sub>, and CO<sub>2</sub>) to ethanol and methane by various anaerobic bacteria (Tanner 2008). While methanol production from biomass and coal is a useful technology used in several countries, there is some consideration for using methanogenic bacteria to produce methanol (Xin et al. 2004). Microorganisms are also being explored for enhanced oil recovery from existing wells, recovery of oil from tar sands, desulfurization of coal and oil, and establishment of microbial fuel cells.

### *Microbial Spotlight*

**JOSEPH M. SUFLITA**



Even a routine job can change your view of the world and your place in it. Just after his undergraduate studies, Joe Suflita, now of the University of Oklahoma, obtained a technician job doing analyses of water samples. Joe noticed

that one of the water samples he was analyzing smelled like gasoline, and it was from a gas station. Joe noted, "Surely they've contaminated this water sample. We were analyzing the sample for microorganisms. It passed all the routine tests, and I just could not see how a water sample that smelled that bad could pass all the tests and get approved." Actually, there was a leak at this gas station and the leak contaminated the water supply: "That prompted my interest in microbiology and contamination problems." Joe went on to graduate school, studying under Dr. Hap Pritchard, who opened his eyes to possibilities in science. At that time, there were oil tankers running aground and it was the height of the environmental movement. All that came together in his mind with being in Hap Pritchard's lab where they were investigating the fate of oil that had spilled: "All of it centered on what role the microorganisms play in influencing the fate of materials that are released in the environment."

During his graduate work with Hap, Joe had other research-career-changing events:

Hap sent me to a meeting where I heard a talk by the great Marv Bryant of the University of Illinois and he talked about methanogens; that was the early days of methanogenesis. I remember him making a statement that "these organisms are as different from other bacteria as humans are from bacteria." That just blew my socks off at that point. It stimulated an interest in the anaerobic side of things. The other thing that absolutely stunned me was when I was working at Penn State with Jean-Marc Bollag, and I was looking at soil microbiology. I remember getting frustrated with my inability to go out to the field and make reproducible measurements. So, I took a meter square of soil and did the particular assay I was working with, and of course, microbial activities varied by orders of magnitude within one meter. This gave me a perspective of how a mm on the microbial scale is equivalent to kilometers on the human scale.

These varied events have shaped the research career of one of today's prominent microbial ecologists.

TABLE 12.5. Production of Biofuels by Microorganisms

Biofuel	Substrates	Principal Microorganism Involved
Ethanol	Corn (maize) or sugarcane Lignocellulose from hay, grass, and plant products Synthesis gas (CO + H <sub>2</sub> + CO <sub>2</sub> )	<i>Saccharomyces cerevisiae</i> <i>Saccharomyces cerevisiae</i> and <i>Pichia stipitis</i> <i>Clostridium ljungdahlin</i> , <i>C. carboxidivorans</i>
Butanol	Corn or Jerusalem artichoke	<i>Clostridium acetobutylicum</i>
Methanol	CO <sub>2</sub>	Methanogens
H <sub>2</sub>	Sunlight (photosynthesis) with reducing activity from photosystem I	<i>Chlamydomonas reinhardtii</i>
CH <sub>4</sub>	Organic acids and various organic compounds	Methanogens

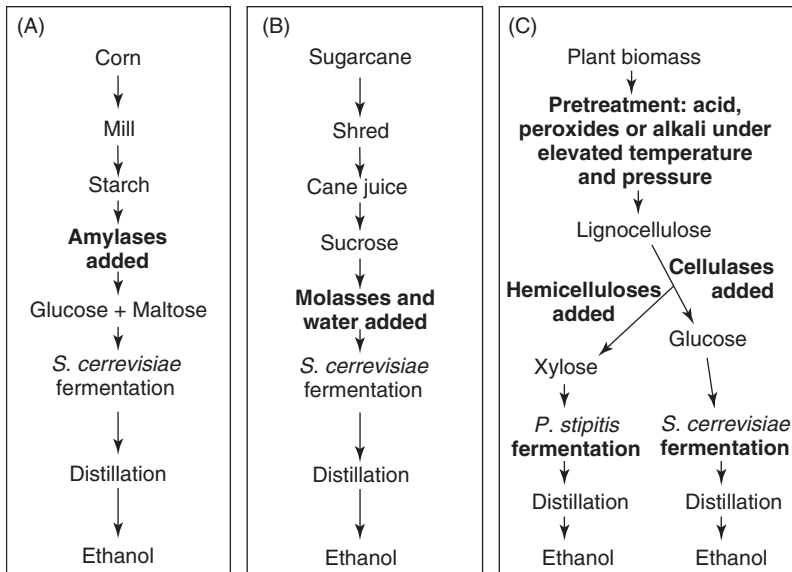
### 12.9.1 Alcohol Production

Corn is produced on many farms (see Figure 12.14) for internal-combustion engines, where ethanol is mixed with gasoline. Ethanol is produced by various microorganisms; yeast fermentation is the most common, and an outline of processes using three different fermentable substrates is given in Figure 12.15. Ethanol production from corn is a variation of yeast fermentation in the brewing process (Nichols et al. 2008). Starch granules released from corn kernels is solubilized in hot water, and  $\alpha$ -amylase is added to hydrolyze the linear bonds in starch to produce glucose, maltose, and limit dextrin. This liquification process is followed by saccharification, where sugars are released from starch. Important in the saccharification process is the addition of glucoamylase, which completes the conversion of limit dextrin to glucose. The industrial sources of  $\alpha$ -amylase and glucoamalyase are *Bacillus* sp. and *Aspergillus* sp., respectively. *Saccharomyces cerevisiae* ferments glucose to ethanol with distillation used to complete the process. Ethanol production from sugar cane relies on the fermentation of sucrose-rich cane juice by *S. cerevisiae*.



**Figure 12.14.** Cornfield on Herb Peterson farm, Raymond, Minnesota: (A) robust corn plants produce grain (B) with corn kernels; starch in corn kernels is the substrate for alcohol production by yeast (photographs by Larry Barton).





**Figure 12.15.** Different fermentation processes for the production of alcohol: (A) corn as the sugar source; (B) sugarcane as the sugar source; (C) cellulosic biomass as the sugar source.

More recently there has been interest in the conversion of lignocellulose in plant biomass to ethanol; however, this is a two-step process involving *S. cerevisiae* to ferment sugars released from plant cellulose by cellulosic enzymes and the use of *Pichia stipitis* to ferment xylose released from lignin by the addition of appropriate enzymes. Since *S. cerevisiae* is unable to ferment xylose, there is some interest in transferring appropriate genes from *P. stipitis* to *S. cerevisiae*. Xylose makes up about 15–25% of lignocellulosic biomass from straw, paper, cardboard, and assorted wood products. These biomasses contain 20–35% cellulose, 20–35% hemicellulose, and 10–25% lignin (Liu et al. 2008). Significant quantities of ethanol are produced by *P. stipitis* with 0.4 g/g ethanol from xylose or wheat straw. Potential sources of lignocellulosic biomass include switchgrass, Bermuda grass, *Miscanthus*, and other fast-growing grasses. Additionally, there is the potential to use the fibrous residue from sugarcane fermentation for lignocellulosic fermentation and to discontinue the practice of burning the cane fiber for steam production.

### 12.9.2 H<sub>2</sub> Production

As a result of anaerobic metabolism, many bacteria produce H<sub>2</sub>; however, in terms of economics, the most promising process for commercialization is the use of algae for photosynthetic production of H<sub>2</sub>. While production of O<sub>2</sub> is a product of algal photosynthesis in normal situations, H<sub>2</sub> can be produced by algae under specific environmental conditions (Seibert et al. 2008). In sulfur-limiting conditions, the internal O<sub>2</sub> movement is rechanneled with the result that the algal cell synthesizes hydrogenase and produces molecular hydrogen. In green algae and cyanobacteria, hydrogenase activity with H<sub>2</sub> production is coupled to reduced ferredoxin at the photosystem I site. The potential for light-driven H<sub>2</sub> production is great compared to other bioenergy considerations. If one would consider the area of land required for equivalent energy production, the area for

ethanol production from switchgrass is about 30 times greater than the area for equivalent energy production of H<sub>2</sub> by algae and about 200 times the area for equivalent ethanol production from corn.

### 12.9.3 Methane Production

Methane is commonly a product of anaerobic decomposition of organic matter. In lakes, methane collects in the mud and is released into the water column as bubbles. When organic matter is metabolized anaerobically, numerous physiological types of bacteria (guilds) participate in a cooperative manner to convert the organic polymers to the final end products. As depicted in Figure 12.16, the anaerobic consortium accomplishes the decomposition in a stepwise manner. This is in contrast to aerobic decomposition, where a single cell can convert the raw organic material completely to CO<sub>2</sub>. There are numerous species of methanogenic archaea, and the biochemical characteristics are highly specialized for production of methane (Ferry 1993). There is considerable potential for the use of wastes in production of biofuels such as methane, and the fermentable features of several wastes are presented in Table 12.6 (Angenent and Wrenn 2008). Wastes such as in slaughterhouse water, where the fat content is considerable, are not appropriate for fermentation leading to methane production because fats are not easily decomposed under anaerobic conditions.

As a natural process of microbial degradation of organic matter, bacteria produce numerous gases, and methane is the principal one formed. With the biological production in deep oceans and Arctic permafrost environments where the temperature is low and pressure may be considerable, methane will combine with water to produce clathrate hydrates, also referred to as *methane hydrates* (Parkes et al. 2000). Methane hydrates are an important reservoir of potential fuel and are estimated to represent about 5% of organic carbon on Earth.

Not all biomethane production is detrimental because cows and other cloven-hoofed animals rely on microbial decomposition of plant material. The cows shown in Figure 12.17 use bacteria and archaea to decompose cellulose to methane, and the cow

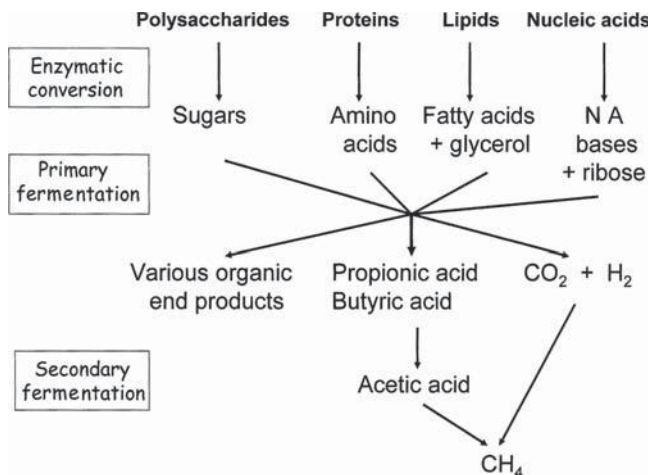


Figure 12.16. Process for decomposition of organic polymers to methane (NA = nucleic acids).

TABLE 12.6. Composition of Wastes with Potential for Biofuels

Source	Chemicals Present as a Percent			
	Carbohydrate	Protein	Fat	Lignin
Municipal wastewater	25–50	40–60	10	–
Whey	67	13	18	–
Apple pomace	50	27	2–10	–
Cattle manure	47	10	–	20
Swine manure	42	20	–	–
Slaughterhouse wastewater	—	30–65	45–75	–
Fruit canning	50–60	–	–	–
Potato waste	95	–	–	–
Brewery wastewater	–	12–19	–	–



**Figure 12.17.** Decomposition of plant materials by bacteria and archaea support the growth of cows on this farm in northern Germany; plastic covers ensilage (see arrow), which is another food for cows (photograph supplied by Larry Barton). See insert for color representation.

lives on the metabolic end products as well as from digestion of the microbial cells. Many plant materials may be used as cattle feed, and this could include green sorghum or green corn processed into ensilage. Natural bacteria on the corn or sorghum will grow on nutrients released from the chopped plants and produce lactic acid as an end product of fermentation. The increased acidity due to acid production acts as a preservative and inhibits further bacterial growth. As shown in Figure 12.17, this ensilage is stored as a long pile on the ground under a plastic cover to maintain anaerobic conditions.

#### 12.9.4 Biodiesel Production by Algae

Glycerol production by the marine alga, *Dunaliella* spp., has been known for several decades (Grizeau and Navarro 1986); however, it has never evolved into a

commercially profitable process. More recently there has been considerable excitement about oil production by various strains of algae and the potential for fermenting algae for the production of ethanol. The green alga *Botryococcus braunii* secretes a linear hydrocarbon that ranges from C<sub>30</sub> to C<sub>36</sub>, and this highly viscous oil makes up about one-third of the cell dry mass. Following extraction of oil from algae with a solvent, ethanol is added to produce a fuel called *biodiesel* (Chisti 2007). This has been proposed as a potentially profitable process, and several companies are actively pursuing its development. The amount of oil produced by algae per acre is 50–100 times greater than that produced by canola or soybeans. There is some speculation that hydrocarbon producing algae growing in lake beds in early geologic time could have produced oil found in certain types of shale.

## 12.10 WASTE TREATMENT SYSTEMS

One of the major challenges confronting people around the world is the management of waste treatment that is commonly associated with sewage treatment. As indicated in Table 12.6, there are industrial, agricultural, and food-processing wastes; however, this section focuses on municipal sewage wastewater systems carrying domestic sewage. Perhaps one of the greatest contributions of civil engineering has been the design of sewage treatment systems that are both healthful and environmentally supportive (Crites et al. 2006). Because of the dense urban settings, hundreds to thousands of tons of solids from domestic units enter the waste treatment system of a major city, and the objectives are as follows: (1) stimulate native bacteria to oxidize organic matter to produce CO<sub>2</sub> plus inorganic nitrogen and sulfur compounds, (2) collect and remove bacteria and other solids from the wastewater, and (3) inactivate or destroy disease-producing agents that would be in solids or liquids leaving the treatment facility. A sewage treatment system can be a multi-million-dollar operation that incorporates physical, biological, and chemical treatment processes.

A diagram indicating an appropriate system for processing domestic sewage in urban settings is given in Figure 12.18. As raw sewage enters the treatment facility, it is subject to a primary treatment that involves physical removal of insoluble debris that may be flushed down the drain. The following step is biological treatment, which may involve both aerobic and anaerobic microbial metabolism of chemicals dissolved in the water. Historically, trickling beds were used for aerobic treatment where water containing organic material was slowly sprayed on the surface of biofilms supported on a rock matrix. Aerobic oxidation encouraged bacteria in the biomat to grow and convert nutrients in the water to cell biomass. To increase the rate of aerobic biological treatment of wastewater, aeration tanks have supplemented or replaced trickling filter systems. Solids from the aerobic oxidation stage of treatment are collected and placed in large tanks for anaerobic biological treatment, where digestion follows the metabolism outlined in Figure 12.16.

A product of mixed fermentation in the anaerobic tanks is methane. Methane may be burned in engines to produce energy and, thereby, reduce the cost of the treatment facility. The sludge or solids from the fermentation tanks is removed and may be either buried or used as fertilizer following treatment to inactivate bacteria and viruses. Wastewater from the sewage treatment facility is subjected to a chlorine treatment process to destroy pathogenic bacteria and viruses. In some municipal systems high-intensity ultraviolet light is being used to substitute for chlorine treatments. Effluent from the wastewater

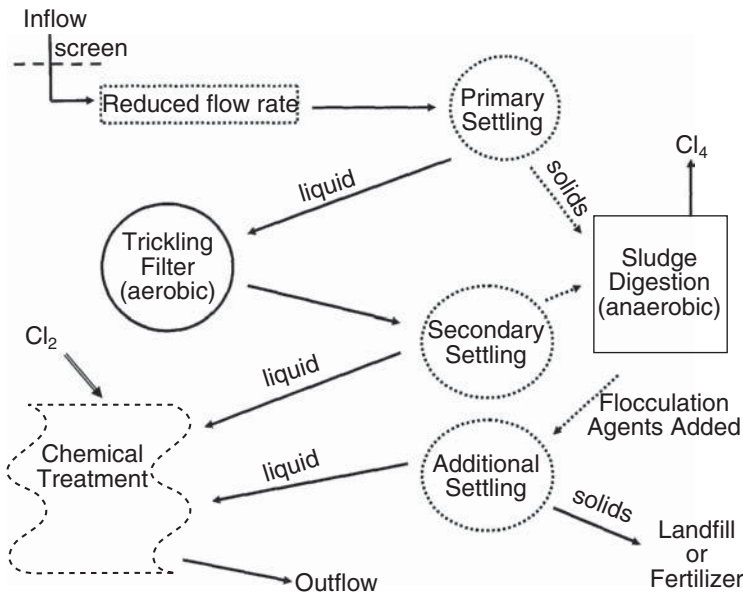


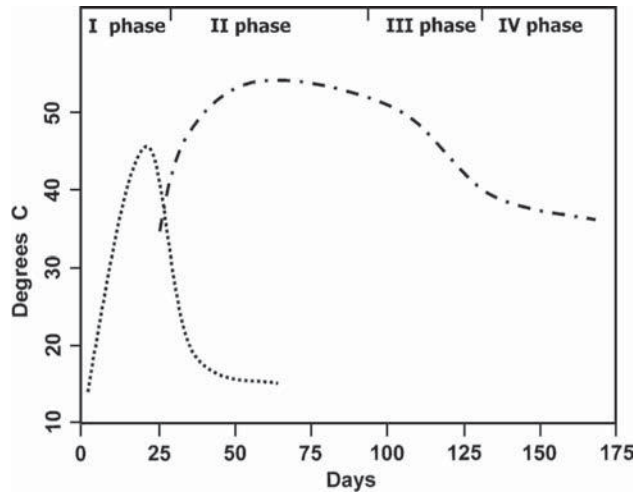
Figure 12.18. General scheme for urban treatment of domestic sewage.

facility is examined to ensure that nitrate or other chemicals are not at toxic levels. To predict the holding time for biological treatment of wastewater, biological oxygen demand (BOD) measurements are conducted to calculate the amount of oxygen required for aerobic metabolism of organic material in the wastewater.

## 12.11 COMPOSTING OF PLANT ORGANIC MATTER

Composting is the decomposition of organic matter by natural biological processes and is distinguished from mineralization of dead plant material in that composting involves microbial heating of the organic matter; the final product is highly stable and safe to apply to the soil. Programs involving composting usually include processing of green plant materials and in some cases apply to segments of municipal solid wastes in landfills (Fogarty and Tuovinen 1991). The size of the composting may range from backyard piles of grass to open fields. Four phases are generally defined by the temperatures of the composting process; these stages are illustrated in Figure 12.19.

The initial phase is the growth of mesophilic bacteria and fungi already present on the grass. These organisms grow on sugars, proteins, starches, and fats released from the plant cells. Many different species of bacteria are present; the most prevalent are ubiquinone containing Proteobacteria in the early portion of the initial phase, and toward the latter portion of this phase Actinobacteria become dominant. Over 140 different bacterial species were identified in a composting process treating household biowastes, with most of the isolate belonging to the phyla of Actinobacteria, Bacteroidetes, and Firmicutes, with numerous species of *Bacillus*, *Cellulosomicrobium*, and *Ornithinococcus* (Narihiro and Hiraishi 2005). Soil fungi present on the grass will also grow on the soluble nutrients; however, their growth is not as fast as that of bacteria. As aerobic metabolism



**Figure 12.19.** Phases of composting plant material: (I) initial or mesophilic phase; (II) active or thermophilic phase; (III) initial curing or cooling phase; (IV) final curing or maturation phase. Temperatures attributed to mesophilic microorganisms (dotted line) and to thermophilic microorganisms (dashed line)

proceeds, about 40% of energy from microbial metabolism is lost as heat and results in heating the pile to about 40–45°C. At this temperature, the mesophilic organisms are inactivated but spores from the mesophilic spore producers remain viable.

The second phase, also called *thermophilic* or *active phase*, is longer than the initial phase and is the time when thermophilic fungi and bacteria grow. It is in this phase that organic matter is decomposed to carbon dioxide and humus. These organisms release heat as they are growing aerobically, and the elevated temperatures promotes enzymatic hydrolysis of plant macromolecules. As the temperature of the composting increases to about 60°C, the temperature destroys viruses, human pathogens, and weed seeds.

In a properly maintained compost pile, the temperature of composting decreases because the soluble nutrients are being depleted. As the temperature decreases, cellulose, lignin, and pectin are decomposed by mesophilic bacteria, especially actinomycetes. This third stage of composting includes the production of humic substances by actinomycetes that initiates the curing process. The fourth phase in composting is the final curing or maturation process where mesophiles complete the formation of humus. As an additive to the soil, humus is highly desirable because it resists decomposition by soil microorganisms and contributes to the retention of nutrients, trace metals, and water. Humus is highly desirable in that it promotes root growth and microbial activities in the soil.

Management of composting is important for optimal conversion of biomaterial to humus. The plant material should be kept moist, and the type of mesophilic bacteria dominant in the process is influenced by the moisture content. Saturation of the compost with water is to be avoided to prevent anaerobic conditions. Under the anaerobic state, decomposition of organic matter to carbon dioxide is greatly reduced and the temperature quickly rises to 170°F, with the destruction of thermophilic bacteria and fungi. To restart the composting, it is necessary to add fresh compost material (a source of nutrients) and introduce mesophilic organisms into the compost. Bacteria on the surface of the compost pile are seldom subjected to the high temperatures, and mixing the compost pile will



serve to redistribute the bacteria and fungi. It is a special challenge to compost plant material containing pesticides and insecticides (Fogarty and Tuovinen 1991) because these compounds may not be destroyed in the composting process.

Additional management practices in composting include the evaluation of carbon, nitrogen, and sulfur compounds in the plant material used for composting. There is an optimal elemental C/N ratio for microbial composting. At the start of the composting process, the C/N ratio should be approximately 30 and as microbial decomposition of plant material proceeds, the C/N ratio will diminish to about 10. With dry leaves or sawdust, the C/N ratio is 50–80, and nitrogen must be added to initiate the composting process. On the other hand, if grass clippings are to be composted, the C/N ratio of these clippings may be about 20, and if composting is initiated, there will be microbial release of ammonia with an increase in alkalinity. Undesirable odors come from composting processes are attributed to thiols, ammonia, amines, and organic acids. To reduce odors from composting, it is desirable to reduce the levels of sulfur and nitrogen compounds in the starting material.

Natural composting occurs in woodlands as tree leaves and dead plants collect on the ground. In some cases, there can be several inches of plant debris on the forest floor. In wetland areas (see Figure 12.20), the decomposition of plant material is more often anaerobic than aerobic. As dead plant material collects in the water, aerobic processes occur initially, but anaerobic activities predominate in the mud region.

## 12.12 IMPACT OF MICROBIAL DEGRADATION ON HUMANS

After many centuries of microbial growth, the deterioration of cultural art objects or stone structures may become apparent. These microorganisms may be ectolithotrophic, growing on the surface of the object, and as the cells penetrate the material, the growth becomes endolithotrophic. Green-black pigmentation on stone surfaces (see Figure 12.21) exposed



**Figure 12.20.** Wetland region along Rio Grande River in New Mexico; plant material falling into the marsh is subjected to natural composting (photograph supplied by Larry Barton).



**Figure 12.21.** Microorganisms growing on stone; lichens and cyanobacteria growing on walls of a building in northwestern Spain (photograph by Larry Barton). See insert for color representation.

to light is generally attributed to lichen, cyanobacteria, or algal biofilm development. Fungi and bacteria will grow in the biofilm using nutrients supplied by cyanobacteria that convert  $N_2$  and  $CO_2$  to organic compounds. The organic acid products of fungal and bacterial metabolism remove  $Ca^{2+}$  from limestone or stone material. Many of the materials used for easel paintings or mural paintings contain nutrients metabolized by bacteria and fungi (Ciferri 1999). Paints often contain mixtures of animal proteins or fats with colored minerals, and plant or animal materials were generally used to prepare the surface for painting. If the environment could be kept dry, fungal or bacterial growth was less of a problem than when the area was humid. As can be seen in Table 12.7, deterioration of historic monuments can be severe. Since the use of chemical or physical methods to restore cultural art objects may be detrimental, scientists are exploring the possibilities of using microorganisms (Konkol et al. 2008). There is the possibility that bacteria may be used to remove sulfate crusts from surfaces of stone monuments without damaging the surface. Another possibility is that bacteria could produce calcium carbonate that would consolidate mineral surfaces in damaged stone.

Microbial deterioration of paint, concrete, and construction materials can be observed over a relatively short time. Fungi will grow on painted surfaces if the area is humid, and this discolored appearance is often called mildew. To control the problem of *Pullularia*, *Cladosporium*, *Aspergillus*, and *Penicillium* growing on painted surfaces, antifungal compounds are incorporated into the paint. The walls of concrete pipes can be weakened by thiobacilli converting volatile hydrogen sulfide to sulfuric acid, with the acid dissolving the concrete structure (Bock and Sand 1993). In most instances, the sulfate-reducing bacteria in the sediment of the pipe are the source of the hydrogen sulfide.

Fungal growth on wood, dryboard, and other construction material have been associated with the “sick building” syndrome. The causative agent is *Stachybotrys*, a soil fungus, and buildings that are infected with *Stachybotrys* are frequently vacated until the fungi have been removed. Individuals working in buildings where the fungus is growing often display a variety of respiratory symptoms and allergic reactions. Exposure to

TABLE 12.7. Examples of Microbial Deterioration of Important Cultural Items

Historic Site	Characteristics	Reference
Lascaux Cave, Dordogne region, France	Prehistoric paintings of animals were covered with algae, cyanobacteria, bacteria, and fungi following opening to the general public	Ciferri (1999)
Crypt of Original Sin, Matera, Italy	Rosy discoloration of medieval frescoes was attributed to pigment produced by <i>Rubrobacter radiotolerand</i> -related bacteria	Imperi et al. (2007)
500-year-old Mosques Erzurum, Turkey	Deterioration of stone monuments due to chemolithotrophic bacteria solubilizing the stone	Nuhoglu et al. (2005)
Wooden huts, Ross Island, Antarctica	Wooden huts of 1901 expedition by Scott and Shackleton are being degraded by soft rot fungi, including <i>Cadophora</i>	Konkol et al. (2008)
Mayan stoneworks at Ék' Balam, Yucatan, Mexico	Algae and cyanobacteria stain the stone surfaces green to black, and fungi plus heterotrophic bacteria collect on algal biofilm to promote further deterioration	Konkol et al. (2008)

*Stachybotrys* is to be avoided because the fungus produces trichothecene mycotoxins that are inhibitors of protein synthesis (Page and Trout 2001). Removal of wallboard and other materials containing *Stachybotrys* is required to make the building livable. Buildings that have been flooded or exposed to high humidity are likely candidates of sick building syndrome.

### 12.13 SUMMARY

In any microbial community, certain organisms are able to hydrolyze macromolecules of plant or animal origin and use the products of this hydrolysis to support their growth. Many different heterotrophic bacteria rapidly consume soluble nutrients entering the soil or aquatic environment from plants and animals; however, metabolic specialists are required to degrade structural materials of plants (e.g., cellulose, hemicellulose, lignin) and animals (e.g., collagen, keratin, chitin, fibroin). The unique biomaterial serves to select for growth of specific microorganisms, but the responding microorganism may support many other microorganisms. In the case of starch added to the environment, bacteria and fungi with amylase are selected. If the degradation of starch is by enzymes released from the cells, any microorganism in the environment may use the sugars released from starch hydrolysis. However, bacteria that produce cellulosomes are the only microorganisms that benefit from sugars released from cellulose hydrolysis. Following any rapid growth of microorganism, there is a death phase, and nutrients released from dead microorganisms are used to support microorganisms in the environment. Thus, microorganisms will continue to grow as long as there is a substrate in the environment that can be used for energy and the physical environment supports growth. Some decomposition activities are initiated by an abundance of readily utilized compounds, and

consortia of microorganisms become established to utilize these nutrients. In the case of fermentation of wastewater solids, there is a succession of consortia culminating in the production of methane.

Over the years, several microbial processes have been used to benefit society. Fermented foods were an important contribution to human health, and although there is a chemical preservation process applied using acetic and lactic acids, this is a modification of the natural microbial process. Currently, there is an industry evolving that is examining microbial processes for biofuel production. Solid-waste accumulation is an important byproduct of modern society, and application of microbial processes to this problem will be important. As natural decomposition by microorganisms is studied in greater detail, there are sure to be new applications in which microorganisms are important.

### 12.14 DELVING DEEPER: CRITICAL THINKING QUESTIONS

1. Are plant structural molecules more difficult for microorganisms to degrade than macromolecules produced by animals? If so, suggest a reason why.
2. What is the advantage for bacteria to have cellulosomes for degradation of cellulose?
3. What would have been the evolutionary pressure that would account for animals not producing enzymes for hydrolysis of cellulose microfibrils?
4. Make comparisons between composting and domestic wastewater treatment. How would these two processes differ?
5. What contributions could genetic engineering make to bioenergy production?
6. What are some of the major problems in using switchgrass or other agricultural grasses for ethanol production?
7. What would be the major considerations in using poultry feathers for the production of ethanol or methane?
8. Some researchers have claimed that production of fermented foods or beverages is a stalled decomposition process. Defend or refute this statement.
9. What is the best approach to stop microbial deterioration of frescoes or cultural murals?
10. Have the cultural artifacts in the burial crypts been subjected to microbial deterioration? Defend your answer.
11. What may have accounted for the discovery hundreds of years ago that rennin from the stomach lining of calves would contribute to curdling of milk?
12. Since hemicellulose is difficult for microorganisms to hydrolyze, is it possible to use molecular biology to produce plants low in hemicellulose for bioenergy production?

### BIBLIOGRAPHIC MATERIAL

#### Further Reading

Adl SA (2003), *The Ecology of Soil Decomposition*, Cambridge, MA: CABI Publishing.

- Alexander M (1994), *Biodegradation and Bioremediation*, New York: Academic Press.
- Arora DK, Ajello L, Mukerji KG (1991), *Handbook of Applied Mycology*, Vol. 3: *Foods and Feeds*, Boca Raton, FL: CRC Press.
- Bayer EA, Belaich JP, Shoham Y, Lamed R (2004), The cellulosomes: multienzyme machines for degradation of plant cell wall, *Annu. Rev. Microbiol.* **58**:521–554.
- Davet P (2004), *Microbial Ecology of the Soil and Plant Growth*, Enfield, NH: Science Publishers.
- Deacon J (2006), *Fungal Biology*, 4th ed., Oxford, UK: Blackwell Publishing.
- Hofrichter M (2002), Review: Lignin conversion by manganese peroxidase (MnP), *Enzyme Microbial Technol.* **30**:454–466.
- Kutzner HJ (2000), Microbiology of composting, in Klein J, Winter J, eds., *Biotechnology, A Multi-Volume Comprehensive Treatise*, Vol. 11c: *Environmental Processes III*, 2nd ed., New York: Wiley-Interscience, pp. 36–99.
- Mitchell R, McNamara CJ (2010), *Cultural Heritage Microbiology: Fundamental Studies in Conservation Science*, Washington, DC: ASM Press.
- Sabour PM, Griffiths MW (2010), *Bacteriophages in the Control of Food and Waterborne Pathogens*, Washington, DC: ASM Press.
- Scheerer S, Ortega-Morales O, Gaylarde C (2009), Microbial deterioration of stone monuments—an updated overview, *Adv. Appl. Microbiol.* **66**:97–140.
- Schwan RF, Wheels AE (2004), The microbiology of cocoa fermentation and its role in chocolate quality, *Crit. Rev. Food Sci. Nutr.* **44**:205–221.

### Cited References

- Angenent LT, Wrenn BA (2008), Optimizing mixed-culture bioprocessing to convert wastes into bioenergy, in Wall JD, Harwood CS, Demain A, eds., *Bioenergy*, Washington, DC: ASM Press, pp. 179–194.
- Bock E, Sand W (1993), The microbiology of masonry deterioration, *J. Appl. Bacteriol.* **74**:503–514.
- Chisti Y (2007), Biodiesel from microalgae, *Biotechnol. Adv.* **25**:294–306.
- Ciferri O (1999), Microbial degradation of paintings, *Appl. Environ. Microbiol.* **65**:879–885.
- Crites RW, Middlebrooks EJ, Reed SC (2006), *Natural Wastewater Treatment Systems*, Boca Raton, FL: CRC Taylor & Francis.
- Demain AL, Newcomb M, Wu JHD (2005), Cellulase, clostridia, and ethanol, *Microbiol. Molec. Biol. Rev.* **69**:124–154.
- Doi RH (2008), Cellulosomes from mesophilic bacteria, in Wall JD, Harwood CS, Demain A, eds., *Bioenergy*, Washington, DC: ASM Press, pp. 97–107.
- Ezeji TV, Blaschek HP (2008), Practical aspects of butanol production, in Wall JD, Harwood CS, Demain A, eds., *Bioenergy*. Washington, DC: ASM Press, pp. 335–346.
- Ferry JG, ed. (1993), *Methanogenesis*, New York: Chapman & Hall.
- Fogarty AM, Tuovinen OH (1991), Microbiological degradation of pesticides in yard waste composting, *Microbiol. Rev.* **55**:225–233.
- Ghosh P, Singh A (1993), Physicochemical and biological treatments for enzymatic/microbial conversion of lignocellulosic biomass, *Adv. Appl. Microbiol.* **39**:295–333.
- Gooday GW (1990), The ecology of chitin degradation, *Adv. Microbial Ecol.* **11**:387–431.
- Grande JM, Negro JJ, Torres MJ (2004), The evolution of bird plumage coloration: A role for feather-degrading bacteria? *Ardeola* **51**:375–383.

- Grizeau D, Navarro JM (1986), Glycerol production by *Dunaliella tertiolecyca* immobilized within Ca-alginate beads, *Biotechnol. Lett.* **8**:261–264.
- Imperi F, Caneva G, Cancellien L, Ricci MA, Sodo A, Visca P (2007), The bacterial aetiology of rosy discoloration of ancient wall paintings, *Environ. Microbiol.* **9**:2894–2902.
- Konkol NR, McNamara CJ, Blanchette RA, May E, Mitchell R (2008), Microbes can damage but also help restore artifacts, *Microbe* **3**:563–567.
- Law BA, ed. (1999), *Technology of Cheese Making*, Sheffield, UK: Sheffield Academic Press.
- Liu ZL, Saha BC, Slininger PJ (2008), Lignocellulosic biomass conversion to ethanol by *Saccharomyces*, in Wall JD, Harwood CS, Demain A, eds., *Bioenergy*, Washington DC: ASM Press, pp. 17–47.
- Lynd LR, Weimer PJ, van Zyl WH, Pretorius IS (2002), Microbial cellulose utilization: Fundamentals and biotechnology, *Microbiol. Molec. Biol. Rev.* **66**:506–577.
- Mishra P, Singh A (1993), Microbial pentose utilization, *Adv. Appl. Microbiol.* **39**:91–153.
- Narihiro T, Hiraishi A (2005), Microbiology of fed-batch composting, *Microbes Environ.* **20**:1–13.
- Nichols NN, Monceaux DA, Dien BS, Bothast RJ (2008), Production of ethanol from corn and sugarcane, in Wall JD, Harwood CS, Demain A, eds., *Bioenergy*, Washington DC: ASM Press, pp. 3–15.
- Nuhoglu Y, Oguz E, Uslu H, Ozbek A, Ipekoglu B, Ocak I, Hasenekoglu I (2005), The accelerating effects of the microorganisms on biodeterioration of stone monuments under air pollution and continental-cold climate conditions in Erzurum, Turkey, *Sci. Total Environ.* **364**:272–283.
- Page EH, Trout DB (2001), The role of *Stachybotrys* mycotoxins in building-related illness, *Am. Industr. Hygiene Assoc. J.* **62**:644–648.
- Parkes RJ, Cragg BA, Wellsbury P (2000), Recent studies on bacterial populations and processes in marine sediments: A review, *Hydrogeol. J.* **8**:11–28.
- Riffel A, Brandelli A (2006), Keratinolytic bacteria isolated from feather waste, *Brazil. J. Microbiol.* **37**:395–399.
- Rising A, Nimmervoll H, Grip S, Fernandez-Arias A, Storckenfeldt E, P. Knight DP, Vollrath F, Engström W (2005), Spider silk proteins—mechanical property and gene sequence, *Zool. Sci.* **22**:273–281.
- Sakai T, Sakamoto T, Hallaert J, Vandamme EJ (1993), Pectin, pectinase and protopectinase: Production, properties, and applications, *Adv. Appl. Microbiol.* **39**:213–295.
- Sasikala CH (1996), Biodegradable polyesters, *Adv. Appl. Microbiol.* **42**:97–219.
- Seibert M, King PW, Postewitz MC, Melis A, Ghirardi ML (2008), Photosynthetic water-splitting for hydrogen production, in Wall JD, Harwood CS, Demain A, eds., *Bioenergy*. Washington DC: ASM Press, pp. 3–15.
- Shetty K, Paliyath G, Pometto A, Levin RE (2006), *Food Technology*, 2nd ed., Boca Raton, FL: CRC Press.
- Singh A, Hayashi K (1995), Microbial cellulases: Proteins architecture, molecular properties and biosynthesis, *Adv. Appl. Microbiol.* **40**:1–44.
- Suzuki Y, Tsujimoto Y, Matsui H, Watanabe K (2006), Decomposition of extremely hard-to-degrade animal proteins by thermophilic bacteria, *J. Biosci. Bioeng.* **192**:73–81.
- Tanner RS (2008), Production of ethanol from synthesis gas, in Wall JD, Harwood CS, Demain A, eds., *Bioenergy*, Washington, DC: ASM Press, pp. 147–151.
- Vandamme EJ, Derycke DG (1983), Microbial inulinases: Fermentation processes, properties and applications, *Adv. Appl. Microbiol.* **29**:139–176.
- Watanabe K (2004), Collagenolytic proteases from bacteria, *Appl. Microbiol. Biotechnol.* **63**:520–526.
- Xin YY, Cui JR, Niu JZ, Hua, SF, Xia CG, Li SB, Zhu LM (2004), Biosynthesis of methanol from CO<sub>2</sub> and CH<sub>4</sub> by methanotrophic bacteria, *Biotechnology* **3**:67–71.



Yang S-J, Kataeva I, Hamilton-Brehm SD, Engle NL, Tschaplinski TJ, Doepke C, Davis M, Westpheling J, Adams MWW (2009), Efficient degradation of lignocellulosic plant biomass, without pretreatment, by the thermophilic anaerobe "*Anaerocellum thermophilum*" DSM 6725, *Appl. Environ. Microbiol.* **75**:4762–4769.

## MICROBES AT WORK: BIOREMEDIATION

---

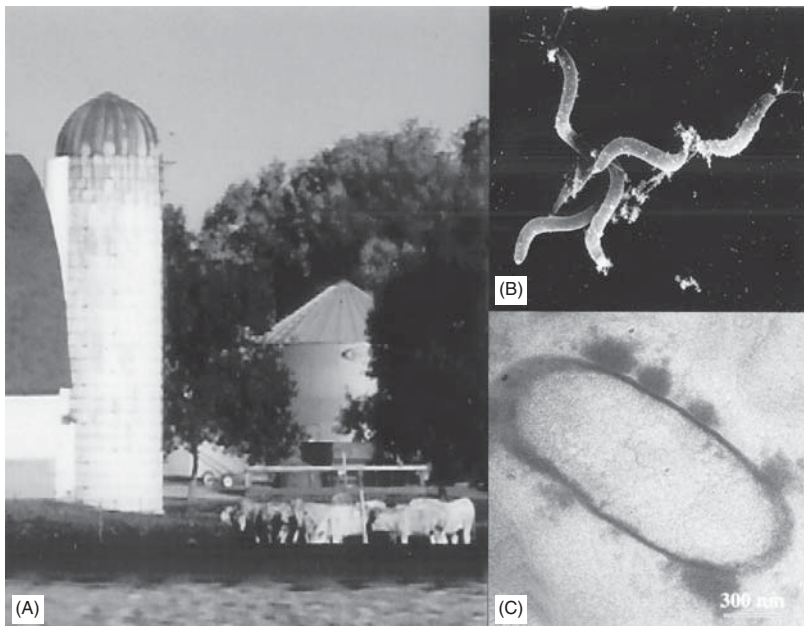
### 13.1 CENTRAL THEMES

- Various physiological types of microorganisms are present in the environment and are capable of degrading petroleum products that are environmental pollutants.
- Appropriate nutrient addition to natural environments selects for bacterial metabolism of organic and metal pollutants.
- The goal of microbial treatment of organic matter as pollutants is complete mineralization to carbon dioxide.
- Microbial treatment of toxic metals as pollutants is to remove the metals from the environment through immobilization.
- Anthropogenic chemicals that are degraded slowly by microorganisms are a challenge for environmentalists.
- Using microorganisms to remediate toxic metals in the environment is a challenge because metals may be immobilized but remain in the environment.

## 13.2 INTRODUCTION

Microorganisms interact with everything in the environment, including anthropogenic chemicals that may be toxic to higher life forms. Examples of microorganisms in bioremediation are given in Figure 13.1. With the exception of a few synthetic organic-based polymers, indigenous microorganisms will mineralize anthropogenic organic compounds or natural hydrocarbons to carbon dioxide plus inorganic salts. Microorganisms became important for removal of organic pollutants because bioremediation was less expensive than chemical treatment and bioremediation was not destructive to the environment. In most cases, *in situ* bioremediation of organic pollutants is accomplished by adjusting environmental conditions to those established under defined conditions with pure cultures. The rate for microbial decomposition of organic compounds is optimal under syntrophic conditions and cometabolism. However, some contaminants persist because they are not soluble in water or bind to clay in the environment.

Another bioremediation effort used to detoxify the environment is the activity of microorganisms in the conversion of toxic soluble inorganic chemicals to insoluble forms that have markedly reduced toxicity. When toxic metals are dumped into the environment, there is a selection for bacteria that are resistant to metal cations or anions. This growth of bacteria in the presence of an inorganic chemical is an example of metal stress response.



**Figure 13.1.** Microorganisms working in bioremediation: (A) renewable resources in an agricultural setting. The cattle are fed ensilage and grain produced on the farm. Indigenous microorganisms in the soil metabolize plant and animal products for continued crop production. (B) Anaerobic bacteria such as *Desulfovibrio* detoxify chemical pollutants in the environment. (C) *Desulfovibrio desulfuricans* detoxifies the environment of molybdate by production of molybdenum sulfide that is immobilized outside the bacterial cell. (Photographs provided by Larry Barton.).

In some environments, the bioremediation of inorganic anions (e.g., selenate, arsenate, nitrate, or chlorate) has an environmental advantage over treatments that use chemicals for extracting or reacting with the toxic compound. This chapter provides insight into the role of microbial ecology in chemical detoxification using bioremediation.

**13.3 BIOREMEDIATION AS A TECHNOLOGY**

From a variety of activities, organic materials have polluted the environment, and society has expressed considerable interest in removing the polluted material. Often bioremediation is considered to be a relatively new process for treatment of contaminants, but in 1891 the first biological sewage treatment plant was opened in Sussex, UK. Thus bioremediation has been used for over 100 years, and currently the use of microorganisms to remediate environments polluted with various hazardous materials is considered. Examples of environmental pollutants are listed in Table 13.1 (Swoboda-Colberg 1995).

Contaminated soil or groundwater may be treated on site which may be desirable because toxic material is not transported to another area. Depending on the situation and site characteristics, organic materials or inorganic metals may be removed from the contaminated environment by either chemical treatment or microbial processes. In general, chemical treatments give immediate results but are expensive, while bioremediation is relatively inexpensive but proceeds slowly. In a few cases microbial remediation has been conducted on contaminated material that has been removed from the site and deposited in large reservoirs or piles. Microorganisms suitable for the remediation are generally present in groundwater or soil, and when nutrients are added to the environment, many physiological types of microbes in the soil will grow, including those that are appropriate for bioremediation. Alternately, microbial augmentation can be used, which is the addition of microbial inocula containing indigenous environmental bacteria that may be selectively grown in the laboratory. Under appropriate conditions, natural attenuation of polluted environments occurs as resident microorganisms conduct bioremediation over a period of time. As in the case of all environmental issues, risk assessments must be conducted to ensure that microbial treatment of organic pollution does not produce harmful effects.

The potential for use of microorganisms to remediate an environment contaminated with organic chemicals is great, and several approaches have been summarized in

**TABLE 13.1. Examples of Industries that Produce Toxic Organic Compounds and Pesticides of Environmental Concern**

Industry (Organic Compounds Produced)	Pesticides (Organic Compounds Produced)
Petroleum (chlorinated dioxine)	Fungicides (anthraquinones)
Plastic (methylmerthacrylate)	Herbicides (diuron, 2,4-D; 2,4,5-T)
Paint (methylisobutylketone)	Rodenticides (dicoumarol, warfarin)
Electronics (methylene chloride)	Insecticides (lindane, DDT)
Textile (dyes, alkylcarbamates)	Molluscicides (Trifenmorph)
Cosmetics (hydroxyquinolines)	Algicides (isocyanuric acid)
Metals (trichloroethane)	Nematicide (propargyl bromide)
Wood preservation (pentachlorophenol, cresols)	Acricide (azobenzene, Ovex)
Explosives (TNT, RDX)	

published reports (Wise and Trantolo 1994). Bioremediation is highly site-specific in that the chemical and physical characteristics of an environment influence the rate of microbial metabolism. Although generalizations can be made about the environment, each polluted site will have one or more parameters that limit microbial growth. In the case of organic pollutants, aerobic microbial metabolism is desired because this would completely oxidize an organic pollutant to carbon dioxide. If anaerobic microbial growth occurs, oxidation of organic pollutants would be incomplete and produce alcohols, acids, or other end products that may even be toxic. In cometabolism, a halogen-carbon bond is degraded by one bacterium without that organism receiving any benefit, and the organic compound released is used by a second bacterial strain. This detoxification of a pollutant by gratuitous metabolism occurs while the organism is growing on another carbon source and may be attributed to enzymes with low substrate specificity. Another gratuitous activity resulting in detoxification of organic molecules is *coculture*, where two unrelated bacterial strains modify a molecule but pure cultures are unable to metabolize this substrate.

### 13.4 GENETIC ENGINEERING

The presence of plasmids in bacteria often confers special catabolic processes, including the capability for hydrocarbon metabolism. With respect to hydrocarbon metabolism, distinct plasmids are known to carry out the degradation of xylene, toluene, *n*-octane, or naphthalene in Gram-negative bacteria (Chakrabarty 1976). For degradation of hydrocarbon, several species of bacteria are needed, but these species are not compatible when they are all introduced into an oil spill. In a remarkable demonstration of genetic engineering, Ananda Chakrabarty introduced four different plasmids associated with hydrocarbon metabolism into a single bacterial species and stabilized the plasmids so that the recipient bacterium, now classified as *Burkholderia* sp., could mineralize crude oil. By considering the genetically engineered bacterium as a “manufactured” item, Chakrabarty obtained the first patent awarded for work on living organisms and this led the way for patents on other genetically modified organisms. Other plasmids have been identified for degradation of various organic pollutants, including 2,4-D, chlorobenzoates, chlorophenols, chloroanilines, and chlorobiphenyls (Alexander 1994; Paul and Clark 1996). While there is concern about using genetic engineered microorganisms for environmental bioremediation, useful information about kinetics of decomposition and parameters for catabolism can be obtained with genetically modified bacteria growing in laboratory bioreactors.

### 13.5 DESIGN AND IMPLEMENTATION OF BIOREMEDIATION

#### 13.5.1 Bioreactors

Slurry-phase bioreactors of about 500 m<sup>3</sup> have been employed to treat contaminated soil. About 30% of the slurry is soil sieved to less than 200 mesh with soluble nitrogen and phosphorus added to stimulate microbial growth. After a couple of weeks of aeration, about 80% of the slurry is replaced with more contaminated soil. The residual soil contains microorganisms appropriate for the next treatment as the bioremediation proceeds. This process may be relatively expensive, but it has been used to remediate over 10,000 tons of creosote-contaminated soil (Woodhull and Jerger 1994).

### 13.5.2 Biofarming

Soil contaminated with organic compounds may be spread on agricultural or forest land in an effort to promote bioremediation. In several instances, soil from leaking oil storage tanks has been spread on fertile agricultural soil. An application rate commonly used is one cubic foot of contaminated soil applied to one square foot of land and there can be several applications each year. With millions of microorganisms per gram of soil, microbial degradation of hydrocarbons will proceed with plants providing nutrients for the microorganisms. The land is tilled frequently to promote aeration, and soil is fertilized with irrigation to promote plant growth. Obviously, the land used for bioremediation is not used for agriculture until the hydrocarbons are depleted. Since soil containing hydrocarbons or other organic pollutants may also have elevated levels of toxic metals, additions to farmland must be done with care. Soil low in organic content or arid soils should not be used for biofarming because appropriate organisms may be few, the metabolic activity of the microorganisms will not be a high, and the organic contaminants will remain in the soil for very long periods.

Land farming has been conducted with soil containing tar and creosote from wood treatment plants. Biofarming with tar and creosote is difficult because the pollutants are insoluble and application to the land is not uniform. White rot fungi are some of the few microorganisms that will degrade many of the molecules making up tar. In a bioremediation effort, contaminated soil from wood treatment plants has been applied to forested land where white rot fungi are abundant. Even when appropriate management practices of aeration and fertilization are used, it takes over a decade for bioremediation of tar-containing soil to be effective.

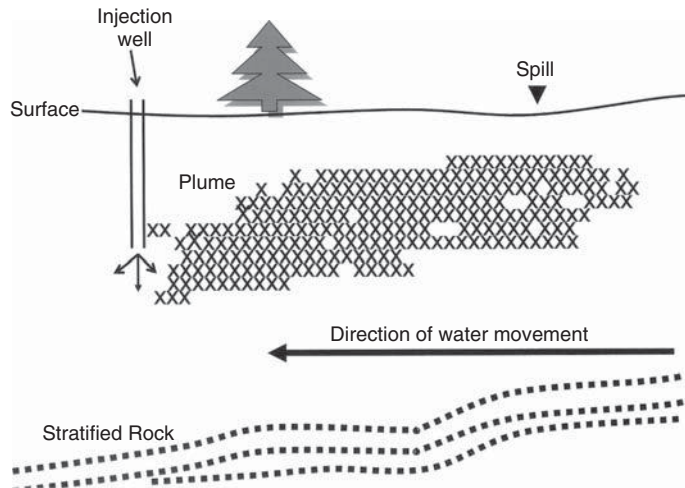
### 13.5.3 Permeable Reactive Barriers

When a large quantity of organic or inorganic material contaminates soil, the contaminant moves downward in the soil and is carried laterally in the soil by surface moisture. A model indicating this migration of contaminants and the development of a plume is given in Figure 13.2. If the plume is close to the surface and is moving slowly, a permeable reactive barrier may be used in bioremediation (Scherer et al. 2000; Davis and Patterson 2003). To construct a permeable reactive barrier, a trench is dug downgradient of the plume and filled with wood chips, hay, barnyard waste, and animal manure. The animal manure provides a broad mixture of bacteria and nutrients, while the inexpensive fibrous carbon material provides a carbon source that will be slowly degraded. As the plume of contamination moves through the barrier and is exposed to bacterial metabolism, the organic pollutant is oxidized and toxic metals are immobilized. Periodically, the matrix of the permeable reactive barrier can be removed, processed, and reconstructed.

### 13.5.4 Optimizing Bioremediation

**Nutrients.** To optimize bioremediation, the physicochemical environment is studied. Monitoring of groundwater at bioremediation sites requires scientists to collect water under anaerobic conditions (Figure 13.3). At some sites containing organic pollutants, the amount of available nitrogen, phosphorus, or carbon in the immediate environment is insufficient to support bacterial growth, and the general rule is to have an environment





**Figure 13.2.** Model of contaminant migration in porous soil. The contaminant is carried downgradient in the soil by the subsurface water. To enhance bioremediation, nutrients for indigenous bacteria are added through injection wells.



**Figure 13.3.** Portable hoods are used to collect groundwater for evaluation of bacteria and water quality; Keka C. Biswas is placing groundwater collected under anaerobic conditions in anaerobic bottles (photograph provided by Larry Barton).

with a C–N–P ratio of 100 : 10 : 1. For treatment of contaminated groundwater, nutrients are added by injection wells placed adjacent to the plume; however, additions must be done systematically to prevent plugging of the injection system with bacterial biomass.

Molasses is often used as a carbon supplement because it is inexpensive and contains numerous nutrients for bacteria. Various inorganic nitrogen compounds may be added to stimulate bioremediation, but additions of nitrate into an environment are generally

regulated. Selection of an added phosphate involves bioavailability of phosphate in the environment as influenced by adsorption to soil and precipitation. The optimal pH for *in situ* bioremediation is 6.5–8.0, and to achieve this desired pH, liming by the addition of calcium or magnesium carbonate is used to neutralize acidic soils, while additions of ammonium sulfate or ammonium nitrate are added to neutralize alkaline soils. Bioremediation may not be appropriate if the environment is below 10°C because at this temperature, the rates of metabolism and diffusion are low.

**Aeration.** One approach in bioremediation is the complete oxidation of the organic pollutant to carbon dioxide, and this is generally associated with aerobic microbial metabolism. To promote O<sub>2</sub> as the electron acceptor, air containing 20.9 vol% oxygen is pumped into the area; this is referred to as *bioventing*. Usually this aeration results in the release of the volatile organic chemicals into the atmosphere and also promotes aerobic metabolism of bacteria. Alternately, the injection of hydrogen peroxide at a concentration of ≤500 mg/L has been used at bioremediation sites, with formation of gaseous oxygen from the reactions with minerals in the environment. Another possible bioremediation may involve piling of contaminated material on the soil surface with a plastic liner used to contain downward leaching of effluent. This pile or heap bioremediation system can be aerated, augmented with desired microorganisms, and supplemented with appropriate nutrients to optimize metabolism of the organic pollutant.

### 13.6 BIOREMEDIATION OF ORGANIC COMPOUNDS

Organic chemicals may enter the environment as wastestreams from industrial plants or as a result of environmental applications to control pests. Several industries use toxic organic compounds (see Table 13.1), and there is an interest in understanding the lifetime of hazardous chemicals in the natural environment. These compounds range in structural complexity from ones with a single carbon atom to complex heterocyclic structures (Swoboda-Colberg 1995).

The goal of bioremediation is the reduction of toxicity by modification of the organic molecule using enzymatic processes of aerobic and anaerobic microorganisms. Oxidation, reduction, and modification of toxic molecules are three major activities that microbes use. Reactions of oxidation occur when the organic compound is used as the carbon and energy source to support growth of bacteria, fungi, and yeast. With catabolism, mineralization may result with conversion of the organic molecule to carbon dioxide and inorganic salts. The initial step in the use of aromatic compounds is through monooxygenases or dioxygenases, where molecular oxygen is incorporated into the organic molecule. In reduction processes, anaerobic bacteria may use the organic compound as the terminal electron acceptor with another compound serving as the electron donor. An example of an anaerobic respiratory process includes dehalogenation of an organic molecule and reduction of nitroaromatics.

### 13.7 DEGRADATION OF HYDROCARBONS

Low-molecular-weight hydrocarbons include the *n*-alkanes, and while no single species is capable of oxidizing all *n*-alkanes, each microbial group is capable of metabolizing a

narrow range of these compounds for carbon and energy. Many microorganisms capable of utilizing *n*-alkanes have cytological changes with peroxisomes in yeast and intracytoplasmic membranes in bacteria (Radwan and Sorkhoh 1993). The bacteria recognized to grow on alkane oxidation include *Pseudomonas*, *Acinetobacter*, *Arthrobacter*, *Azospirillum*, *Corynebacterium*, *Mycobacterium*, *Nocardia*, and actinomycetes. While mesophilic *Bacillus* strains are not alkane degraders, *Bacillus stearothermophilus* grows on *n*-alkanes. Most studies on utilization of alkanes with yeast have been with *Candida*, *Lodderomyces*, *Rhodotorula*, and *Torulopsis*, while with filamentous fungi, *Aspergillus*, *Penicillium*, *Cunninghamella*, *Fusarium*, and *Cladosporium* have received the greatest attention. Additionally, anaerobic bacteria oxidize *n*-alkanes with a carbon chain of C<sub>6</sub>–C<sub>20</sub> and *n*-1-alkenes, with chains containing C<sub>7</sub>–C<sub>23</sub>, as electron donors and sulfate as the electron acceptor (Widdel et al. 2007).

### 13.7.1 Oil Spills

The petroleum industry is very large, and several situations may result in the release of hydrocarbons into the environment. At the oilfield sites there are surface impoundments originating from facility operations. Underground storage tanks may degrade over decades, and fuel hydrocarbons may leak into the soil or groundwater. There are thousands of oil spills annually in the United States, and while most of these are small, the cumulative annual spills may exceed several million gallons. At the global level, the oil spills attracting the greatest attention are those involving tanker wrecks, blowout oil wells, and oil releases. Some of the largest oil spills are listed in Table 13.2. In aquatic ecosystems, hydrocarbon degradation is attributed to bacteria and yeast, while fungi and bacteria are most important in remediation of contaminated soil. Immediately after a spill, the volatile hydrocarbons evaporate and microorganisms in the environment start decomposition of the nonvolatile aliphatic and aromatic hydrocarbons. Bioaugmentation and biostimulation are two approaches to bioremediation of oil spills. If the environment where the oil spill occurs has low microbial activity, it is useful to introduce organisms from an area where oil remediation is occurring, and this would be bioaugmentation. The number of bacteria degrading hydrocarbons will markedly increase as bioremediation of oil progresses; however, the abundance of organisms added in bioaugmentation will diminish as the oil disappears because the added organisms have difficulty in competing with the indigenous microorganisms. Biostimulation is the addition of nitrogen, phosphorus, and a surfactant to provide nutrients that support the microbial growth on the petroleum hydrocarbons. The rate of hydrocarbon decomposition is slower under anaerobic conditions, so it is important to aerate the environment of the oil spill.

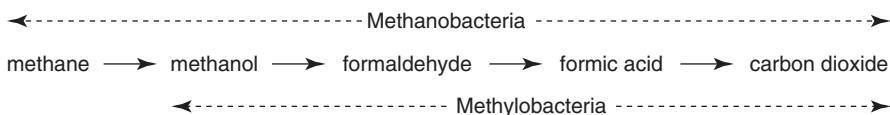
### 13.7.2 Methane Utilization

Methane is present in natural gas, coal formations, and anaerobic marshes or mud. The utilization of single-carbon compounds for energy is associated with several aerobic microorganisms. Methanobacteria oxidize methane to carbon dioxide by a series of steps involving methanol, formaldehyde, and formic acid as intermediates. Methylobacteria oxidize methanol to carbon dioxide but are unable to utilize methane.

TABLE 13.2. Some of the Worst Spills in the Oil Industry

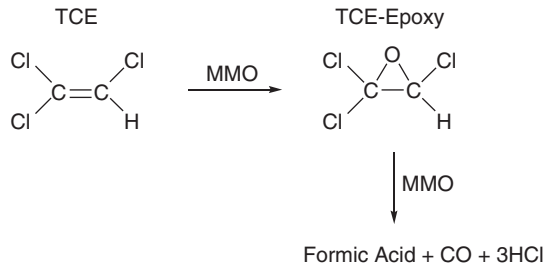
Spill Size (million gallons)	year	Tanker/Release	Location
380–520	1991	Release ordered by Saddam Hussein	Arabian Gulf/Kuwait
140	1979	Blowout of <i>Ixroc 1</i> offshore oil rig	Gulf of Mexico near Campeche, Mexico
90	1979	<i>Atlantic Express</i> tanker	Near Trinidad and Tobago
84	1994	Collapse of dike containing oil from leaking pipeline	Kolva River, Russia/Arctic Ocean
80	1983	Tanker hits platform	Nowruz Oil Field in the Persian Gulf, Iran
78	1983	<i>Castillo de Beliver</i> tanker	Off the coast of Cape Town, South Africa
69	1978	<i>Amoco Cadiz</i> tanker	Coast of Brittany, France
50–80	1978	<i>ABT Summer</i> tanker	Off the coast of Angola
45	1991	<i>MT Haven</i> tanker	Mediterranean coast near Genoa, Italy and southern France
41	1988	<i>Odyssey</i> tanker	Off the coast of Newfoundland, Canada
11	1989	<i>Exxon Valdez</i> tanker	Prince William Sound, Alaska
250 <sup>a</sup>	2010	Blowout of British Petroleum (BP) oil well	Gulf of Mexico near Louisiana

<sup>a</sup>Estimated.



Since the biological production of methane and methanol is attributed to anaerobic microbial metabolism, methanobacteria and methylobacteria are found in nature near the aerobic–anoxic interface. Methane-oxidizing bacteria are found in the Gammaproteobacteria (type I) as well as in the Alphaproteobacteria (type II) species. A major distinction of these two types of methanotroph is a pathway used to assimilate the carbon atom into cellular biomass (Barton 2005). Type I bacteria use the ribulose monophosphate cycle, while those of type II use the serine pathway. The key enzyme for methane oxidation to methanol is methane monooxygenase (MMO), which is found as a soluble enzyme and as a membrane-bound enzyme. The soluble MMO is capable of using over a hundred different substrates, including chlorinated hydrocarbons and epoxides that are highly toxic (see Figure 13.4).

Methylobacteria grow by converting methanol to formaldehyde by means of a methanol dehydrogenase. This enzyme is capable of oxidizing several primary alcohols in addition to methanol. Formaldehyde is oxidized to formic acid by a formaldehyde dehydrogenase, and formaldehyde is the only carbon structure in the methylobacteria or methanobacteria that is diverted into cellular material. Finally, formic acid is converted



**Figure 13.4.** Trichloroethylene (TCE) oxidation by monomethane oxygenase (MMO).

to carbon dioxide by the enzyme formate dehydrogenase, and reducing activity from this reaction is used by the bacteria for energy production. Bacteria with methylotrophy are found in the Alpha-, Beta-, and Gammaproteobacteria groups of Bacteria.

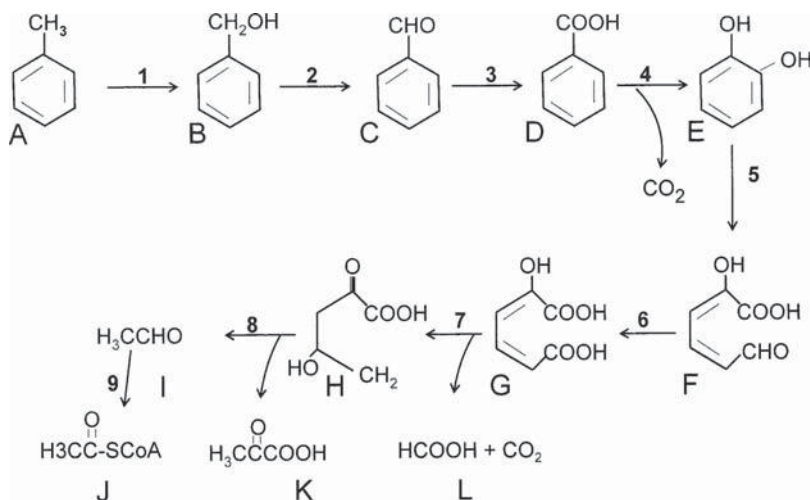
### 13.7.3 Fuel Hydrocarbons

Gasoline contains approximately 70% saturated hydrocarbons, which are highly volatile and quickly dissipate when a fuel spill occurs. Benzene, toluene, ethylbenzene, and xylene (BTEX) are residual compounds that are degraded by several different microorganisms, and some of most commonly studied systems are listed in Table 13.3.

Depending on the microorganism, aerobic degradation of toluene involves either a monooxygenase or a dioxygenase (see Figure 13.5) (Parales et al. 2008). With both the

**TABLE 13.3.** Microbial Degradation of Toluene

Microorganism	Characteristics	End Products
<b>Aerobic bacteria</b>		
<i>Pseudomonas putida</i> F1	Uses toluene dioxygenase	Succinyl-CoA + acetyl-CoA
<i>Burkholderia vietnamiensis</i> G4	Toluene-2-monooxygenase	Acetyl-CoA + pyruvic acid
<i>Ralstonia pickettii</i> PKO1	Toluene-3-monooxidase	Acetyl-CoA + pyruvic acid
<i>Pseudomonas mendocina</i> KR3	Toluene-4-monooxygenase	Succinly-CoA + acetyl-CoA
<i>Burkholderia</i> sp. strain JS150	Multiple toluene degradation with 5 toluene/benzene monooxygenase enzymes	Substrates for the TCA cycle
<i>Pseudomonas stutzeri</i> OX1	Toluene monooxygenase produces all 3 isomers of cresol	Substrates for the TCA cycle
<i>Pseudomonas putida</i> MT-2	TOL system with xylene monooxygenase	Pyruvic acid + acetyl-CoA
<b>Aerobic fungi</b>		
<i>Cladophialophora</i> sp. and <i>Exophiala</i> sp.	Toluene monooxygenase using cytochrome P450	Succinly-CoA + acetyl-CoA
<b>Anaerobic bacteria</b>	Addition of fumarate to methyl group of toluene	Acetyl-CoA

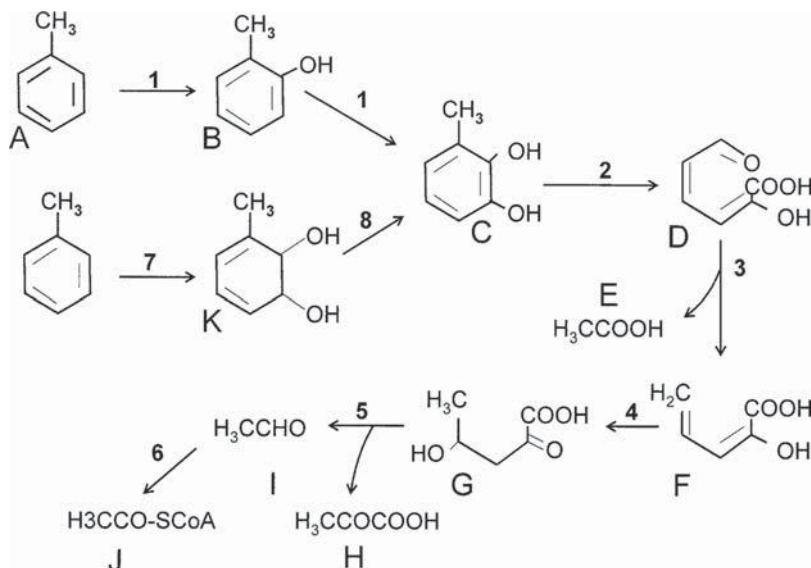


**Figure 13.5.** Toluene degradation by the TOL pathway in *Pseudomonas putida*. Structures are as follows: (A) toluene; (B) benzyl alcohol; (C) benzaldehyde; (D) benzoic acid; (E) catechol; (F) 2-hydroxymuconic semialdehyde; (G) 2-oxohex-4-ene-1,6-dioic acid; (H) 4-hydroxy-2-oxovaleric acid lyase; (I) acetaldehyde, (J) acetyl-CoA; (K) pyruvic acid; (L) formic acid. Enzymes are as follows: (1) xylene monooxygenase; (2) benzyl alcohol dehydrogenase; (3) benzaldehyde dehydrogenase; (4) toluate dioxygenase; (5) catechol 2,3-dioxygenase; (6) 2-hydroxymuconic semialdehyde dehydrogenase; (7) 4-oxalocrotonate tautomerase, 4-oxalocrotonate decarboxylase, and 2-oxopent-4-enoate hydrolase; (8) 4-hydroxy-2-oxovalerate aldolase; (9) aldehyde dehydrogenase.

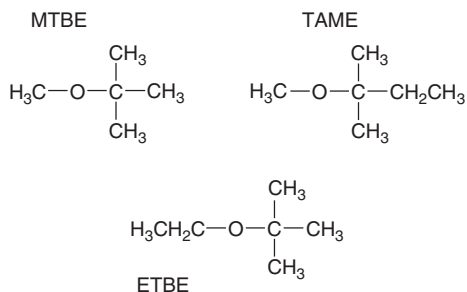
monooxygenase and the dioxygenase, toluene is oxidized to a catechol and following ring cleavage, the catabolic products are appropriate for the tricarboxylic acid (TCA) cycle. The toluene dioxygenase produced by *Pseudomonas putida* F1 is nonspecific and can oxidize over 100 different substrates, including all BTEX chemicals. There are several different monooxygenase systems in bacteria, where the enzyme refers to the location of the hydroxyl added to toluene (see Table 13.3). The compound containing a hydroxyl added to the ring of toluene is cresol. A toluene-2-monooxygenase oxidizes toluene to *o*-cresol, which is also the substrate for the toluene-2-monooxygenase to produce 2-methylcatechol. The toluene-3-monooxygenase produces *m*-cresol, and the toluene-4-monooxygenase produces *p*-cresol. There is a nonspecific toluene monooxygenase that randomly produces all three isomers of cresol. One of the plasmid systems used for toluene oxidation is the TOL system of *Pseudomonas putida* MT-2. The TOL plasmid contains two operons, with one gene cluster encoding for the oxidation of methylbenzenes to benzoates, and the other gene cluster is responsible for degradation of benzoates to acetate, pyruvate, and acetaldehyde. The pathway for toluene oxidation is given in Figure 13.6. The initial enzyme for oxidation of toluene by the TOL system is xylene monooxygenase, which also recognizes compounds structurally similar to toluene and xylene as substrates. Several fungal isolates oxidize toluene, and most of these are species of the genera *Cladophialophora* and *Exophiala*. These fungi use a monooxygenase enzyme to initially oxidize by a system similar to the TOL system, except the electron carrier is the cytochrome P450.

The anaerobic degradation of toluene by bacteria is achieved without oxygenase activity. As reviewed by Parales et al. (2008), the initial step is addition of fumarate to the





**Figure 13.6.** Pathways for monooxygenase and dioxygenase degradation of toluene. Structures are as follows: (A) toluene, (B) *o*-cresol, (C) 3-methylcatechol, (D) 2-hydroxy-6-oxohepta-2,4-dienoic acid; (E) acetic acid; (F) 2-hydroxypenta-2,4-dienoic acid; (G) 4-hydroxy-2-oxovaleric acid; (H) pyruvic acid; (I) acetaldehyde; (J) acetyl-CoA; (K) toluene *cis*-dihydrodiol. Enzymes are as follows: (1) toluene-2-monooxygenase; (2) catechol-2,3-dioxygenase; (3) 2-hydroxyl-6-oxohepta-2,4-dienoate hydrolase; (4) 2-hydroxypenta-2,4-dienoate hydratase; (5) 4-hydroxy-2-oxovaleric acid lyase; (6) acetaldehyde dehydrogenase; (7) toluene 2,3-dioxygenase; (8) toluene *cis*-dihydrodiol dehydrogenase.



**Figure 13.7.** Structures of fuel oxygenates. MTBE, TAME, and ETBE.

methyl of toluene, and following a series of reduction steps, acetyl-CoA is released. The best studied anaerobes involved in toluene oxidation include *Thauera aromatica* K172 and *T. aromatica* T1, *Azoarcus* sp. strain EbN1, and *Azoarcus* sp. T with nitrate as the electron acceptor. Other anaerobes that use toluene for growth include methanogenic consortia and the phototroph *Blastochloris sulfovirdis*. Under conditions of iron reduction, several species of *Geobacter* metabolize petroleum aromatic hydrocarbons. Species of *Desulfobacula*, *Desulfosarcina*, and *Desulfobacterium* couple the oxidation of toluene, xylene, and ethylbenzene with the reduction of sulfate (Widdel et al. 2007). Additionally, several species of bacteria oxidize naphthalene under sulfate-reducing conditions.

**Microbial Spotlight****LILY YOUNG**

Environmental disasters can lead to great leaps forward in research. Gas prices rising to \$1.20 per gallon during the first oil crisis in the mid-1970s first sparked Lily Young's interest in bioremediation. The problem was to convert landfill waste to something useful, like methane. Lily targeted lignin, a complex and difficult to degrade compound:

My role as the microbiologist [working with engineers] was to take the lignin breakdown products, and convert them to methane. Up until then, the only known organisms that could break down lignin were the white rot fungi. This got me into this area, where we could show that aromatic compounds were degraded by anaerobic microorganisms to CO<sub>2</sub> and methane.

Then we moved to the polycyclic hydrocarbons. I didn't think that polycyclic compounds could be degraded, and when we saw the data . . . the results showed that there was activity; it was absolutely clear. [Lily thought: "It's" got to be at the expense of this carbon source; Oh man, this is really cool! . . . and unexpected. Shows our ecosystem has surprises for us.

One of the unexpected small things that turned into something big during this research was a modification by Lily's graduate student, Joe Healy, of Terry Miller's work, who developed a method that showed that serum bottles could be used to

study anaerobic processes. “Joe took this idea and did many different selective enrichments. It was so much easier . . . and revolutionary. All the microbiologists do this now—it was this little methods paper that transformed the field.”

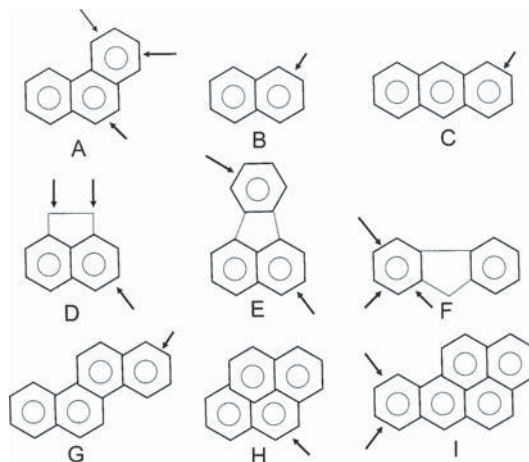
When Lily contemplates her research, she says:

It’s the sense of discovery that makes it fun. If you have an interesting project and you’ve looked at the literature and understood what others have done and you know what you want to look at. What’s really exciting is to realize that you would be the first person to determine this. This is what research is about—understanding something new that hasn’t been understood before. How do we understand this better? That goes back to the aromatics—the fact that they could be degraded anaerobically opened up a whole new doorway, not just the one question you’re asking, but a doorway to lots of questions to be asked. You’re moving the boundary forward.

When gasoline became lead-free, methyl (*tert*)-tertiary butyl ether (MTBE) was added to enhance octane and oxygenate fuel, which reduced the level of carbon monoxide emissions. As a result of leaks and spills of gasoline into the environment, the presence of MTBE in groundwater and lakes became an environmental problem by the year 2000. Although liquid MTBE is highly volatile, it is more soluble in water than aromatic hydrocarbons are and cannot be removed from contaminated water by air stripping. Since MTBE is highly mobile in groundwater and expensive to remove by chemical methods, there is considerable interest in bioremediation to detoxify MTBE-contaminated sites. As reviewed by Häggblom et al. (2007), aerobic degradation of MTBE is attributed to microorganisms containing methane monooxygenase, toluene monooxygenase, toluene dioxygenase, cytochrome P450 monooxygenase, propane monooxygenase, ammonium monooxygenase, or propylene monooxygenase. Under anaerobic conditions, MTBE is degraded under methanogenic, sulfate-reducing, nitrate-reducing, manganese-reducing, and iron-reducing conditions (Häggblom et al. 2007). Degradation of MTBE by bacteria in aerobic and anaerobic conditions results in the production of *tert*-butylalcohol and formic acid. Contamination attributed to MTBE has become sufficiently acute that it is limited or banned in most regions and in some areas is being replaced with ethanol, ethyl *tert*-butyl ether (ETBE), and *tert*-amylmethyl ether (TAME). More recently it has been observed that microbial cultures capable of degrading MTBE can also metabolize TAME. Structures of these ethers are given in Figure 13.7. In cases where ethanol-enriched gasoline is present in groundwater, BTEX compounds are not degraded until microbial metabolism of ethanol has been completed.

#### 13.7.4 Polyaromatic Hydrocarbons

The natural source of polyaromatic hydrocarbons (PAHs) is petroleum, coal tars from coal gasification plants, and fossil fuels. PAHs persist in the environment for years because of low water solubility and their binding to clays in the environment. The USEPA has identified 16 PAH molecules as hazardous, and a few of the structures are shown in Figure 13.8. Generally pentachlorophenol and dioxins are also present in PAH-contaminated sites. Various bacteria, algae, and fungi slowly degrade acenaphthene, anthracene, fluorine, phanathrene,



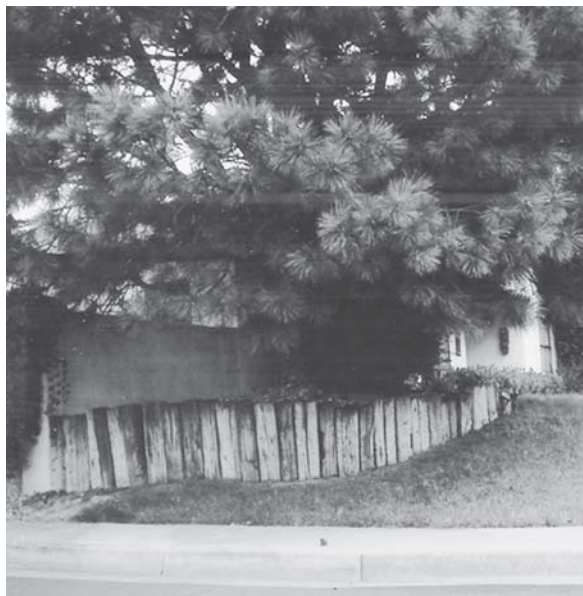
**Figure 13.8.** Structures of common polyaromatic hydrocarbon molecules. Molecules are as follows: (A) phenanthrene; (B) naphthalene; (C) anthracene; (D) acenaphthene; (E) fluoranthene; (F) fluorene; (G) chrysene; (H) pyrene; (I) benzo(a)pyrene. Arrows indicate point where enzymatic ring cleavage occurs.

fluoranthrene, and pyrene, while relatively little biodegradation occurs with chrysene, benz(a)anthracene, or benzo(a)pyrene. Metabolism of PAHs is correlated with aqueous solubility; solubility is required for degradation. Bacteria and *Selenastrum capricornutum*, a green alga, degrade PAHs with substrate-specific dioxygenases with the production of catechols and dihydrodiols. Bacterial metabolism of PAHs results in ring cleavage with intermediate uses as carbon sources for cell growth. *Phanerochaete chrysosporium*, *Trametes versicolor*, and *Bjerkandera* sp. and other white rot fungi use extracellular lignin-degrading peroxidases to mineralize PAHs to carbon dioxide. White rot fungi use enzymes that are not specific for a substrate and do not require specific nutrients for induction of lignin-degrading enzymes. Nonlignolytic fungi use membrane-bound monooxygenases to produce phenols, quinones, and various intermediates without release of carbon dioxide.

For years railroad ties and wooden poles have been treated with creosote to prevent microbial decay when placed in the ground. Creosote is a crude fraction of coal tar containing various PAH and related molecules that are not readily metabolized by soil bacteria and fungi. Frequently these creosote-saturated railroad ties are used for landscaping (see Figure 13.9). Soil near the railroad ties contain appreciable levels of PAH-degrading bacteria; however, the low solubility of PAH molecules in water greatly hinders the bacteria from decomposing PAH compounds. Coal tars are also found in shoe polish and account for the protection of leather when polish is employed. However, white rot fungi will degrade materials in shoe polish, and visible growth will become obvious after considerable time (see Figure 13.10).

### 13.8 DEGRADATION OF XENOBIOTICS

While there are several million different organic compounds in our biosphere, about a thousand new xenobiotic molecules are being synthesized each year (Sarokin 1988). Most of the xenobiotics created are never released into the environment, but those compounds



**Figure 13.9.** Railroad ties are used in landscaping because the creosote treatment retards microbial growth. See insert for color representation.



**Figure 13.10.** Colonies of fungal growth on the surface of shoe polish.

that are used as pesticides, food dyes, cleaning solvents, or explosives may present problems in the environment. Many of the xenobiotic chemicals are persistent organic pollutants (POPs) because they are not reactive under standard conditions and reside in soil for many years because they are of low water solubility and because of their attachment to clay. As indicated in Table 13.4, several POPs persist in the environment for weeks to years. While scientists are pursuing studies to increase the rates of POP degradation by microorganisms, there is another group of synthetic compounds that are completely resistant to microbial degradation. Some examples are as follows:

- Dacron—poly(tethylene glycol)terephtholate
- Estron—acetate rayon
- Nylon—polyester  $[-\text{NH}-\text{!OC}(\text{CH}_2)_x-\text{CO}-]_n$
- Orlon—polyacrylonitrile
- Polyethylene— $(-\text{CH}_2-\text{CH}_2-)_n$

TABLE 13.4. Chemicals Categorized According to Toxicity and Persistence in the Environment

Highest Level of Concern	Persistence	Moderate Level of Concern	Persistence
<i>Insecticides</i>		<i>Pesticides</i>	
Aldrin	3 years	Chlordecone	?
Chlordane	5–16 years	2,4-Dinitrophenol	?
Mirez	12 years	Dicofol	?
Dieldrin	21 years	Heptachlor	2 years
Toxaphene	16 years	Lindane	3 years
DDT	4–21 years	Pentachlorophenol	?
Endrin	16 years	Picloran	?
Heptachlor	2–16 years	Parathion	1 week
		Malathion	1 week
<i>Other Organic Compounds</i>		<i>Other Organic Compounds</i>	
PCPs	Years	Polyaromatic hydrocarbons	Decades
		2,4-Dichlorophenoxy acetic acid (24-D)	4–12 weeks
		2,4,5-Trichlorophenoxy acetic acid	2–3 years
		Textile dyes	

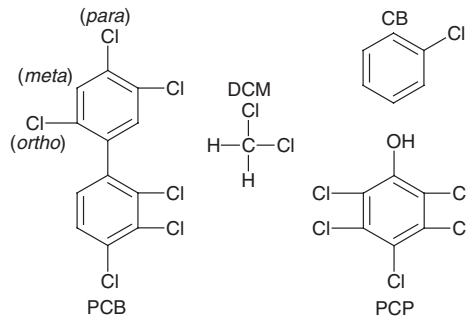
Sources: Alexander (1994); Madigan et al. (2009).

- Polystyrene— $[-\text{CH}_2-\text{CH}(\text{C}_6\text{H}_5)]_n$
- Polyurethane— $(-\text{R}_1-\text{NH}-\text{CO}-\text{O}-\text{R}_2-)_n$
- Polyvinyl chloride (PVC)— $(-\text{CH}=\text{CCl}-)_n$
- Saran—vinylidene chloride–vinyl chloride copolymer
- Silicone resins— $(\text{R}-\text{Si}-\text{O}-)_n$
- Teflon— $(-\text{CF}_2-\text{CF}_2-)_n$

### 13.8.1 Detoxification of Chlorinated Organic Compounds

There are a series of low-molecular-weight organic compounds that contain chloride and are degraded by various microorganisms. Included in this category would be chlorobenzene, chlorobiphenyls, chloroanilins, carbon tetrachloride, and chloroform (see Figure 13.11). Aerobic microorganisms use many linear carbon chain and aromatic chlorides, including vinylchloride, 1,2-dichloroethane, chlorobenzene, monochlorobiphenyls, chlorobenzoates, and chlorophenols as a carbon source (Adriaens and Vogel 1995). Anaerobic bacteria have been demonstrated to use dichloromethane, chlorobenzene, and chlorophenols as a carbon source. The maximum decomposition with mineralization of the carbon compound occurs with trichloroethylene, chloroacetate, chloroform, and vinylchloride under cometabolism. Anaerobic bacteria reduce DDT, carbon tetrachloride, and chloroform with loss of chlorine, provided appropriate electron donors are present. Degradation of chlorinated organic compounds is often attributed to enzymes that are inducible and specific for a substrate. In some activities, the initial step in degradation of a chlorinated compound is attributed to activities that are relatively nonspecific. Oxidation by white rot fungi and peroxide-generating bacteria is not specific for a substrate because free radicals react with all compounds. Mineralization of chlorinated compounds proceeds most quickly in syntrophic communities.



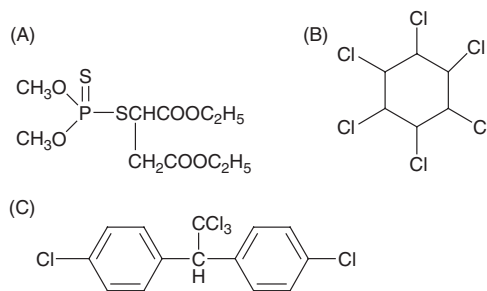


**Figure 13.11.** Examples of chlorinated hydrocarbons. Structures: PCB—2,3,4,2',4',5'-hexachlorobiphenyl; PCP—pentachlorophenol; DCM—dichloromethane; CB—chlorobenzene.

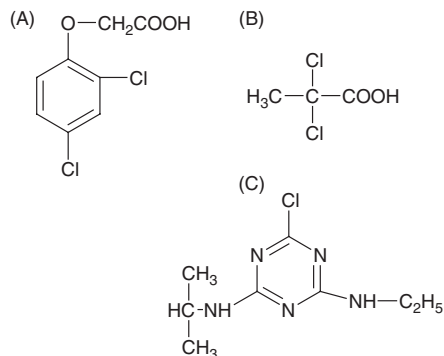
Poly(chlorinated biphenyl) (PCB) compounds have had wide industrial use as fluids in transformers, flame-retardant chemicals, solvents, and hydrolic fluids (Bedard and Quensen 1995). Depending on the location and number of chlorine molecules present, there are over 200 different PCBs, and most commercial products are a mixture of 50–90 different molecular configurations. Microorganisms are considered to be responsible for removal of chlorine atoms from the *meta* and *para* positions (Figure 13.11) on PCB molecules. Dichlorinated and *ortho*-chlorinated PCBs appear to be most resistant to microbial digestion. Decomposition of PCBs in sediments is attributed to environmental cultures of methanogens and sulfate-reducing bacteria.

### 13.8.2 Herbicides and Pesticides

Several anaerobic bacteria are capable of detoxifying organic compounds by a reductive process that uses the organic compound as the final electron acceptor. Examples of chlorinated compounds used as insecticides and herbicides are given in Figures 13.12 and 13.13, respectively. Enzymatic change of organic toxic pesticides and herbicides is a result of the following (Alexander 1994): (1) alternation of the size of the molecule by cleavage of ester or ether bonds by esterases and etherases, respectively; (2) elimination of a toxic unit by removal of  $-NF_2$  moieties by deamination reactions with replacement of chloride, bromide, fluoride, or iodide by a hydrogen atom in dehalogenation reactions; (3) addition of hydroxyl or methyl groups; (4) deletion of methyl or methoxy groups; and (5) conversion of a triple bond between a carbon atom and a nitrogen atom to a single



**Figure 13.12.** Examples of some chlorinated insecticides: (A) malathion; (B) lindane; (C) dichlorodiphenyltrichloroethane (DDT).

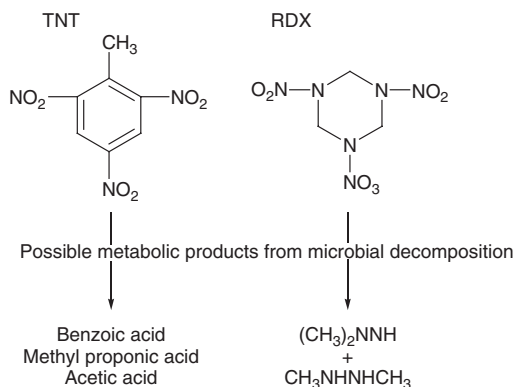


**Figure 13.13.** Structures of some chlorinated herbicides: (A) 2,4-D (2,4-dichlorophenoxyacetic acid); (B) dalapin; (C) atrazine.

bond. Other organic compounds are degraded by specific reductive processes such as the reduction of methacrylate to isobutyrate by the rumen anaerobe, *Wolinella succinogenes* (Gross et al. 2001).

### 13.8.3 Biodegradation of Explosives

Characteristically, organic explosives have nitro ( $-\text{NO}_2$ ) groups attached to ring structures. Historically, the most widely used explosive is trinitrotoluene (TNT), which is found as a contaminant in soils where ammunitions have been stored. Other explosives used include hexahydro-1,3,5-trinitro-1,3,4- triazine (RDX) and octhydro-1,3,5,7-tetranitro-1,3,5,7-triazine (HMX), and these are soil contaminants as well. The structures of TNE and RDX and their projected products of microbial metabolism are given in Figure 13.14. Nitroaromatic respiration by *Desulfobacterium* and *Desulfovibrio* occurs when 2,4,6-trinitrotoluene (TNT) and 2,6-dinitrotoluene are used as final electron acceptors (Boonpathy 2007). Under nitrogen-limited conditions, cultures of sulfate-reducing bacteria and *Veillonella alkalescens* reduce TNT to triaminotoluene before deamination is proposed to release ammonium. In an analogous reaction, *Desulfobacterium aniline* will reductively metabolize aniline to produce benzoic acid. The reduction of the nitro group



**Figure 13.14.** TNT and RDX structures with products of microbial degradation.

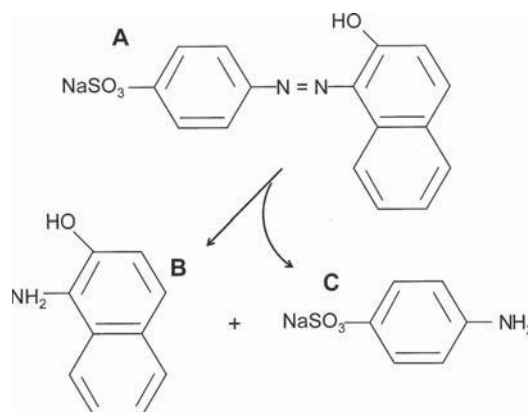
of TNT to amino moieties may be attributed to nitrite reductase, which is commonly found in anaerobic bacteria. When TNT is the carbon and energy source for *Desulfovibrio*, acetic acid is proposed as the product of catabolism. Anaerobic metabolism of TNT by *Clostridium bifermentans* has also been reported, and it is tentatively attributed to the fermentative capabilities of this obligate anaerobe (Staley et al. 2007).

Bioremediation is replacing incineration of soil and lagoon sediments at military installations contaminated with TNT, RDX, and HMX. A composting process has been useful in remediation of explosives-contaminated soil, and field demonstrations have been conducted at several sites (Keehan and Sisk 1996). The compost pile consisted of contaminated material, straw, alfalfa hay, fertilizer, and animal manure. After several months with continuous aeration at 55°C, the mixed microbial system reduced the level of explosives by over 99% and no toxicity was associated with metabolic end products.

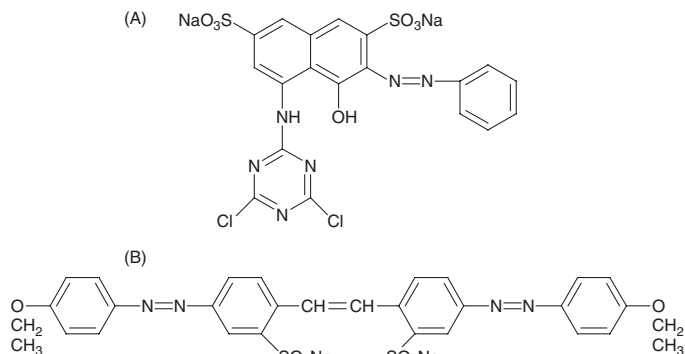
### 13.8.4 Decomposition of Textile Dyes

Almost a million tons of dyes are produced annually for global distribution in the world market for the textile industry. These dyes are primarily of the azo ( $-N=N-$ ) class, which are used to color cellulose, wool, polyester, and acrylic fibers. Reactive Red 2 (Figure 13.15), Acid Orange 7, and Reactive Red 2 (Figure 13.16) are examples of azo textile dyes that may enter the environment primarily from textile dye facilities, and the concentration may be several milligrams of dye per each liter of discharged water. While the toxicity of these textile dyes is relatively low, there is an effort to safeguard the environment from these brightly colored wastewaters. Various chemical and physical methods have been developed to remove dye from water; however, these methods are expensive. For decades it has been known that food dyes, including azo dyes, are metabolized by the liver, kidneys, and intestinal bacteria. Aromatic amines are decomposition products of azo dyes and are excreted in urine. Bioremediation of water contaminated with textile dyes may employ several different approaches.

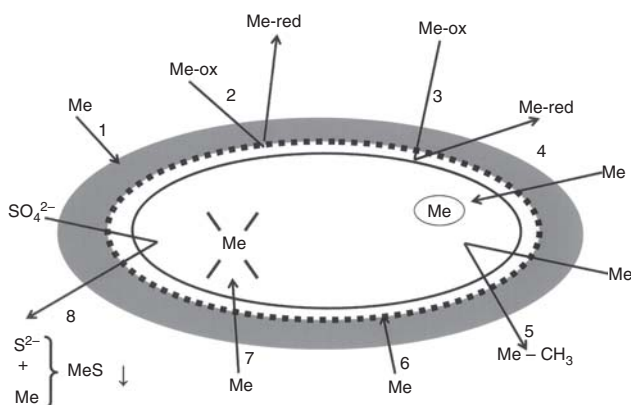
One mechanism of dye decomposition is attributed to peroxidase activity of various fungi and a few bacteria. Mineralization of azo dyes to carbon dioxide has been reported for ligninolytic fungi, including *Phanerochaete chrysosporium*, *Trametes versicolor*, *Pycnoporus cinnabarinus*, and *Pyricularia oryzae* (Schliephake et al. 2000). Examples of



**Figure 13.15.** Reduction of Acid Orange 7, a monoazo dye: (A) Acid Orange 7, (B) 1-amino-2-naphthol; and (C) sulfanilic acid.

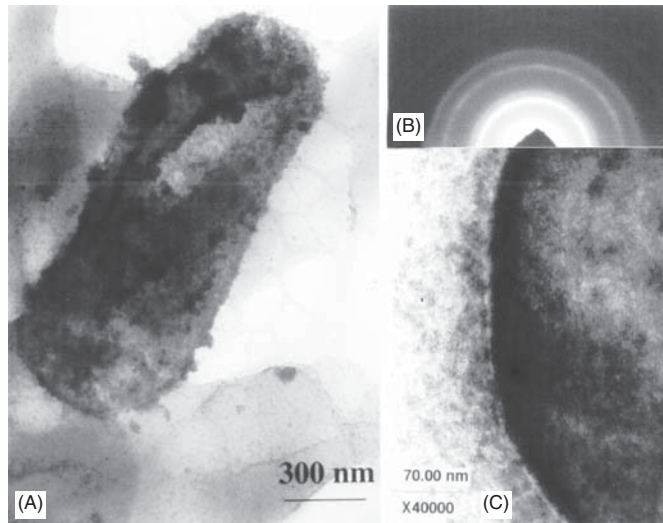


**Figure 13.16.** Structures of azo dyes: (A) Reactive Red 2; (B) Direct Yellow 12.



**Figure 13.17.** Model indicating microbe–metal interactions. Activities as follows: (1) metal ions binding to the capsule or cell surface; (2) oxidized metal ion reduced at the outer membrane with release of the reduced metal; (3) oxidized metal ion reduced by cytochrome in the periplasm; (4) metal and metalloid ions transported into the cell where it becomes localized; (5) metal and metalloid ions are methylated by cytoplasmic enzymes; (6) metal ions are bound onto the surface of the outer membrane; (7) metal ions are transported into the cell by siderophores; (8) metals are reduced and precipitated as a metal sulfide with sulfide produced from bacterial sulfate reduction.

peroxidase-producing bacteria that degrade azo dyes include *Streptomyces chromofuscus* and *Sphingomonas chlorophenolicus*; however, these bacterial cultures do not mineralize the dyes to carbon dioxide (Pasczynski et al. 1992). Several factors suggest that lignin-degrading fungi would not be useful as bioremediation agents of azo dyes in wastewater, including the following: (1) there is a limited distribution and abundance of peroxide-generating microorganisms in running water, (2) the process requires several days for decolorization because genes for lignin degradation (i.e., peroxide generation) are generally produced under nitrogen-limited conditions and are associated with secondary metabolism, (3) there is a lack of specificity of the peroxide for azo dyes with other materials in the wastewater competing for the oxidative radicals produced, and (4) there is a requirement of pH 4.5–5 for optimal dye reduction.



**Figure 13.18.** Reduction of U(VI) to U(IV) by *Desulfovibrio desulfuricans*: (A) the site of U(IV) deposited on the cell is reflected in the dark regions; (B) crystalline organization of U(VI) deposits indicated by electron probe analysis; (C) thin section of bacterial cell reveals the presence of U(VI) localized in the extracellular matrix (photographs provided by Larry Barton).

High levels of azo dyes are decolorized by anaerobic bacteria, and this activity is appropriate for bioremediation efforts. Various cultures of anaerobic bacteria decolorize dyes with flavin reductases proposed to function in a nonspecific fashion as azoreductases (Russ et al. 2000). Enrichment cultures from sewage sludge as species of *Clostridium*, *Eubacterium*, *Bacteroides*, *Proteus*, and *Enterococcus* reduce azo dyes under conditions of cometabolism (Stolz 2001). Several dyes, including Reactive Red, Reactive Black, and Reactive Brilliant Violet, are reduced in biodigestors under sulfidogenic conditions.  $H_2S$ , produced by microbial metabolism, cleaves the azo dyes to produce aromatic amines. *Shewanella decolorationis* uses amaranth, an azo dye, as the final electron acceptor (Hong et al. 2007), and it is possible that sulfate-reducing bacteria and methanogenic archaea may also reduce azo dyes present in textile wastewaters. Anaerobic bacteria are not as effective as aerobic microorganisms in mineralizing aromatic amines that are produced by anaerobic metabolism of azo dyes. Thus, a biological treatment system for azo dyes would appropriately consist of an initial anaerobic phase followed by another set of bacteria growing under aerobic conditions.

### 13.9 BIOREMEDIATION WITH INORGANIC POLLUTANTS

Remediation of soil or groundwater contaminated with toxic metals is a challenge because, unlike organic pollution, the metals remain in the environment. A result of microbial metabolism of soluble toxic metals may become immobilized or reduced to a less toxic oxidation state. There is always the possibility that, under appropriate environmental conditions, the immobilized or reduced metals may be oxidized and released as a soluble toxic ion into the environment.

### 13.9.1 Microbe–Toxic Metal Interactions

As cells of microorganisms grow, they are exposed to various water-soluble metals in the environment. The general interaction of metals with bacteria is shown in Figure 13.17. The microbes are exposed to metal ions that are needed in trace levels for growth, but at elevated levels the metal ions are toxic to microbial cells. Alternately there may be metal ions in the water that are not required for growth, and their presence is always detrimental to microbial cells. Several different activities are displayed by microorganisms, but these microbe–metal interactions generally are aligned with either of two processes. In one case, microorganisms reduce the concentration of toxic metal ions in the environment by cellular binding, which is also known as *bioaccumulation*. A second mechanism relies on cellular metabolism to change the soluble toxic metal ions to an insoluble form with reduced toxicity. The bioaccumulation process is passive in that it relies on binding affinities, while the metabolic activities are active and dependent on cell energetics. There are a few bioremediation processes where microorganisms are used to reduce the level of toxic metals in the environment. The following text provides information about some of the microbe–metal interactions.

**Cytoplasmic Detoxification of Metals.** Both prokaryotic and eukaryotic microorganisms require metal cations (e.g., sodium, manganese, potassium, calcium, manganese, iron, cobalt, nickel, copper, zinc) for growth. The acquisition of these metals is by numerous uptake transport systems. Some of these importers lack specificity and will transport toxic metals or promote the uptake of essential cations to toxic levels. Metal homeostasis in the cytoplasm of fungi is maintained, in part, by vacuoles. Through the use of H<sup>+</sup>-driven ATPases, vacuoles detoxify the cytoplasm by sequestering ions of manganese, iron, zinc, cobalt, strontium, lithium, and cesium (Gadd and Sayer 2000). Increase in metal levels may have an effect on amino acid pools, as in the case where *Saccharomyces cerevisiae* uses histidine-containing vacuoles to bind cytoplasmic nickel. Because of the absence of comparable vacuoles in prokaryotes, bacteria rely heavily on exporter systems to prevent cytoplasmic accumulation of toxic metals (Silver and Phung 1996).

Another process for reducing toxic metals in the cytoplasm of microorganisms is the binding of cations by amino acids or low-molecular-weight peptides (Gadd and Sayer 2000). Metallothioneins are low-molecular-weight proteins containing a high concentration of cysteine residues, and in *Saccharomyces cerevisiae* and *Candida glabrata*, metallothioneins have a high affinity for copper and cadmium ions. A second class of metal-binding peptides have a structure derived from glutathione and are termed *phytochelatins*. The general structure of phytochelatins contains [(glutamic acid–cysteine)<sub>n</sub>–glycine], where the glutamic acid–cysteine dimer is repeated several times. While phytochelatins have not been demonstrated in prokaryotes, *Schizosaccharomyces pombe* and *Candida glabrata* produce phytochelatins with greatest affinity for binding cations of copper and cadmium (Penninckx and Elskens 1993).

Although phytochelatins have not been demonstrated in prokaryotes, metallothioneins or metallothionein-like proteins are present in bacteria. Several genera of cyanobacteria are capable of producing metallothioneins that function to bind Zn<sup>2+</sup>, Cd<sup>2+</sup>, Cu<sup>+</sup>, and Ag<sup>+</sup>. The metallothionein from *Synechococcus* has only nine cysteine residues, while plant and animal systems have 12 and 20, respectively. A zinc-binding metallothionein has been demonstrated in *Anabaena*, *Pseudomonas aeruginosa*, and *Pseudomonas putida*, while several bacteria have metallothionein-like proteins (Bindauer et al. 2000).



A copper-binding metallothionein has been isolated from *Mycobacterium tuberculosis* (Gold et al. 2008). Although patents have been received for processes using metallothionein to remove toxic metals from water, functional demonstrations have not been produced.

**Binding of Metals by Cells and Capsules.** Immobilization is an important process for microbial cells to detoxify an environment of metals. The cell wall of dead microbial cells binds cationic metals because acidic sugars, amino acids, and heteropolysaccharides containing phosphate make up the cell wall structure. The binding by dead cells is similar to ion exchange resins; however, microbial cells are more effective than chemical resins. After metals are sorbed on the cell biomass, metals can be desorbed from the cells with acid or base, and the biomass can be reused for several adsorption–desorption cycles. Pellets of *Aspergillus oryzae* have been used to remove Cd from wastewater, and packed cells of *Trichoderma viridie* have been demonstrated to remove Cu from effluents (Gadd 1990). Immobilized particles of *Aspergillus niger* in a fluidized-bed reactor have been effective in  $\text{UO}_2^{2+}$  removal. With adjustment of the pH of the wastewater, dried algal and cyanobacterial cells are capable of binding many different cationic and anionic metals. Dried cells of *Chlorella vulgaris*, *Cyanidium caldarium*, *Macrocystis pyrifera*, *Spirulina platensis*, *Sargassum natans*, and *Eisenia bicyclis* have been found effective in binding various metals ions, and selective elution of metals from these cells can be achieved (Greene and Darnell 1990). Cells of a *Bacillus* have been effective in removing cations from water systems, but the economics of the system may not support its application (Brierley et al. 1986). Dead cells have compromised membranes, and metal ions may diffuse into the cytoplasm and bind to negatively charged polyphosphates or macromolecules of RNA and DNA.

Bacterial capsules and extracellular polysaccharide matrix (EPM) materials are also effective in binding metals. Capsule production is a unique activity associated primarily with prokaryotic organisms, and considerable diversity exists in terms of chemical composition (Barton 2005). Capsules of cyanobacteria, *Azotobacter*, and *Pseudomonas* species contain uronic acids (sugar acids) while several *Bacillus* species have capsules that are polymers of glutamic acid. Also present in bacterial capsules are pyruvic acid, amino acids, and aminosugars. Various metal ions have an affinity for adjacent hydroxyl groups found on sugars. These capsules are a water-filled structure that may extend 10  $\mu\text{m}$  from the cell wall and thus interface with the environment. As a result of the various charge interactions, 25% of the capsule mass may be metals. While a biotechnology process does not deal exclusively with capsular material, the procedures using dead bacterial cells will also have metal-binding activity of capsules (Geesey and Jang 1990). The EPM contains exopolysaccharide plus proteins and other materials of bacterial origin. This amorphous material binds and entraps various metallic compounds. Sulfate-reducing bacteria bind toxic metals in the EMP (see Figure 13.18).

**Reduction of Metals.** Several of the redox-active toxic elements are highly soluble in oxidized form and, therefore, microbial reduction to a less soluble form is desirable. As indicated in Table 13.5, anaerobic bacteria will reduce numerous metal and metalloid ions. In some cases, the reduction uses electrons from the respiratory system, and organisms involved in this process are dissimilatory metal-reducing bacteria (DMRB). Some bacteria have coupled cell growth with metal reduction and have specific metal reductases. Sulfate-reducing bacteria use periplasmic cytochromes and iron–sulfur proteins to nonspecifically

TABLE 13.5. Metals and Metalloids Reduced by Microorganisms<sup>a1</sup>

Metals	Oxidized	Reduced	Metalloids	Oxidized	Reduced
Chromium	Cr(VI), chromate	Cr(III)	Arsenic	As(V), arsenate	As(III), arsenite
Cobalt	Co(III)	Co(II)	Selenium	Se(VI), selenate	Se(0) ↓
Copper	Cu(II)	Cu(I)	Tellurium	Te(IV),	Te(0) ↓
Gold	Au(III)	Au(0) ↓			
Iron	Fe(III), ferric	Fe(II), ferrous			
Lead	Pb(II)	Pb(0) ↓			
Manganese	Mn(IV)	Mn(II)			
Mercury	Hg(II)	Hg(0) ↓			
Molybdenum	Mo(VI), molybdate	Mo(IV)			
Neptunium	Np(V)	Np(IV)			
Palladium	Pd(II)	Pd(0) ↓			
Plutonium	Pu(V)	Pu(IV)			
Silver	Ag(I)	Ag(0) ↓			
Technecium	Tc(VII), pertechnetate	Tc(IV)			
Uranium	U(VI), uranyl	U(IV), uranyl			
Vanadium	V(V)	V(III)			

<sup>a1</sup>Bacteria and archaea associated with these reductions are found in Lloyd (2005).

reduce uranium and chromium (Barton et al. 2003; Bruschi et al. 2007). Iron-reducing bacteria (e.g., *Shewanella* and *Geobacter*) reduce uranium (Lloyd et al. 2003) and other metals using cytochrome located in their outer membrane. Immobilization of reduced uranium and chromium results from the binding to the extracellular matrix produced by bacteria (see Figure 13.18). Using bioreactors where the parameters of microbial activities can be controlled, DMRB are effective in reducing many redox-active elements.

Metal reduction by anaerobic bacteria had been examined for environmental bioremediation of toxic metals. As proposed by Lovley (1995), DMRB could be applied to remediate uranium mill tailing sites. By providing a suitable electron donor of acetate or ethanol, DMRB could reduce soluble uranium(VI) to insoluble uranium(IV) and, thereby, detoxify the environment. Bioremediation studies of a uranium mill site at Rifle, Colorado (USA) indicated mixed results in terms of long-term reduction of soluble oxidized uranium (VI) (Anderson et al. 2003). Initially, the quantity of soluble uranium in groundwater decreased with an increase in the concentration of Fe(II) in groundwater and an increase in population density of *Geobacter*, but after a month, the amount of soluble uranium(VI) began to increase. This change in concentration of uranium(VI) occurred at the time sulfate concentration decreased, hydrogen sulfide levels increased and activity of sulfate-reducing bacteria increased. A contributing factor for the increase of uranium(VI) in groundwater may be the release of sorbed U(VI) onto particulate material by unexplained microbial or chemical consequences attributed to initiation of bioremediation.

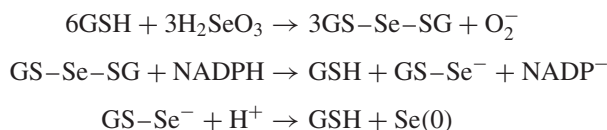
**Precipitation Reactions.** In addition to reduction of toxic metals by sulfate-reducing bacteria, these bacteria produce large quantities of hydrogen sulfide as an end product of respiration. As reviewed by Barton and Fauque (2009), sulfide produced by sulfate reducers to precipitate Zn, Pb, Cd, Cu, Ni, Cr, Fe, and Se has been used for bioremediation of acid mine drainage from abandoned mines. Various substrates were used as electron donors for these compost reactors or *in situ* reactive barriers for bioremediation of acid mine drainage. A commercial process, THIOPAQ<sup>®</sup>, is used in The Netherlands

to precipitate metal cations produced at a zinc refinery [see Hockin and Gadd (2007); Website is given at end of the chapter]. Electron donors for the production of 2.5 tons of H<sub>2</sub>S per day by sulfate-reducing bacteria include H<sub>2</sub>, ethanol, methanol, and natural gas. By control of pH in the recovery of metals, selective separation of arsenic from copper, copper from zinc, and iron from nickel can be achieved. Environmental toxicity is avoided because excess H<sub>2</sub>S is oxidized to elemental sulfur.

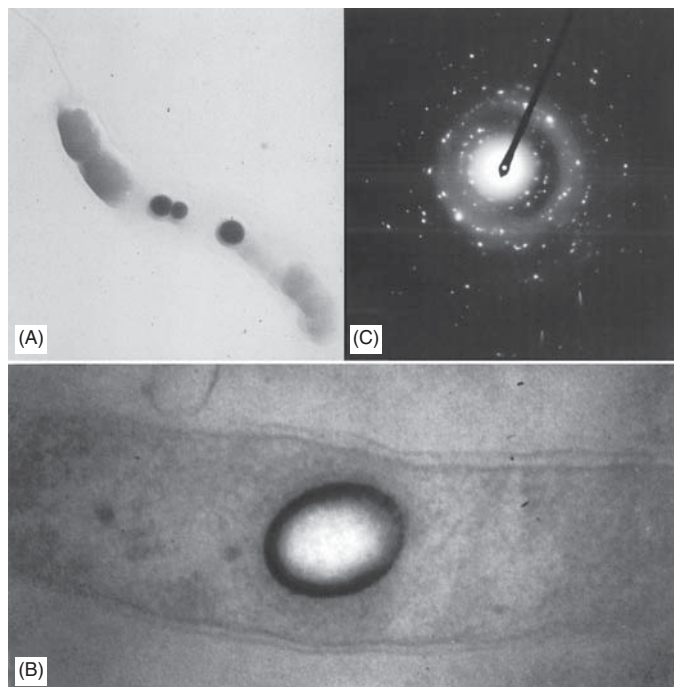
**Methylation of Metals and Metalloids.** Bacteria, archaea, and fungi use several different mechanisms to add methyl groups to produce mono-, di-, or trimethyl metals/metalloids (Ehrlich 2002). Methylation of metals and metalloids is achieved by various bacteria, including species of *Clostridium*, *Desulfovibrio*, *Pseudomonas*, *Bacillus*, *Escherichia*, and *Enterobacter*. Additionally, various fungi, including *Aspergillus niger*, *Saccharomyces cerevisiae*, and *Scopulariopsis brevicaulis*, methylate metals or metalloids. Microbial methylation has been reported for a large number of metals/metalloids, including mercury, cadmium, lead, tin, germanium, platinum, gold, tellurium, arsenic, antimony, and selenium. Frequently the quantity of methylated metal or metalloid accumulating in the environment is small. One of the features of metal bioremediation employing immobilization, precipitation, and reduction of metals/metalloids is that the element remains in the environment. Some consideration has been given to bioremediate toxic metals by forming methylated metals that would volatilize into the atmosphere. However, the methyl group would be oxidized in the atmosphere, and the oxidized metal or metalloid would fall back to Earth.

### 13.9.2 Detoxification of Selenium

Selenium is chemically similar to sulfur in that both have the same oxidation states (II, 0, IV, and VI) and the global cycle of selenium is similar to the sulfur cycle [see Stolz et al. (2006) and Section 10.6]. The importance of selenium as a nutritional required by animals is underscored by the fact that there is a specific codon (UGA) for selenocysteine-tRNA. Various organic compounds contain selenium, including volatile dimethylselenide. In semiarid environments, selenate concentration in drainage water may reach a toxic level, as evidenced by wildfowl death in the mid-1980s at the Kesterson Reservoir in California. At sublethal concentrations, various aerobic bacteria reduce selenate or selenite to Se(0) by reduced glutathione with intracellular accumulation of selenium as a granule (Zannoni et al. 2007). The participation of reduced glutathione (GSH) in formation of Se(0) ↓ is considered to follow the following reactions:



In the reaction between reduced glutathione and selenite, oxygen superoxide is produced, and this highly reactive oxygen species is degraded by the combined activity of catalase and superoxide dismutases. Glutathione reductase converts the glutathione-selenide-glutathione molecule to reduced glutathione, and glutathione-selenide will spontaneously degrade to elemental selenium in the presence of a proton. An electron micrograph of *Moraxella bovis* growing in the presence of



**Figure 13.19.** Reduction of selenite ( $\text{SeO}_3^{2-}$ ) to elemental selenium ( $\text{Se}^0$ ) by *Wolinella succinogenes* (photographs provided by Larry Barton).

selenite indicates the presence of an elemental selenium granule in the cytoplasm (Figure 13.19). Anaerobic bacteria also reduce selenate or selenite to elemental selenium; however, this reduction does not appear to involve reduced glutathione. In various species of *Desulfovibrio* and *Wolinella succinogenes*, the destruction of selenium oxyanions to elemental selenium is attributed to nonspecific reductases or cytochromes. Dissimilatory reduction of selenium is characteristic of *Bacillus arsenicoselenatis*, *Sulfurospirillum arsenophilum*, *Sulfurospirillum barnesii*, and *Thauera selenatis*, where these bacteria are capable of growing with selenium oxyanions serving as the electron acceptor with the production of elemental selenium (Stolz et al. 2006). A specific reductase for selenate has been identified for *Thauera selenatis*, and this enzyme accomplishes dissimilatory selenate reduction (Schroder et al. 1997).

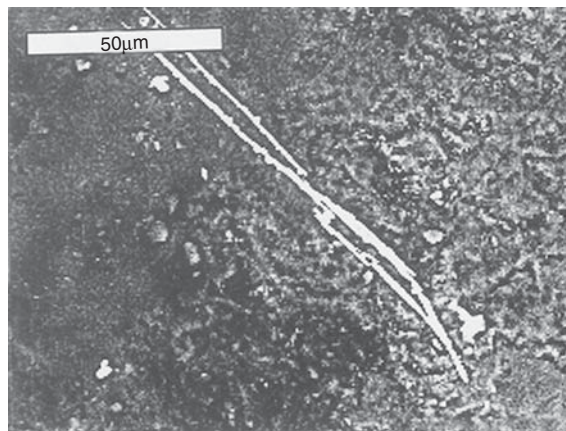
Bioremediation of soil and water containing selenate ( $\text{SeVI}$ ) and selenite ( $\text{SeIV}$ ) involves the reduction to amorphous red elemental  $\text{Se}(0)$ . A pilot-scale biofermentor using *Thauera selenatis* was used to remove 96% of selenate from drainage water at a flow rate of 7.6 L/min (Cantafo et al. 1996). While elemental selenium is markedly stable in aquatic systems (Zhang et al. 2004), it can be removed from water by the use of appropriate flocculating agents. If nitrate is also present in selenate-containing waters, denitrification proceeds before *Thauera selenatis* reduces selenate.

### 13.9.3 Reactions with Arsenic

Arsenic toxicity causes extreme health problems in animals, and if arsenic is ingested in appreciable levels, death will result. Arsenic contamination of the environment may result

from fumes emitted from industrial smelters, chemical manufacturing processes, and chemically treated wood used in landscaping. There is arsenic in poultry litter, and there is increasing concern that it may contribute to increased arsenic levels in fertilized soils. In certain regions of the world high levels of arsenic are present as a natural chemical in aquifers, and contamination of drinking water is extremely dangerous. Arsenic is found in minerals such as arsenopyrite ( $\text{FeAsS}$ ), and microbial oxidation results in production of As(III) and in some cases, arsenate. In aerobic biological systems, arsenate [ $\text{AsO}_4^{3-}$ , As(V)] competes with phosphate [ $\text{PO}_4^{3-}$ ; P(V)] in phosphorylation reactions with a decrease in ATP production. Under reducing conditions, arsenic is present as arsenite [ $\text{AsO}_3^{3-}$ , As(III)] and in highly reducing environments, as arsine ( $\text{AsH}_3$ ). Microorganisms have been demonstrated to participate in arsenate reduction and formation (Stolz et al. 2006; Santini et al. 2000). *Sulfospirillum barnesii*, *Sulfospirillum arsenophilum*, *Desulfotomaculum auripigmentum*, and *Chrysuigenes arsenatis* grow by coupling energy production with reduction of As(V) to As(III). The formation of solid  $\text{As}_2\text{S}_3$  (orpiment) has been reported for *Desulfotomaculum auripigmentum* by reduction of both sulfate and arsenate. In a sand environment, a sulfate-reducing bacterium produces crystals of arsenic sulfide under culture of cometabolism (Figure 13.20). The oxidation of arsenite to arsenate proceeds with *Pseudomonas arsenitoxidans*, *Bacillus arsenoxydans*, and *Alkaligenes faecalis*, but only *P. arsenitoxidans* recovers energy from arsenite oxidation. Metabolism of arsenic is not limited to bacteria, but several species of *Penicillium*, *Candida*, *Gliocladium*, and related fungi produce trimethylarsine using S-adenosylmethionine to transfer methyl groups to arsenate or arsenite.

Although considerable interest has been directed to bioremediation of soil and groundwater containing arsenic, the processes are still being developed. Immobilization of arsenic by bacteria with precipitation of insoluble arsenite minerals has not yet been established as useful in part because of the mobilization by bacteria. Plants that hyperaccumulate arsenate have some potential for removal of arsenate from contaminated surface waters, while trees, sunflowers, and other nonhyperaccumulating plants appear useful for phytoremediation of soil with arsenic. Arsenate uptake in plants would be enhanced by uptake activities of mycorrhizae that have a great facility to acquire phosphate from the

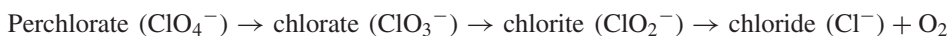


**Figure 13.20.** Large crystal of arsenic sulfide on a sand grain; reduction of arsenate was catalyzed by *Desulfovibrio desulfuricans* (photographs provided by David S. Simonton).

soil. Plants grown in an arsenic environment would extract arsenate from the environment, and plant material would need to be treated as a hazardous waste.

#### 13.9.4 Bioremediation of Perchlorate Sites

One of the most commonly used rocket propellants is ammonium perchlorate, and the release of perchlorate ( $\text{ClO}_4^-$ ) in wastewater has presented an environmental concern. Initially the wastewater was collected in ponds, and after the water was evaporated, the residue was burned. With improper disposing of industrial material, perchlorate became a contaminant in drinking water and soil. Bacteria from sewage sludge were used in stirred-tank bioreactors to remediate sites contaminated with perchlorate by reduction according to the following pathway (Nozawa-Inoue et al. 2005):



Indigenous bacteria in the soil that reduce perchlorate are facultative anaerobes or microaerobes, and most of these organisms are also capable of nitrate reduction. However, perchlorate reduction is not attributed to nitrate reductase, but perchlorate reduction is catalyzed by perchlorate reductase (Chaudhuri et al. 2002). Molecular hydrogen or acetate may be added as electron sources for bacteria in contaminated sites, and the microbial communities that reduce perchlorate *in situ* vary with the electron donor. Bacteria that are capable of perchlorate reduction are broadly distributed in the Alphaproteobacteria, Betaproteobacteria, Gammaproteobacteria, and Epsilonproteobacteria. Most of the soil isolates that reduce perchlorate are in the Betaproteobacteria subclass, and commonly these bacteria are members of *Dechloromonas* or *Dechlorosoma* genera.

#### 13.9.5 Bioremediation of Nitrate Pollution

While nitrate is required for plant growth, nitrate at elevated concentrations is a serious environmental problem. Public health standards for drinking water require that nitrate-*N* concentrations do not exceed 10 ppm. Nitrate pollution of lakes, rivers, and streams may be attributed to fertilizers that are washed from agricultural fields. Eutrophication is a consequence of nitrate-rich lakes, where algal growth can produce dense cell suspensions or surface mats of phototrophs. Nitrate pollution of groundwater or surface water may result from animal feedlots (Figure 13.21). If not properly managed, fecal material from farms where chickens, turkeys, pigs, dairy cows, and other animals are raised may become a problem. Usually, the animal waste is collected in shallow lagoons, where it is removed or processed. If not controlled, nitrate produced by bacterial metabolism of animal waste can migrate through the soil into groundwater. Large flocks of wild birds may contribute to nitrate pollution because fecal material from four or five ducks (Figure 13.22) is comparable to that from a single human. Removal of nitrate from drinking water may be accomplished by use of ion exchange and reverse osmosis, which can be relatively expensive. There has been some interest in using bacteria to remediate nitrate-containing water, and this is relatively difficult if the groundwater contains elevated levels of nitrate. A significant fraction of all bacteria are able to use nitrate as a final electron acceptor with reduction to dinitrogen. This process is denitrification, and is discussed in Section





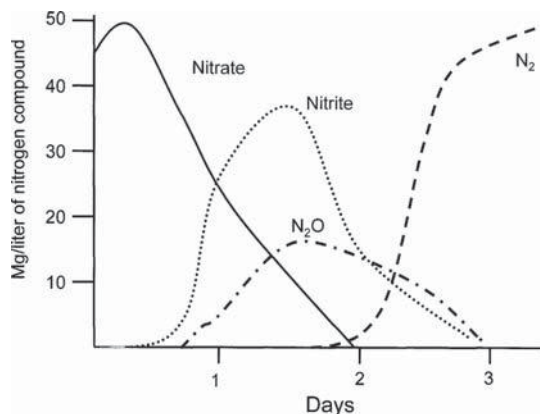
**Figure 13.21.** Aerial view of a feedlot for cattle where confined animals produce a considerable amount of waste; by controlling water runoff and proper management of solid wastes, the stock managers can prevent contamination of subsurface groundwater with nitrate (photograph provided by Kenneth Ingham).



**Figure 13.22.** Wild animals, including birds, can contribute to pollution in the environment (photograph provided by Larry Barton). See insert for color representation.

10.5.4. The succession of detectable nitrogen compounds in denitrification is shown in Figure 13.23.

Using injection wells, ethanol or acetate was added as the electron donor for indigenous microorganisms to accomplish denitrification in groundwater (Weier et al. 1994; Khan and Spalding 2003) or using sawdust in a permeable barrier (Schipper et al. 2005). To reduce biofilm development and prevent clogging of the injectors, 5% hydrogen peroxide and 0.002% NaOCl are added along with the electron donors. The great quantity cell growth clogs the injection well even though 5% hydrogen peroxide and 0.002% NaOCl



**Figure 13.23.** Sequence of nitrogen compounds detected in the environment during denitrification [model is modified from a publication by Paul and Clark (1996)].

were added in an attempt to reduce biofilm development. A supply of acetate or a suitable electron donor would be required to accomplish the reduction of nitrate to  $N_2$ .

### 13.10 SUMMARY

Microorganisms have long been known to be important in decomposing organic compounds added to the environment. Currently there is considerable interest in using microorganisms to mineralize toxic organic compounds. Bioremediation systems are proven effective for use of indigenous bacteria from the environment for the bioremediation of complex organic molecules; however, the bacteria with the appropriate enzymes may be in low abundance, but through appropriate enrichment the desired bacteria can assume sufficient population density to perform the desired catalysis. A few bacterial and fungal oxygenases have a broad range of substrates that can be oxidized, and these are potentially useful for development to degrade recalcitrant molecules. Optimal degradation of organic compounds in nature with bacteria occurs with bacteria growing in coculture or by co-metabolism. Persistence of PAHs or pesticides in the environment is attributed to aqueous insolubility or binding to clay in the environment.

Microorganisms have also been useful in degradation of inorganic compounds and reducing toxicity of metals/metalloids. Many iron-reducing and sulfate-reducing bacteria can use soluble metals or metalloids as the electron acceptors, but the element remains in the environment. Even though some microorganisms are capable of methylating metals, some suggest that this process is not an appropriate bioremediation option. Reactive permeable barriers or large contained bioreactors promote the removal of metals, and an industrial treatment of metals in a zinc refinery has been successfully employed. *In situ* bioremediation is a complex process involving dissimilatory metal-reducing bacteria (DMRB) as well as organisms that can reoxidize the reduced elements or increase concern for toxic activity because metals may be released by DMRB from iron-containing minerals. Through selective addition of electron donors, microorganisms in the environment can slowly detoxifying perchlorate, nitrate, arsenate, or selenate in the environment.

### 13.11 DELVING DEEPER: CRITICAL THINKING QUESTIONS

1. What factors might determine a decision to use bioremediation rather than chemical remediation of a contaminant in the environment?
2. What is biofarming, and when would it be appropriate to use it for remediation of a contaminated environment?
3. Describe the microbial processes in a permeable reactive barrier and indicate when it would be appropriately used.
4. Describe the activities of microorganisms associated with hydrocarbon degradation following an oil spill in a marine environment. What steps can be taken to enhance microbial degradation of oil spill by indigenous microorganisms?
5. What types of microorganism are involved in degradation of PAHs and TNT?
6. Distinguish between oxidative dehalogenation and reductive dehalogenation as may occur in bioremediation of chlorinated organic compounds.
7. What microbial activities would contribute to the reduction of oxidized metal ions? Is there a specific enzyme for each metal that is being reduced by *Desulfovibrio* or *Geobacter*?
8. Design a process for bioremediation of groundwaters containing elevated concentrations of  $\text{Cd}^{2+}$  and  $\text{Zn}^{2+}$  in which binding activities of microorganisms are the central feature.

### BIBLIOGRAPHIC MATERIAL

#### Suggested Reading

- Adriaens P, Vogel TM (1995), Biological treatment of chlorinated organics, in Young LY, Cerniglia CE, eds., *Microbial Transformation and Degradation of Toxic Organic Chemicals*, New York: Wiley-Liss, pp. 435–487.
- Atlas RM, Philp JC (2005), *Bioremediation: Applied Microbial Solutions for Real-World Environmental Cleanup*, Washington, DC: ASM Press.
- Doyle E, Muckian L, Hickey AM, Clipson N (2008), Microbial PAH degradation, *Adv. Appl. Microbiol.* **65**:27–67.
- Gieg LM, Duncan KE, Sufliata JM (2008), Bioenergy production via microbial conversion of residual oil to natural gas, *Appl. Environ. Microbiol.* **74**:3022–3029
- Jørgensen KS (2007), *In situ* bioremediation, *Adv. Appl. Microbiol.* **61**:285–306.
- Nyer EK, Kidd DF, Palmer PL, Crossman TL, Fam S, Jones II FG, Bouettcher G, Suthersan SS (1996), *In situ Technology Treatment*, Boca Raton, FL: Lewis Publishers.
- Roehl KE, Meggyes T, Simon FG, Stewart DJ (2005), *Long-Term Performance of Permeable Reactive Barriers*, Amsterdam: Elsevier.
- Robinson NJ, Whitehall SK, Cavet JS (2001), Microbial metallothioneins, *Adv. Microbial Physiol.* **44**:184–216.
- Rosser SJ, Basran A, Travis ER, French CE, Bruce NC (2001), Microbial transformation of explosives, *Adv. Appl. Microbiol.* **49**:1–36.
- Samanta SK, Singh OV, Jain RK (2002), Polycyclic aromatic hydrocarbons: Environmental pollution and bioremediation, *Trends Biotechnol.* **20**:243–248.

- Volesky B (1990), *Biosorption of Heavy Metals*, Boca Raton, FL: CRC Press.
- Young LY, Cerniglia CE, eds. (1995), *Microbial Transformation and Degradation of Toxic Organic Chemicals*, New York: Wiley-Liss.

### Cited References

- Alexander M (1994), *Biodegradation and Bioremediation*, New York: Academic Press.
- Anderson RT, Vrionis HA, Ortiz-Bernard I, Resch CT, Long PE, Day-vault R, Karp K, Marutzky S, Metzler DR, Peacock A, White DC, Lowe M, Lovley DR (2003), Stimulating the *in situ* activity of *Geobacter* species to remove uranium from the groundwater of a uranium-contaminated aquifer, *Appl. Environ. Microbiol.* **69**:5884–5891.
- Barton LL (2005), *Structural and Functional Relationships in Prokaryotes*, New York: Springer.
- Barton LL, Fauque GD (2009), Biochemistry, physiology and biotechnology of sulfate-reducing bacteria, *Adv. Appl. Microbiol.* **68**:41–98.
- Barton LL, Plunkett RM, Thomson BM (2003), Reduction of metals and nonessential elements by anaerobes, in Ljungdahl LG, Adams MW, Barton LL, Ferry JG, Johnson MJ, eds., *Biochemistry and Physiology of Anaerobic Bacteria*, New York: Springer, pp. 220–235.
- Bedard DL, Quensen III JF (1995), Microbial reductive dechlorination of polychlorinated biphenyls, in Young LY, Cerniglia CE, eds., *Microbial Transformation and Degradation of Toxic Organic Chemicals*, New York: Wiley-Liss, pp. 127–217.
- Bindauer CA, Harrison MD, Robinson AK, Parkinson JA, Bowness PW, Sadler PJ, Robinson NJ (2000), Multiple bacteria encode metallothioneins and SmtA-like zinc fingers, *Molec. Microbiol.* **45**:1421–1432.
- Boonpathy R (2007), Anaerobic metabolism of nitroaromatic compounds and bioremediation of explosives by sulphate-reducing bacteria, in Barton LL, Hamilton WA, eds., *Sulphate-Reducing Bacteria—Environmental and Engineered Systems*, Cambridge, UK: Cambridge University Press, pp. 503–524.
- Boyle AW, Hähblom MM, Young LY (1999), Dehalogenation of lindane ( $\gamma$ -hexachlorocyclohexane) by anaerobic bacteria from marine sediments and by sulfate-reducing bacteria, *FEMS Microbiol Ecol.* **29**:379–387.
- Brierley JA, Goyak GM, Brierley CL (1986), Considerations for commercial use of natural products for metal recovery, in Eccles H, Hunt E, eds., *Immobilization of Ions by Bio-sorption*, Chichester, UK: Ellis Harwood, pp. 105–117.
- Bruschi M, Barton LL, Goulhen F, Plunkett RM (2007), Enzymatic and genomic studies on the reduction of mercury and selected metallic oxyanions by sulphate-reducing bacteria, in Barton LL, Hamilton, WA, eds., *Sulphate-Reducing Bacteria: Environmental and Engineered Systems*, Cambridge, UK: Cambridge University Press, pp. 435–458.
- Cantafio AW, Hagen KD, Lewis GE, Bledsoe TL, Nunan KM, Macy JM (1996), Pilot-scale selenium bioremediation of San Joaquin drainage water with *Thauera selenatis*, *Appl. Environ. Microbiol.* **62**:3298–3303.
- Chakrabarty AM (1976), Plasmids in *Pseudomonas*, *Annu. Rev. Genetics* **10**:7–30.
- Chaudhuri SK, O'Connor SM, Gustavson RL, Achenbach LA, Coates JD (2002), Environmental factors that control microbial perchlorate reduction, *Appl. Environ. Microbiol.* **68**:4425–4430.
- Davis GB, Patterson BM (2003), Developments in permeable reactive barrier technology, in Head IM, Singleton I, Milner MG, eds., *Bioremediation: A Critical Review*, London: Horizon Scientific Press, pp. 205–226.
- Drzyzga O, Gerritse J, Dijk, JA, Ellissen H, Gottschal JC (2001), Coexistence of a sulphate-reducing *Desulfovibrio* species and the dehalorespiring *Desulfitobacterium frappeni* TCE1 in

- defined chemostat cultures growing with various combinations of sulphate and tetrachloroethene, *Environ. Microbiol.* **3**:92–99.
- Ehrlich HL (2002), *Geomicrobiology*, 4th ed. New York: Marcel Dekker.
- Gadd GM (1990), Fungi and yeast for metal accumulation, in Ehrlich HL, Brierley CL, eds., *Microbial Mineral Recovery*, New York: McGraw-Hill, pp. 249–276.
- Gadd GM, Sayer JA (2000), Influence of fungi on the environmental mobility of metals and metalloids, in Lovley DR, ed., *Environmental Microbe-Metal Interactions*, Washington, DC: ASM Press, pp. 237–256.
- Gessey G, Jang L (1990), Extracellular polymers for metal binding, in Ehrlich HL, Brierley CL, eds., *Microbial Mineral Recovery*, New York: McGraw-Hill, pp. 223–248.
- Gold B, Deng H, Bryk R, Vargas D, Eliezer D, Roberts J, Jiang X, Nathan C (2008), Identification of a copper-binding metallothionein in pathogenic mycobacteria, *Nature Chem. Biol.* **4**:609–616.
- Greene B, Darnell DW (1990), Microbial oxygenic photoautotrophs (cyanobacteria and algae) for metal-ion binding, in Ehrlich HL, Brierley CL, eds., *Microbial Mineral Recovery*, New York: McGraw-Hill, pp. 277–303.
- Gross R, Simon J, Kröger A (2001), Periplasmic methacrylate reductase activity in *Wollinella succinogenes*, *Arch. Microbiol.* **176**:310–313.
- Hägglblom MA, Youngster LKG, Somsamak P, Richnow HH (2007), Anaerobic biodegradation of methyl *tert*-butyl ether (MTBE) and related fuel oxygenates, *Adv. Appl. Microbiol.* **62**:1–20.
- Hockin SL, Gadd GM (2007), Bioremediation of metals and metalloids by precipitation and cellular binding, in Barton LL, Hamilton WA, eds., *Sulphate-Reducing Bacteria—Environmental and Engineered Systems*, Cambridge, UK: Cambridge University Press, pp. 405–434.
- Hong Y, Xu M, Guo J, Xu Z, Chen X, Sun G (2007), Respiration and growth of *Shewanella decolorationis* S12 with an azo compound as the sole electron acceptor, *Appl. Environ. Microbiol.* **73**:64–72.
- Keehan KR, Sisk WE (1996), The development of composting for the remediation of explosives-contaminated soils, in Hickey RF, Smith G, eds., *Biotechnology in Industrial Waste Treatment and Bioremediation*, Boca Raton, FL: Lewis Publishers, pp. 69–79.
- Khan IA, Spalding RF (2003), Development of a procedure for sustainable *in situ* denitrification, *Remediation J.* **13**:53–69.
- Lloyd JR (2005), Mechanisms and environmental impact of microbial metal reduction, in Gadd GM, Semple KT, Lappin-Scott HM, eds., *Micro-organisms and Earth Systems—Advances in Geomicrobiology*, Cambridge, UK: University Press, pp. 272–302.
- Lloyd JR, Lovley DR, Macaskie LE (2003), Biotechnological application of metal-reducing microorganisms, *Adv. Appl. Microbiol.* **53**:85–129.
- Lovley DR (1995), Bioremediation of organic and metal contaminants with dissimilatory metal reduction, *J. Industr. Microbiol.* **14**:85–93.
- Madigan MT, Martinko JM, Dunlap PV, Clark DP (2009), *Brock Biology of Microorganisms*, 12th ed., Glenville, IL: Pearson Education.
- Mohn WW, Tiedje JT (1992), Microbial reductive dechlorination, *Microbiol. Rev.* **56**:482–507.
- Nozawa-Inoue M, Show KM, Rolston DE (2005), Reduction of perchlorate and nitrate by microbial communities in vadose soil, *Appl. Environ. Microbiol.* **71**:3928–39934.
- Parales RE, Parales JV, Pelletier DA, Ditty JL (2008), Diversity of microbial toluene degradation pathways, *Adv. Appl. Microbiol.* **64**:1–74.
- Pasczynski A, Pasti-Grisby MB, Goszczynski S, Crawford RI, Crawford DL (1992), Mineralization of sulfonated azo dyes and sulfanilic acid by *Phanerochaete chrysosporium* and *Streptomyces chromofuscus*, *Appl. Environ. Microbiol.* **58**:3598–3604.
- Paul EA, Clark FE (1989), *Soil Microbiology and Biochemistry*, New York: Academic Press.

- Penninckx MJ, Elskens MT (1993), Metabolism and function of glutathione in micro-organisms, *Adv. Microbial Physiol.* **34**:240–302.
- Radwan SS, Sorkhoh NA (1993), Lipids of n-alkane-utilizing microorganisms and their application potential, *Adv. Appl. Microbiol.* **39**:29–90.
- Russ R, Rau J, Stolz A (2000), The function of cytoplasmic flavin reductases in the bacterial reduction of azo dyes, *Appl. Environ. Microbiol.* **66**:1429–1434.
- Santini JM, Sly LI, Schnagl RD, Macy JM (2000), Chemolithoautotrophs arsenite-oxidizing bacterium isolated from a gold mine: Phylogenetic, physiological and preliminary biochemical studies, *Appl. Environ. Microbiol.* **66**:92–97.
- Sarokin D (1988), The toxin release inventory, *Environ. Sci. Technol.* **22**:616–618.
- Scherer MM, Richter S, Valentine RL, Alvarez PJJ (2000), Chemistry and microbiology of permeable reactive barriers for *in situ* groundwater clean up, *Crit. Rev. Microbiol.* **26**:221–264.
- Schipper LA, Barkle GF, Vojvodic-Vukovic M (2005), Maximum rates of nitrate removal in a denitrification wall, *J. Environ. Quality* **34**:1270–1276.
- Schliephake K, Mainwaring DE, Lonergan GT, Jones LK, Baker WL (2000), Transformation and degradation of the diazo dye Chicago Sky Blue by a purified laccase from *Pycnoporus cinnabarinus*, *Enzyme Microbial Technol.* **27**:100–107.
- Schroder I, Rech S, Krafft T, Macy JM (1997), Purification and characterization of the selenate reductase for *Thauera selenatis*, *J. Biol. Chem.* **272**:23765–23768.
- Silver S, Phung LT (1996), Bacterial heavy metal resistance: Newer surprises, *Annu. Rev. Microbiol.* **50**:753–89.
- Staley JT, Gunsalus RP, Lory S, Perry JJ (2007), *Microbial Life*, 2nd ed., Sunderland, MA: Sinauer Associates.
- Stolz A (2001), Basic and applied aspects in the microbial degradation of azo dyes, *Appl. Microbiol. Biotechnol.* **56**:69–80.
- Stolz JF, Basu P, Santini JM, Oremland RS (2006), Arsenic and selenium in microbial metabolism, *Annu. Rev. Microbiol.* **60**:533–559.
- Swoboda-Colberg NG (1995), Chemical contaminants of the environment sources, types and fates of synthetic organic compounds, in Young LY, Cerniglia CE, eds., *Microbial Transformation and Degradation of Toxic Organic Chemicals*, New York: Wiley-Liss, pp. 27–76.
- Weier KL, Doran JW, Mosier AR, Power JF, Peterson TA (1994), Potential for bioremediation of high nitrate irrigation water via denitrification, *J. Environ. Quality* **23**:105–110.
- Widdel F, Musat F, Knittel K, Galushko A (2007), Anaerobic degradation of hydrocarbons with sulphate as electron acceptor, in Barton LL, Hamilton WA, eds., *Sulphate-Reducing Bacteria—Environmental and Engineered Systems*, Cambridge, UK: Cambridge University Press.
- Wise DL, Trantolo DJ, eds. (1994), *Remediation of Hazardous Waste Contaminated Soils*, New York: Marcel Dekker.
- Woodhull PM, Jerger SE (1994), Bioremediation using a commercial slurry-phase biological treatment system. Site-specific application and costs, *Remediation* **4**:353–362.
- Zannoni D, Borsetti F, Harrison JJ, Turner RJ (2007), The bacterial response to the chalcogen metalloids Se and Te, *Adv. Microbial Physiol.* **53**:2–74.
- Zhang Y, Zahir ZA, Frankenberger, Jr WT (2004), Fate of colloidal-particulate elemental selenium in aqueous systems, *J. Environ. Quality* **33**:559–564.

### Internet Sources

<http://www.paques.nl/paques/>: *Bioremediation of zinc*.





---

# INDEX

---

- Abundance of bacterial cells, 148  
Acari, 113, 237, 238. *See also* Mites  
Acetogens, 121  
*Achlya*, 178, 180  
Acidophiles, 30, 308  
    *Acidithiobacillus*, 42, 308, 311  
    *Ferroplasma*, 41–43  
    *Leptospirillum*, 42, 308  
*Acidiphilium*, 308  
*Acidithiobacillus*, 42, 308  
*Acidianus*, 308  
*Acinetobacter*, 308  
Actinobacteria, 106–107, 114, 121, 126,  
    219, 235  
Actinorhizal nodules, 201  
*N*-Acylhomoserine lactone (AHL), 230, 250  
Adherence, 247–248  
Adhesins, 249, 253  
Aeration, 365  
*Aeromonas veronii*, 226  
African dust, 121, 123  
*Agrobacterium*, 209, 210  
Akinete, 72, 83  
Algae, 47, 54–56, 260, 261  
    biomineralization, 303, 306, 314, 317, 319,  
        320, 322–324  
    blooms, 49, 55, 274  
    *Chlorophyta*, 54  
    diversity, 54–56  
    grazing of, 237, 238, 239  
    green, 54  
    metal binding, 303  
    oxygen production, 36, 54  
    red, 54  
    *Rhodophyta*, 54  
Alkaliphiles, 30  
Allelopathy, 211  
Alpha-amylase, 345  
Alphaproteobacteria, 106, 121, 143, 148, 151  
Alveolates, dinoflagelates, 47, 49  
*Alviniconcha*, 231  
Ambrosia beetles, 331  
*Ambrosiella*, 229  
Amensalism, 161–164  
Amitochondriate, 46  
Ammonia monooxygenase, 284  
Ammonification, 282  
Amoeba, 47  
    giant, 68  
Amoebozoa, slime molds, 47, 49–50  
Amphibians, 51, 54  
*Amylosterium*, 226  
*Anabaena*, 62, 95, 184  
Anaerobic oxidation, 370  
Anammox, 223, 262, 264, 282, 284  
Anammoxosomes, 71  
Animal pathogens, 53  
Annelida, 219, 238  
Antagonism, 161, 164  
Antibiotics, 165, 224, 247, 249  
Aquatic habitats, 105–111  
    anti-predation, 106–107  
    freshwater, 107–110  
    lakes, 107–108  
    physico-chemical conditions, 106  
    viruses, 107, 111–112  
    water movement, 106, 108  
*Aquifex*, 36, 125  
*Aquificales*, 36, 265  
*Archaea*, 30, 32–33, 38–45, 219, 220, 227,  
    236, 256, 260, 262–264, 303, 305–308  
    ammonia oxidation, 262  
    *Crenarchaeota*, 39–41  
    *Euryarchaeota*, 39, 40, 42, 45  
    *Bacteria*, 30, 32, 41, 44–45  
    delineation as a separate domain, 38–39

- Archaea (Continued)*  
 diversity, 39–45  
 diversity compared to bacteria, 44–45  
 halophiles, 30, 39, 44  
 hyperthermophiles, 30, 39, 41  
 marine group I, 264  
 methanogens, 39, 42–43, 45  
*Archaeoglobus*, 5  
 Arsenic cycle. *See also* Cycles  
 crystals, 386  
 detoxification, 385–387  
 Arsenite oxidation, 386  
*Arthrobacter*, 290, 308  
*Arthrotrichum*, 212  
 Arthropoda, 219, 238  
*Ascomycota*, 52–54, 229  
*Aspergillus*, 53, 333  
 Assimilatory nitrate reduction, 283  
 Assimilatory sulfate reduction, 285  
 Atmospheric habitats, 121–123  
 diversity, 121  
 Attachment, 248, 249, 250  
 Autoinducers, 230, 250–251  
 Autotrophy, 33  
 Auxin, 203  
*Azoarcus*, 370  
 Azo dyes, decomposition, 378, 380  
*Azolla*, 186, 187  
*Azorhizobium*, 202  
*Azospirillum*, 62, 68, 184  
*Azotobacter*, 3, 72, 282
- Bacillus*, 308  
*Bacillus subtilis*, 175, 251  
*Bacteria*, 30–38  
 abundance in soils, 148  
 adhesins, 253  
 biomineralization, 300–304, 306, 307, 309,  
 312, 314, 315, 317, 320, 323  
 carbonate, 317, 319–324  
 cheese, 266, 268  
 colonization, 252  
 diversity, 33–38  
 interactions with eukaryotes, 217–239  
 luminescent, 230  
 morphology, 30–31  
 nitrogen fixing, 37, 227  
 numbers, 5  
 oral, 246  
 phyla, 33–35, 256–257  
 physiological groups, 116, 148  
 planktonic, 263  
 plaque formation, 249–250  
 supporting plants, 202, 203  
 symbioses with Eukarya, 219  
 thermophiles, 36  
 wine, 266, 267  
 Bacteriocins, 166, 224  
 Bacteriophages, 177, 224, 234  
 Bacteriorhodopsin, 7, 44, 94, 96, 264  
 Bacterioruberin, 45  
*Bacteriovorax*, 165  
 Bacteroidales, 227  
*Bacteroides*, 252  
 Bacteroidetes, 219, 227, 235, 236  
 Barriers, 363  
*Basidiomycota*, 52  
*Bathymodiolus*, 231  
*Batrachochytrium dendrobatidis*, 54  
 Bdelloplast, 174  
*Bdellovibrio*, 161, 164–165  
 Beer, 342  
*Beggiatoa*, 68, 203  
 Beijerinck, Martinus  
 biogeography, 3, 126  
 nitrogen fixation, 195–196  
*Betaproteobacteria*, 107, 126, 148, 229, 230,  
 264  
 Bifidobacteria, 252  
 Binding of metals, 382  
 Bioaccumulation, 381  
 Biobarriers, 363  
 Biocontrol, 211  
 Biodiesel production, 348  
 Bioelectrical activities, 97  
 Bioenergetics, 276  
 Bioenergy, 343–349  
 Biofarming, 363  
 Biofilms, 75, 78–80, 151, 247–249, 251, 254,  
 255  
 succession, 249  
 Biofuels, 344, 348  
 Biogeochemical cycles, 275  
 Biogeography, 126, 128  
 Biological oxygen demand, 350  
 Biologically controlled mineralization, 302,  
 314–315  
 Biologically induced mineralization, 302,  
 314–315  
 Bioluminescence, 230  
 Biomarkers, 8, 153, 154  
 Biomass, 144–145  
 Biomineralization, 299–326, 274  
 biogeochemical zonation, 305–306  
 dissolution versus precipitation, 305–306  
 ferromanganese deposits, 314–317

- geyserites, 313–314
- magnetite, 314–315
- passive versus active, 302
- rock varnish, 315–318
- silica formation, 312–314
- Bioreactors, 362
- Bioremediation, 360, 362, 363, 365, 386
- Biosphere, 2, 296
- Bioventing, 385
- Black smokers, 35, 41
- Botrytis*, 267
- Brevibacterium*, 308
- Brocadia*, 284
- Buchnera*, 222, 226
- Burkholderia*, 174
- Burkholderia capacia*, 175
  
- Cactus, 204
- Calyptogenia*, 231
- Candida*, 266–268
- Candida albicans*, 53
- Candidate phyla, 256
- Candidatus tremblaya princeps*, 229
- Capsules, 303
- Carbon utilization measurement, 145
- Carlsbad Cavern, New Mexico, 51, 123, 310–312
- Carbon cycle, *see* Cycles
- Carbon dioxide fixation, diatoms, 168
- Carbonate, microbial, 305–306, 309, 312, 317, 319–324
  - shells, coccolithophores and foraminifera, 323–324
  - stromatolites, 319–320
  - thrombolites, 320
  - travertines and tufas, 321–323
- Carotenoids, 96, 338
- Carpenter ants, 331
- Caulobacter*, 16, 76, 77
- Caves, 30, 119, 153, 300, 310–312, 317, 354
  - sulfuric acid-driven speleogenesis, 310–312
- Cell
  - attachment, 76
  - communication, 85
  - division, 15
  - shape, 45
  - size, 63, 64, 66, 67
  - wall, 14
- Cell–cell associations, 75–82
- Cell wall, functional groups, 303
- Cellulase, 335
- Cellulose, 330, 332
- Cellulose breakdown, 227, 234, 239
- Cellulosome, 335
- Chaco Canyon National Park, New Mexico, 316
- Chalcopyrite, 308
- Cheese, 266, 268–269, 341
- Chemolithoautotrophy and chemolithotrophs, 32, 33, 41, 91, 226, 228, 230, 254, 265, 290, 305, 307, 315
- Chemoorganotrophy, 39
- Chemotaxis, 18, 68, 69, 85
- Chitin, 337
- Chlorinated organic compounds, 375
- Chlorobi*, 35, 37
- Chlorochromatium aggregatum*, 174
- Chloroflexi, 35–37, 235
- Chlorophylls, 93, 94, 95,
  - Chlorophyta*, 54
- Chloroplasts, 218, 220
- Closed system, 295
- Chromate reduction, 383
- Chondromyces*, 73, 175
- Chromatium*, 175
- Chytridiomycota*, 51–52, 54
- Cilia, 221, 232
- Classification, bacterial/archaeal, 18–19, 25
- Claviceps purpurea*, 53
- Clostridium*, 3, 252, 308, 309
- Clostridium cellobioparum*, 167
- C/N ratios, 352, 364
- Co-limitation, 260, 262
- Coadhesion, 248
- Coaggregation, 248, 249
- Coccolithophores, 319, 323–324
- Cockroaches, 225
- CO<sub>2</sub> fixation reactions, 278
- Cocoa, 342
- Coffee, 342
- Collembola (a.k.a. sprintails), 113, 237, 238
- Collagen, 339, 340
- Collagenase, 340
- Colonization, 208, 249, 251–254, 259
  - recolonization, 253
- Colonization resistance, 225–226
- Colony-forming units, 136
- Comamonas acidovorans*, 176
- Commensalism, 161, 162, 184, 221
- Communities
  - biofilms, 247–248
  - dust, 121–123
  - hot springs, 245, 264–265
  - marine, 263–264
  - wine and cheese, 266–269

- Community diversity, 23  
 Community ecology, 245–246  
 Community fingerprinting, DGGE, 149  
 Community structure, 245, 247, 249, 253–256  
 Comparisons, Archaea and Bacteria, 45  
 Competition, 161–163, 253–256, 258, 259  
   protozoa, 163, 260  
 Composting, 350–352  
 Conidia, bacterial, 72  
 Coniferyl alcohol, 334  
*Cordyceps*, 212  
 Contaminant migration, 364  
 Corrosion, microbially influenced, *see*  
   Microbially influence corrosion  
 Costerton, J. William, 247  
 Cresote, decomposition, 373, 374  
 Crown gall, 203, 209  
 Cryptomonad, 173, 272  
*Cryptothecia rubrocincta*, 55  
 Cueva de Villa Luz, Mexico (a.k.a. Cueva de  
   las Sardinas), 43, 236–237, 310, 311  
 Cultivation of microorganisms, 132–133, 139,  
   142–144, 148  
*Cyanidium caldarium*, 314  
*Cyanobacteria*, 35–37, 72, 220, 235, 238, 259,  
   260, 262, 264, 347, 353, 354  
   biomineralization, 317, 319, 320, 322, 323  
   dinoflagellate symbiosis, 173  
   protozoa symbiosis, 173–174  
   secondary metabolites, 161  
   symbioses, 186, 218, 219, 221  
 Cyanobionts, 168  
*Cyanophora paradoxa*, 173  
 Cyanophycin, 75  
 Cycles  
   arsenic, 277  
   carbon, 276–278, 280, 281  
   hydrogen, 293  
   iron, 277, 287–289  
   manganese, 277, 290  
   mercury, 294, 295  
   nitrogen, 276, 277, 281, 282  
   oxygen, 278, 279  
   phosphorus, 286  
   selenium, 277, 290, 293  
   sulfur, 276, 277, 284  
 Cyst, bacterial, 72  
 Cytoplasmic incompatibility, 224  
 Danube River, Hungary, 109  
*Daptobacter*, 175  
 Darwin, Charles, 11  
*Debaryomyces*, 268  
*Dechloromonas*, 387  
 Decomposition, 254, 275  
   collagen, 339  
   lignin, 333  
   litter, 113  
   organic matter, 280  
   plant matter, 348, 350  
   whale bones, 254  
   wood, 329  
 Deep-sea vents, 36, 120, 264, 265  
 Deep subsurface, 301–302  
   nematodes, 302  
 Deferritobacteres, 235  
 Degradation  
   animal proteins, 254, 337  
   cellulose, 335  
   hemicellulose, 334  
   human impact, 352–354  
   hydrocarbons, 363, 365–373  
   inulin, 336  
   starch, 336  
 Deinococcus–Thermus, 235  
 Deltaproteobacteria, 148  
 Denaturing gradient gel electrophoresis  
   (DGGE), 149  
 Denitrification, 262, 264, 282, 284, 317, 387  
 Desert varnish, 117–118, 315–318  
*Desulfovibrio*, 3, 151, 294, 309, 377, 386  
 Deterioration  
   buildings, 354  
   cultural items, 354  
   monuments, 354  
   paintings, 354  
 Detoxification, 375  
   metals, 381  
   perchlorate, 387  
 Diatoms, 47, 49–50, 79, 126–128, 168, 238,  
   261, 262, 312  
   ecology, 49  
   freshwater, 128  
   walls, opal A, 312–313  
 Diazotrophy (nitrogen fixation), 36–37  
*Dictyostelium*, 49–50  
 Dinoflagellates, 47, 49  
 Dioxins, 372  
 Dioxygenase, toluene, 370  
 Diplomonads, 46  
 Direct counts, 135  
 Dispersal, 248, 254  
 Dissimilatory  
   metal-reducing bacteria, 382  
   nitrate reduction, 284

- sulfate reduction, 284
- Distribution, bacteria, 186
- Disturbance, 252, 255–259
  - intermediate disturbance hypothesis, 257, 259
- Diversity
  - archaea, 39–45
  - algae, 54–56
  - bacteria, 33–38
  - cells, 63
  - fungus, 51–54
  - protists, 46–50
  - resistive structures, 72
  - viruses, 57
- Domains of life, comparison, 32
- Dryadomyces*, 229
- DSS1, 235
- Dunaliella*, 348
  
- East Pacific Rise, 35
- E. coli*, 175–177, 179, 222, 236, 247, 252
- Ecological relationships, 210, 259
- Ecotypes, 19
- Ecovar, 19
- Ectendomycorrhizae, 193, 194
- Ectolithotrophic growth, 352
- Ectomycorrhizae, 189, 190–193
  - nutrient requirements, 91
- El Morro National Monument, New Mexico, 316
- Elastin, 339
- Electron acceptors, electron donors, 92, 125, 305, 306, 309, 310, 315
- Electron microscopy, 139
- Electron transport, 90, 92
- Elemental selenium, 385
- Emerging diseases, 22
- Emiliana huxleyi*, 324
- Enchytraeida, 238
- Endo-1,4- $\beta$ -glucanase, 335
- Endocommensalism, 162
- Endolithic habitats, 118–119
- Endomycorrhizae, 162, 189, 190, 193
  - growth, 193
  - orchids, 195
  - plant hosts, 193
- Endospore, 71, 72
- Endosymbionts, 49
- Endosymbiosis, 11, 218–236
  - bird-microbial, 235–236
  - deep-sea vents, 227–228, 230–233
  - horizontal transmission, 221, 222, 224, 231
  - mealybugs-bacterial, 226, 229–230
  - Osedax*, 226, 227–228, 254
  - polychaete-bacterial, 226, 227–228, 254
  - theory of, 218–221
  - vertical transmission, 221, 229, 230, 231
- Endotoxins, insects, 213
- Energetics, 87, 88, 91
  - methanogens, 43
- Energy flow, 16, 276
- Energy requiring reactions, 278, 279
- Energy yielding reactions, 277
- Enterobacteriaceae*, 252, 308
- Episymbiont, 231
- Epizoites, 162
- Epsilonproteobacteria*, 231
- Epulopiscium*, 37–38
- Ericoid mycorrhizae, 190, 194
- Escherichia coli*, see *E. coli*
- ETBE, 370, 372
- Ethanol production, 345, 346
- Eukarya, 29, 46–56, 249, 250, 253, 256
  - phylogeny, 46
- Eukaryotic cell origin, 218, 220, 230
- Evolution, 30, 36, 38, 45, 48, 49, 56, 124–126, 128, 146, 152, 218, 220, 221, 223, 227, 229–232, 235, 236, 239, 240
- Exocommensalism, 162
- Exo-1,4- $\beta$ -glucanase, 335
- Explosives, biodegradation, 377
- Expert, Dominique, 208–209
- Extracellular polymeric matrix (EPM), 80
- Extrapolymeric substances, 248, 303, 309, 310, 317, 320, 322
- Extremophiles, 30, 39, 41
  
- Feathers, 338
- Fermentation, 90
- Fermented foods, 341
  - beverages, 342
  - milk, 342
- Ferritin, 289
- Ferromanganese deposits, 30
  - nodules, 290
- Ferroplasma*, 41–43, 105
- Fibrobacter*, 219, 234
- Fibrobacteres, 235
- Fibroin, 338
- Filamentous growth, 82
- Firmicutes*, 219, 227, 235, 236
- Fischerella*, 2
- Fish, 28, 37, 38, 49, 110, 230, 237, 238
- Flagella anatomy, 68



- Flavonoids, 197, 198  
 Fluorescent dyes, 136  
 Fluorescent *in situ* hybridization (FISH), 42, 117, 137, 138  
 Food chain, 23, 259  
 Food webs, 237, 259–261  
   marine, 110–111  
   soil, 112–116  
   structure, 260–261  
 Foraminifera, 319, 323–324  
 Fossils, 7, 51  
   biomineralization, 320  
   fuels, 281  
 Frank, Albert Bernard, 189  
*Frankia*, 116, 201  
 Frasassi Gorge caves, Italy, 311  
 Free-radical action, 334  
 Freshwater habitats, 107–110  
 Frustules, 49–50, 312  
 Fruiting-body bacteria, 72  
 Fuel hydrocarbons, 368–372  
 Fungi, 51–54, 113–116, 120–122, 126, 226, 234, 261, 268  
   *Ascomycota*, 52–54  
   *Basidiomycota*, 52  
   biomineralization, 303, 304, 306, 317  
   *Chytridiomycota*, 51–52, 54  
   defining characteristics, 51–52  
   diversity, 51–54  
   *Glomeromycota*, 52, 54  
   grazing of, 237, 238  
   metal binding, 303  
   mutualism, 161, 219, 226, 228–229  
   mycorrhizae, 189–195  
   pathogens, 206–207  
   phylogeny, 51–52  
   promoting plants, 211  
   role in the ecosystem, 51  
   ruminant guts, 234  
   secondary metabolites, 161  
   *Zygomycota*, 52, 54  
 Fusobacteria, 235, 249, 250  
  
*Galdieria sulphuraria*, 314  
*Gallionella*, 300  
*Gammaproteobacteria*, 148, 229–231, 236, 264  
 Gas hydrates, 281  
 Gas vacuoles,  
 Gastrointestinal tract, 252, 253. *See also* Gut,  
   newborn, 252  
 Geesey, Gill, 81  
 Gene fusion, 11  
  
 Genetic engineering, 362  
 Genetic variation, 124  
 Genomes, 67  
*Geobacter*, 97, 290, 383, 314–315  
 Geomicrobiology, *see* Biomineralization  
*Geosiphon*, 176, 177  
 Gibbs free energy, 305  
 Gliding, 69  
 Global regulation, 86, 87, 88  
*Glomeromycota*, 52, 54  
*Glomus*, 184, 194, 211  
 Glucoamylase, 336, 345  
 Glucosidase, 336  
 Glycolysis, 89  
 Grand Prismatic Spring, Yellowstone, USA,  
   109–110  
 Grazing, 176, 236–239,  
 Grazing resistance, 237  
 Great Lakes, North America, 107  
 Great plate count anomaly, 24  
 Great Salt Lake, Utah, 106  
 Green algae, 54  
 Griffin, Dale, 122–123  
 Groundwater habitats, 120  
 Growth, 17  
 Growth-promoting rhizobacteria, 202, 212  
 Guilds, 91  
 Gut communities, 225–227, 235–236  
   arthropod, 37, 43, 225–228, 234  
   bacteria, 224  
   bird, 235–236  
   human, 236  
   mammals, 43, 233–236  
   newborn, 252  
   ruminant, 233–235  
  
 Habitats  
   abiotic factors, 104–105  
   aquatic, 105–111  
   atmospheric, 121–123  
   caves, 119  
   endolithic, 118–119  
   freshwater, 107–110  
   groundwater, 120  
   gut, 225–227, 235–236  
   hot spring, 109–110, 321  
   marine, 106, 110–111, 121  
   rock, 117–121  
   soil, 111–117  
   subsurface, 119–121  
*Haloarcula*, 2  
*Halobacteriales*, 44  
*Halobacterium*, 94

- Halophiles, 30, 39, 44  
*Haloquadratum walsbyi*, 45  
Halorhodopsin, 44, 95, 96  
*Hanseniaspora*, 266  
Hasting, John, 250  
Hartig net, 191, 193  
*Hatena*, 171  
Haustoria, 193  
Hawai'i, lava cave, 300  
Heat tolerance, plants, 211  
*Heliobacteriaceae*, 36  
Hemagglutinins, 224  
Hemicellulose, 330, 332  
Hemolysins, 224  
Herbicides, 376, 377  
Heterocysts, 37, 193  
*Heterorhabditis*, 223  
Heterotrophs, 89–91, 246, 253, 254, 261, 265, 306, 307, 315, 320  
Hoatzin, 235–236  
Horizontal gene transfer, 124, 125–126  
Hormones, plant, 202, 203, 210  
Host-parasite interaction, 22  
Hot springs, 109–110, 126, 245, 264–265, 321  
    Yellowstone National Park, USA, 109–110, 245, 246  
Human mouth bacteria, 246, 249, 250  
Humus, 280, 351  
Hydrobacter, 24  
Hydrocarbons, 307  
    degradation, 363, 365–373  
    polyaromatics, 372–373  
Hydrogel, 247, 248  
Hydrogen-based reactions, 35, 36, 39, 43, 110, 120–121  
Hydrogen cycle, *see* Cycles  
Hydrogen gas production, 227, 234, 236, 346  
Hydrogenosomes, 12, 46–47, 227  
Hydrothermal  
    deep-sea vents, 120, 265  
    terrestrial hot springs, 264–265  
Hyperthermophiles, 30, 41, 64, 109  
    archaea, 41  
    electron donors and acceptors, 41  
Hypolimnion, 107  
  
Ice nucleation bacteria, 205  
*Ignicoccus*, 41, 174  
Infection thread, 197  
Infective juvenile larval stage, 223  
Inhibitors, end products, 167  
Iron cycle, *see* cycles  
Iron-reducing bacteria, 315, 383  
  
Insecticides, 375, 376  
Insects, Bt toxin, 213  
Inulinase, 336  
Interactions, 161–181  
    classification, 161  
    examples, 161  
    types, 161  
Internal membranes, 87  
Interspecies electron transfer, 97  
Interspecies hydrogen transfer, 167, 294  
Intertidal sediments, 253  
Iron oxidizing bacteria  
    *Ferroplasma*, 41–43  
    microbially influenced corrosion, 309  
    siderophores, 304  
Iron reducing bacteria, 121  
  
Kappa factor, 173  
Keratin, 337, 338  
Keystone species, 261  
*Kloeckera*, 266  
*Kluyveromyces*, 333  
  
Laccase, 334  
Lactic acid bacteria, 266, 268  
Lake Baikal, Siberia, 107  
Lake Van, Turkey, 323  
Lakes, 105, 107–108  
Lammarin, 75  
Land farming, 363  
Lateral gene transfer, 201  
Lava caves, 31  
Leaf surface bacteria, 205  
Lechuguilla Cave, New Mexico, 310  
Leeches, 226  
Leghemoglobin, 200  
Lentisphaerae, 235  
*Leptospirillum*, 42, 308  
*Leptothrix*, 82, 290, 303  
*Leuconostoc*, 308  
Lichens, 161, 168–171, 205, 306, 353  
    algal partner, 55  
    carbon dioxide fixation, 169  
    evolution, 169  
    fossils, 169  
    morphology, 169  
    mycorrhizal associations, 53, 54  
    nitrogen fixation, 37, 169  
    physiology, 169  
    pigmentation, 170  
    pollution effects, 169, 170  
    reproduction, 169  
    taxonomy, 169  
    uses, 170

- Lifecycles, 209  
 bacteria, 74, 77  
 fungi, 73
- Lignin, 330, 331, 332
- Ligninase, 334
- Lignin peroxidase, 334
- Lignocellulose, 346
- Lipid granules, 75
- Litter, 113
- Lyngbya*, 55
- Lysobacter*, 165, 175
- Magnetosomes, 68, 70, 71, 289, 315
- Magnetotactic bacteria, 314–315
- Malpigh, Marcelo, 195
- Manganese  
 cycle, *see* Cycles  
 nodule, 291  
 peroxidase, 334  
 precipitation in varnish, 315–316  
 redox bacteria, 309
- Margulis, Lynn, 48, 218–221
- Marine ecosystem, 111, 261–262, 263–265
- Marine habitats, 106, 110–111, 121, 226
- Mariprofundus ferrooxydans*, 35, 36
- Mars analog, 316
- Melanins, 338
- Membrane  
 anammox, 88  
 chemolithotrophs, 88  
 internal, 87  
 nuclear, 88  
 photosynthetic, 88
- mer* operon, 294, 295
- Mercury cycle, *see* Cycles
- Metagenomics, 133, 143, 149–151, 246
- Metal adsorption  
 active, 303–304  
 cell characteristics, 303, 304  
 eukaryotes, 303  
 passive, 303
- Metal reduction, 382, 384
- Metalloid reduction, 384
- Metalloproteases, 224
- Metallosphaera*, 308
- Metallothioneins, 381
- Metazoans, co-occurrence with  
 microorganisms, 258
- Methane, 39, 41, 43–44, 228, 231  
 hydrates, 347  
 oxidation, 366  
 production, 280, 347
- Methanobacteria, 367
- Methanobacterium*, 308
- Methanobrevibacter*, 227, 236
- Methanogenesis, 43, 45, 280
- Methanogens, 39, 42–43, 121, 227, 234, 236
- Methanopyrus*, 5
- Methanosphaera stadtmanae*, 236
- Methanospirillum*, 167
- Methanothermobacter*, 97
- Methylation  
 mercury, 294  
 metalloids, 384  
 metals, 384
- Methylobacterium*, 205, 368
- Metschnikowia*, 266
- Micavibrio aeruginosavorus*, 165, 175
- Micrite, 317
- Microbe-metal interactions, 379, 381–385
- Microbial  
 diversity, 22  
 interactions, 275  
 mats, 30, 31, 247–249, 265
- Microbioally influenced corrosion (MIC),  
 309–310
- Microscopy, 135–139  
 direct counts, 135  
 electron microscopy, 139  
 fluorescent dyes, 136  
 fluorescent *in situ* hybridization (FISH), 137,  
 138  
 total cell counts, 135
- Mid-Atlantic Ridge, 41
- Midges, 237
- Mills, David, 266–268
- Mineralization, 280, 375, 383
- Mines, 301–302  
 nematodes, 302
- Mining  
 biomining, 307–310  
 petroleum recovery, 307–310
- Mites, 113, 237, 238. *See also* Acari
- Mitochondria, 218, 220
- Mitosomes, 46
- Mixed fermentation, 349
- Mono Lake, California, 31, 106, 321, 323
- Monoxygenase, toluene, 370
- Movement, 69, 189
- Mobile Cave, Romania, 153–154, 310
- MTBE, 370, 372
- Mucor*, 178
- Multicellularity, 250
- Mushrooms, 52, 190
- Mutualism, 203, 211, 221–230

- animals, 219, 224–236
- mycorrhizae, 190
- two members, 174
- Wolbachia*, 223–225
- Mycorrhizae, 189–195, 386
- Mycorrhizal fungi, 184, 211
- Mycorrhization helper bacteria, 202
- Myxobacteria, 165, 175
- Myxococcus*, 72, 73, 175
- Myxococcus xanthus*, 249
  
- N*-Acylhomoserine lactone, 230, 250
- Nanoarchaeum equitans*, 41, 66, 174
- Nanobacteria, 65, 66
- Nanowires, 97
- Natural selection, 124, 257
- Nealson, Kenneth, 250
- Nematoda, 54, 113, 212, 219, 223–226, 237, 238
- Nematode-trapping fungi, 212
- Nephroselmis*, 173
- Neutralism, 161, 162
- Niches, 105, 125
- Nitrate bioremediation, 387
- Nitrate reduction, 305, 387
- Nitrification, 282, 283
- Nitrobacter*, 282, 283
- Nitrogen cycle, *see* Cycles
- Nitrogen metabolism, 279
- Nitrogenase, 200
- Nitrogen fixation, 113, 117, 148, 153, 199, 201, 202, 227, 252, 264
  - bacteria, 36–37, 113, 116, 117, 195, 259, 263, 282, 283
  - bacterial-plant symbiosis, 113, 117, 195
  - cyanobacteria, 37, 168, 262, 263
  - legumes, 37
  - lichens, 169–171
  - metabolism, 279
  - nodule formation, 195–201
  - ocean, 264
  - soil, 113, 116
  - spirochaetes, 37
  - termite guts, 37, 227
- Nitrosomonas*, 282, 283
- Nod factors, 197, 201
- Nodules
  - roots, 195, 198–201
  - stems, 202
- Nostoc*, 169, 176
- Nostoc-Geosiphon* association, 176
- Nuclear membrane, 71, 88
- Nutrient cycling
  - nitrogen, 261, 262, 264
  - oceans, 261–262
- Nutrients
  - bioremediation, 363
  - growth, 189, 191, 192, 275
  - reserves, 74–75
  
- Oceanospirillales*, 226, 227
- Oenococcus*, 266
- O’Connell, Michael, 196–197
- Oil spills, 366, 367
- Oligotrophic, 107, 117, 120, 136, 143
- Omic technologies, 24
- Onstott, T. C., 301–302
- Opal A, 313–314
- Orchid mycorrhizae, 190, 195
- Ore formation, 306–307
- Organic pollutants, 374
- Origin of life, 9
- Osedax*, 227–228, 254
- Ostreococcus tauri*, 56
- Oxygen cycle, *see* Cycle
  
- Pace, Norm, 21, 32
- Pacific Ocean, 111
- PAH, *see* Polyaromatic hydrocarbons
- Paleoclimate records, 316
- Paramecium aurelia*, 163
- Parasitism, 161, 163–164, 221–225
  - Arthropoda, 223–224
  - nematodes, 213, 223–224
  - virulence, 224
- Pasteur, Louis, 3
- Pathogenic bacteria, evolution, 173
- Pathogens, 76
  - animals, 53, 54
  - plants, 53, 206, 207, 211
- PCB, *see* Polychlorinated biphenyl
- Pectinase, 333
- Pediococcus*, 266, 268
- Pelagibacter*, 66, 143
- Pelotomaculum*, 97
- Penicillium*, 268
  - spores, 74
- Pentachlorophenol, 372
- Perchlorate, reduction, 387
- Peridibacter*, 165
- Persistent organic pollutants (POP), 374, 375
- Pesticides, 361, 374, 375, 376
- Pests, 211
- Petroleum recovery, 307–309
- Phanerochaete*, 334, 335, 378
- Pheromones, 178

- Phosphatase, 286  
 Phosphonates, 286, 287  
 Phosphorus, 261, 262  
 Phosphorus cycle, *see* Cycles  
*Photobacterium fischeri*, 250  
 Photo response, 96  
*Photorhabdus luminescens*, 223, 224  
 Photosynthesis, 7, 94, 261, 263, 280, 393  
 Photosynthetic membranes, 88  
 Phototrophy and phototrophs, 35–36, 264, 265  
 Phycocyanin, 94  
 Phycoerythrin, 94  
 Phyllosphere, 205  
 Phylogenetic anchor, 150  
 Phylogenetics, 133, 146–148, 283  
 Physiological groups of bacteria, 148  
 Phytase, 287  
 Phytic acid, 287  
 Phytochelins, 381  
 Phytohormones, 199  
 Phytoplankton, 261, 262  
 Picoeukaryote, 56  
 Pili, 77  
*Pilobus*, 96, 97  
 Pioneers in microbial ecology, 4  
 Planctomycetes, 235  
 Plankton, 106, 111, 263–264  
   picoplankton, 260  
 Planktonic cells, 247, 248  
 Plant biomass, composition, 333  
 Plant pathogens, 53  
 Plaque, dental, 249–250  
 Podoviruses, 57  
 Pollution, nitrate, 387  
 Polyaromatic hydrocarbons (PAH), 372–373  
 Polychlorinated biphenyl (PCB), 376  
 Polyphosphate granules, 75, 287  
 Polyploidy, 37–38  
 Population ecology, 124  
 Population growth, 124  
 Porphyrins, 338  
 Precipitation by sulfide, 384  
 Predation, 164, 165, 174, 175, 236–239, 255, 261  
   avoidance, 176  
   food webs, 260  
 Predators, facultative, 175, 247  
 Predatory bacteria, 175, 176  
 Primary production, 261–262, 275  
*Prochlorococcus*, 54  
 Prokaryote, 32  
 Proteases, 339  
*Proteobacteria*, 35–37, 49, 106–107, 114, 121, 126, 148, 218, 219, 235. *See also* specific divisions  
 Proteonomics, 150–152  
 Proteorhodopsin, 264  
 Protists, 46–47, 49–50, 221, 227–228  
   diversity, 46–50  
   roles in the ecosystem, 46  
 Protozoa, 163, 176, 260  
 Prunasine, 211  
*Pseudomonas aeruginosa*, 176  
 Psychrophiles, 30  
*Puccinia*, 53  
*Pyococcus*, 5  
 Pyrite, 308  
*Pyrodictium occultum*, 41, 64  
*Pyrolobus fumarii*, 5, 41  
  
 Quorum sensing, 85, 86, 230, 249–251  
 Quorum sensing interfering substances, 250  
  
 Radiolarians, silica wall formation, 312  
*Rafaella*, 229  
 Random walk, 70  
 Rarefaction curves, 258  
 Red algae, 54  
 Red tide, 49  
 Redfield ratio, 261–262  
 Redox reactions, 304–305  
 Resilience, 256, 259  
 Respiration, 136, 144  
 Respiration index, 144  
*Reticulitermes speratus*, 227  
 Reysenbach, Anna-Louise, 143–144  
 Rhizobia, 116, 117, 163, 176, 195, 199  
*Rhizobium*, 3, 116, 282  
 Rhizodeposition, 188  
 Rhizoplane, 189  
*Rhizopus microsporus*, 174  
 Rhizosphere, 113, 187–189, 202, 209  
   carbon sources, 188  
   interactions, 187–189  
   pH, 189  
   root apical region, 188  
*Rhodophyta*, 54  
 Rhodopsin, 264  
 Ribozyme, 10  
*Rickettsia*, 12  
*Riftia pachyptila*, 226, 230–231  
*Rikenella*, 226  
 Rio Grande, New Mexico, 55, 109, 352  
 Rivers and streams, 105, 108–109, 119, 237, 238

- Rock habitats, 117–121  
 Rock varnish, 117–118, 315–318  
 Root  
   associations, 195  
   regions, 188  
   activities, 211  
 Rumen, 225, 233–234, 236  
 Ruminants, 225, 226, 233–234  
*Ruminococcus*, 234
- Saccharomyces*, 266, 267, 268  
*Saccharomyces cerevisiae*, 54, 266  
 Sampling strategies, 134  
 San Francisco Bay, CA, 44  
 SAR202, SAR324, SAR406, SAR86, 264  
 Selenite reduction, 383  
 Selenium cycle. *See also* Cycles  
   detoxification, 385  
   metabolism, 292  
 Sensory system, 83, 84  
 Sewage treatment, 349  
 Sexual interactions, 176  
 Shannon index, 257, 258  
*Shewanella putrefaciens*, 314–315  
 Silica deposition vesicle, 312  
 Simpson index, 257  
 Sheath-containing bacteria, 79, 303  
*Shewanella*, 76, 97, 290, 383  
 Sick building syndrome, 353  
 Siderophores, 289, 304  
 Silica microbial structures, 49  
   formation in diatoms, radiolarians,  
     sponges, 312  
 Silk, 338, 339, 340  
 Sinapyl alcohol, 334  
 Siphoviruses, 57  
 Sites  
   Crypt, Matera, Italy, 354  
   Eagle Nest Lake, NM, 274  
   Geology Museum, Nanning, China, 291  
   Lascaux Cave, France, 354  
   Mayan stone, Mexico, 354  
   Mosques, Erzurum, Turkey, 354  
   Rio Grande River, NM, 352
- Size  
   amoeba, 68  
   fungi, 68  
 S-layer, 14, 303  
 Slime layer, 303  
 Slime molds, 47, 49–50  
 Smut fungi, 53  
 Sociality, evolution, 221
- Soda Dam, NM, 50, 323  
 Sogin, Mitch, 21, 48  
 Soils, 111–117, 239  
   ammonia oxidation, 262  
   bacterial abundance, 116, 148  
   components, 114, 115  
   diversity, 246, 257  
   fatigue, 211  
   food web, 112–116  
   grazing, 238  
   habitats, 111–117  
   horizons, 111–112, 114–115  
   microbial abundance, 113–114, 116  
   microbial food webs, 112–117  
   Midwestern United States, 112  
   mycorrhizae, 116  
   nitrogen fixing bacteria, 116  
   nutrient flow, 113, 239  
   permeability, 112  
   sickness, 211  
   Yucatan, 112
- Solemya*, 231–232  
 Sonoran Desert, Southwest, US, 204  
 Soybean nodules, 200  
 Soy sauce, 342  
 Species co-occurrence, 258  
 Species concept, 18  
   bacterial/archaeal, 256  
 Species diversity, 256–258  
   indices, 257–258  
*Sphaerotilis*, 82  
*Shingomonas*, 205  
 Spicular geysers, 313  
 Spiderwebs, 339, 340  
 Spirochaetes, 69, 70, 219–221, 227,  
   228, 235  
 Sponges, silica wall formation, 313  
 Spores, 17, 85, 97  
 Sporulation, 71–74  
 Square “bacteria” (archaeon), 45  
 Squid, symbioses, 226, 230  
 Stability, 255–256  
 Stable isotopes, 117, 152–154  
*Stachybotrys*, 353  
*Staphylococcus aureus*, 251  
 Stetter, Karl, 174  
*Stigmatella*, 73, 175  
 Stramenopiles, diatoms, 47, 49, 238  
*Streptococcus*, 249–251, 268  
*Streptomyces*, 72, 334, 379  
 Storage materials, 74–75  
 Stromatolites, 319–320  
*Stygiolobus*, 308



- Subsurface habitats, 119–121  
 metabolic reactions, 121  
 radiolysis of water, 121
- Succession, 249, 253–254, 269
- Sulfate reducing bacteria, 121, 255, 309, 317, 320
- Sulfide, 33, 41, 42, 120, 121, 154, 226, 228, 230, 231, 232, 384
- Suflita, Joseph, 343
- Sulfobacillus*, 308
- Sulfolobus*, 126
- Sulfur, *see* Cycles
- Sulfur metabolism, 279, 285, 310–311
- Sulfuric acid-driven speleogenesis, 310–312
- Surface-to-volume ratio, 67
- Swimming, 69, 70
- Symbiogenesis, 218
- Symbiosis, 218–236. *See also* Endosymbiosis  
 animal, 223–236  
 associations, 186–187  
 bacteria, 37, 197  
 beetles–fungi, 226, 228–229  
 benefits, 221, 223  
 cactus, 204  
 cockroaches, 225  
 cyanobacteria, 168, 173  
 definition, 65, 168, 173, 174  
 diatoms, 168  
 dual, 66  
 establishing, 176  
 fungi, 174, 178, 219, 226, 228–229, 234  
 fungi–bacteria, 174  
 genomics, 221, 225, 236  
 gut, 224, 225, 227, 228, 233–236  
 host immune response, 222, 224  
 host reproduction, 224  
 human–bacterial/archaeal, 236  
 legumes, 195–201  
 lichens, 169–173  
 nitrogen fixing bacteria, 227  
 pathogenetic mechanisms, 223  
 primary, 222, 223, 229, 230  
 protists, 221, 227, 228  
 protozoa–bacteria, 173–174  
 ruminants, 226, 233–235  
 secondary, 222–223, 229  
 squid–bacterial, 226, 230  
 termites, 226–228  
 three partners, 211  
*Vibrio fischeri*, 226, 230
- Symbiosis motility, 227
- Symbiosomes, 200
- Synechococcus*, 168, 319
- Synergistes*, 227, 234
- Synthesis gas, 343
- Syntrophic communities, 375
- Syntrophism, 43, 167, 294
- Syntrophomonas*, 294
- Syntrophobacter*, 167
- Syntrophus aciditrophicus*, 168
- Syntrophomonas*, 294
- TAME, 370, 372
- Tar, decomposition, 373
- TCA cycle, 90
- Tea, 342
- Tebo, Brad, 291, 292
- Terceira, Azores, Portugal, 31
- Terminal electron acceptors, 305
- Termite Groups 1, 2, and 3, 227, 228
- Termites, 225–228, 234
- Terrabacteria, 24
- Tetrazolium, 137, 146
- Textile dyes, decomposition, 378
- Thallus, 170
- Thauera*, 370, 385
- Thermoactinomyces, 335
- Thermocline, 107
- Thermocrinis ruber*, 265
- Thermonospora*, 334
- Thermophiles, 5–6, 30, 36, 41, 351
- Thermoproteus*, 5
- Thermatoga*, 125
- Thiobacillus*, 311
- Thiodendron*, 220
- Thiomargarita*, 67
- Thrombolites, 320
- Ti-plasmid, 209, 210
- TM7, 235
- TOL pathway, 369
- Toluene, degradation, 368
- Total cell counts, 135
- Toxic organic compounds, 361
- Toxin, *Bacillus thuringiensis*, 213
- Transcriptomics, 151
- Travertine, 321–323
- Treponema*, 227
- Tree of life, 19
- Trichodesmium*, 262–263
- Trichonympha agilis*, 37
- Tufa, 321–323
- Ultramicroscopic bacteria (UMB), 65
- Ultraviolet radiation, 124

- Universal ancestor, 11  
Uranium (VI) reduction, 383
- Vampirococcus*, 175  
van Leeuwenhoek, Anton, 3, 23  
Varnish, rock, 117–118, 315–318  
Vents, deep-sea, 36  
Vents, hot, 41  
Vents, deep-sea hydrothermal, 120  
Verrucomicrobia, 219, 235  
Vesicular-arbuscular mycorrhizae, *see*  
    endomycorrhizae  
*Vibrio fischeri*, 226, 230  
Vibrionaceae, 124–125  
Virulence, 224  
Viruses, 56–57, 224, 255, 260  
    abundance, 57  
    bacterial species diversity, 139  
    bacteriophages, 57, 177, 224, 234  
    diversity, 57  
    ecology, 57  
    evolution, 139  
    genome size, 56  
    lysogenic, 56–57  
    lytic, 56–57  
    marine, 57  
    myoviruses, 57  
    roles, 57  
    soil ecology, 57  
    survival, 224
- Waiotapu geothermal region, New Zealand,  
    313–314  
Walsby's square "bacterium", 30, 44–45  
Wasps, 226  
Wetland, 352  
Whale falls, 227–228, 254  
White rot fungi, 331, 334, 373, 375  
*Wigglesworthia glossinidia*, 222  
Wine, 266–268, 342  
Winogradsky, Sergei, 3, 23, 32–33  
Woese, Carl, 21, 33, 38, 42, 133  
*Wolbachia*, 223, 224–225  
Woods Hole Marine Biological Laboratory,  
    MA, 43  
Wool, 338
- Xanthomonas*, 308  
Xenobiotics, degradation, 373  
*Xenorhabdus*, 226  
Xylanase, 334
- Yeasts, 266, 267, 268  
*Yersinia pestis*, 247  
Young, Lily, 371–372
- Zetaproteobacteria*, 35, 36  
ZoBell, Claude, 247  
Zooxanthellae, 49  
*Zymomonas*, 308, 309  
*Zygomycota*, 52, 54



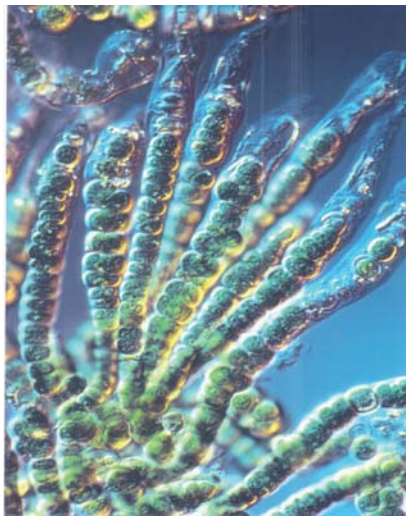


Figure 1.1A



Figure 1.3



Figure 1.4



Figure 2.2

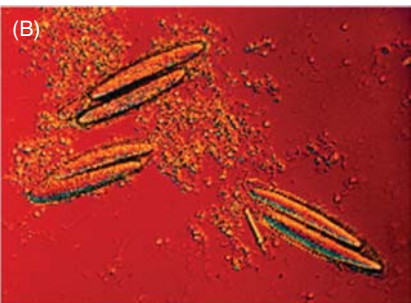
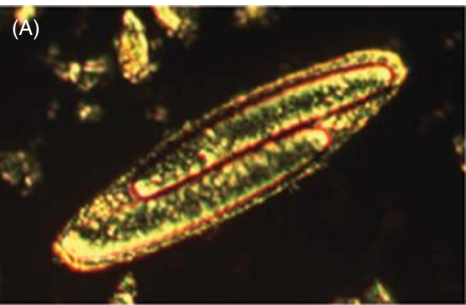


Figure 2.7

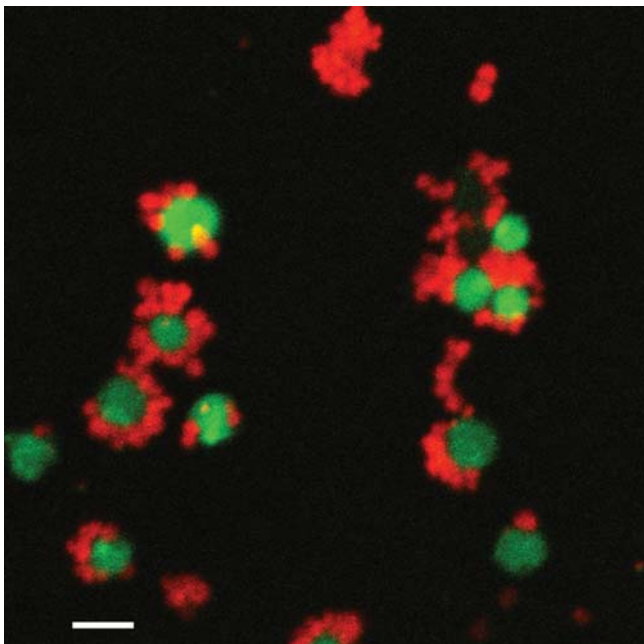


Figure 2.9





Figure 2.11



Figure 2.19

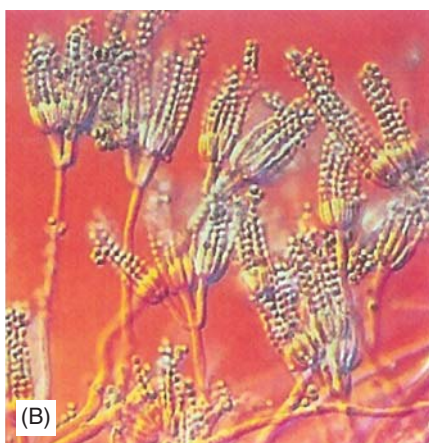


Figure 3.11

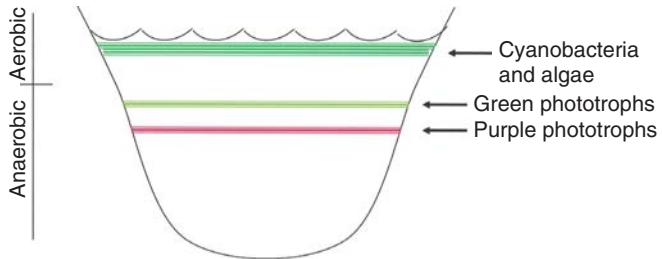


Figure 3.28

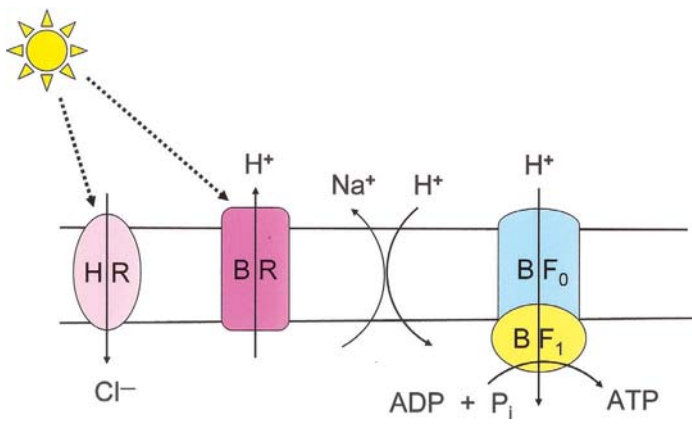


Figure 3.29



Figure 4.1



Figure 4.4

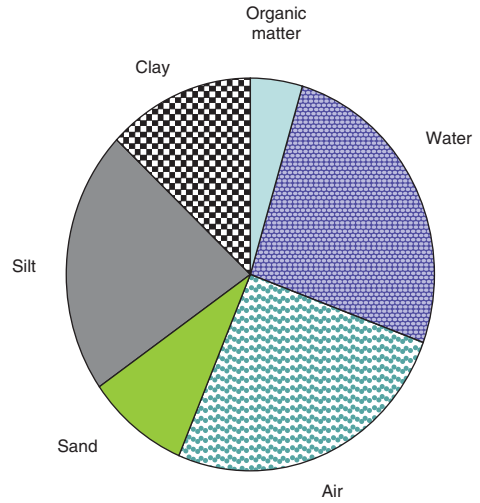
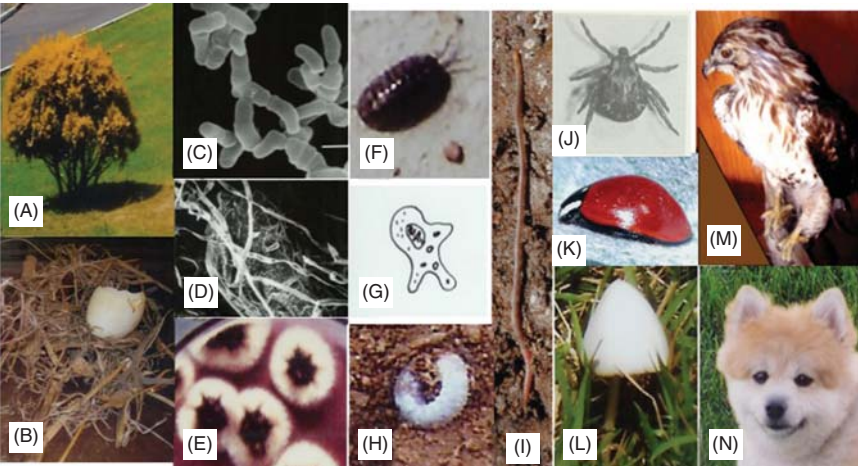


Figure 4.9



1<sup>st</sup> Level  
Photo-systems

2<sup>nd</sup> Level  
Decomposers  
Mutualists  
Root feeders

3<sup>rd</sup> Level  
Shredders  
Grazers  
Predators

4<sup>th</sup> Level  
Higher level  
predator  
Decomposers

5<sup>th</sup> Level  
Highest  
level  
predators

Figure 4.10



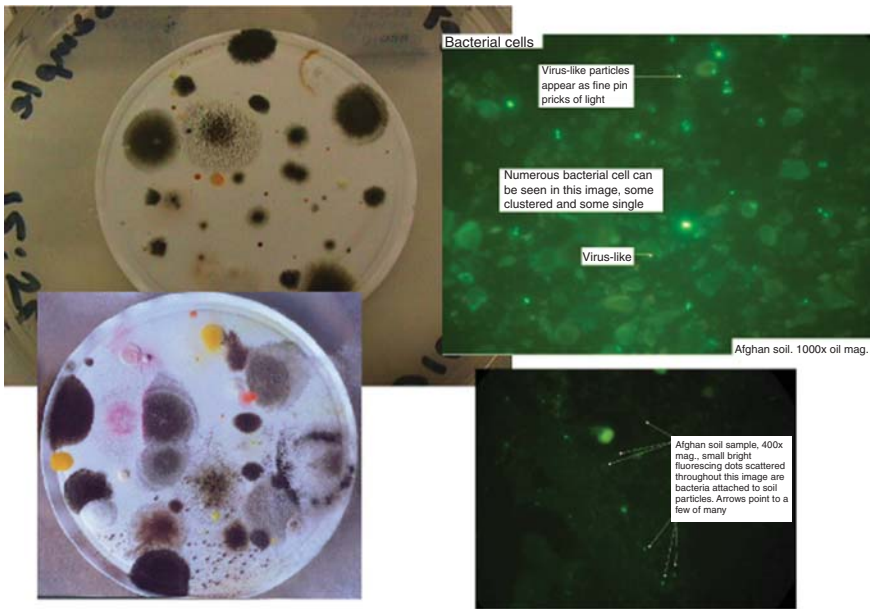


Figure 4.14

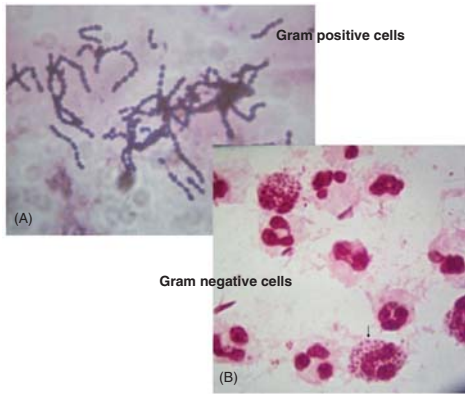


Figure 5.3

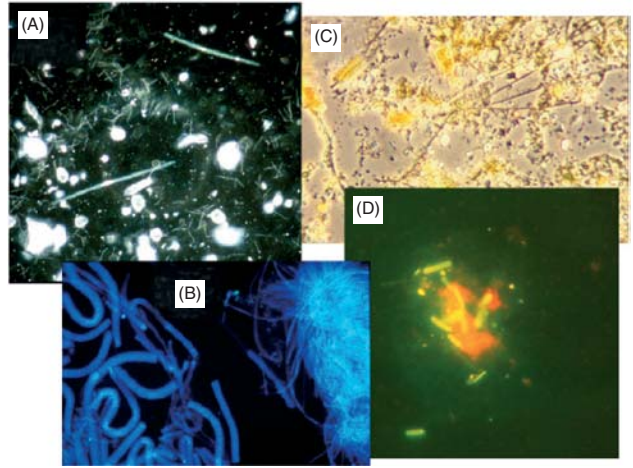


Figure 5.4



Figure 5.5

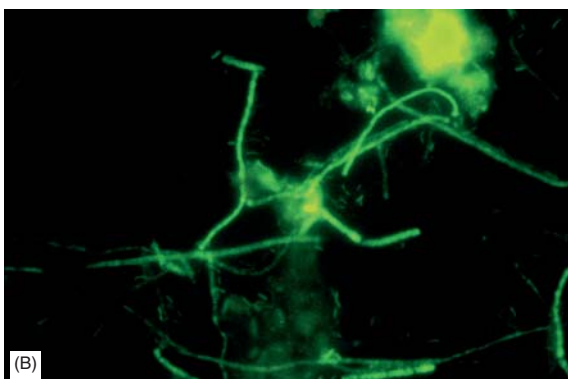
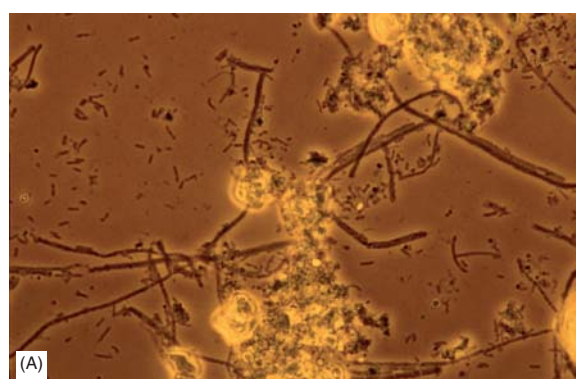


Figure 5.6

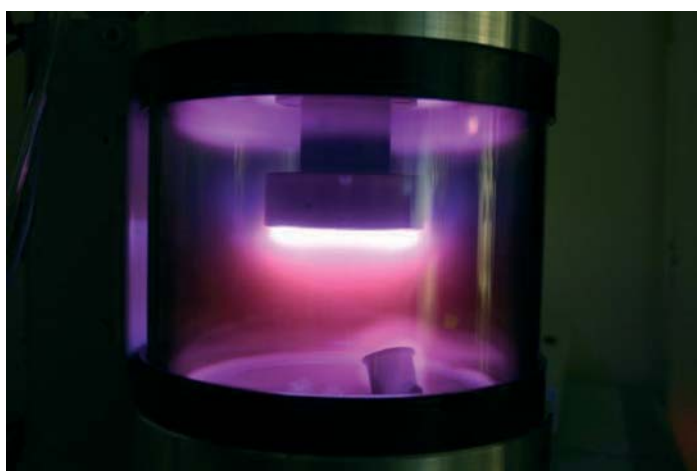


Figure 5.10

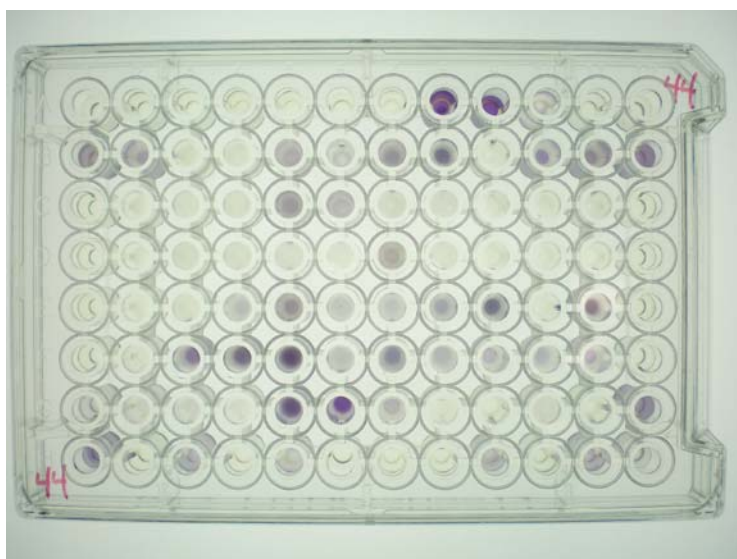


Figure 5.13

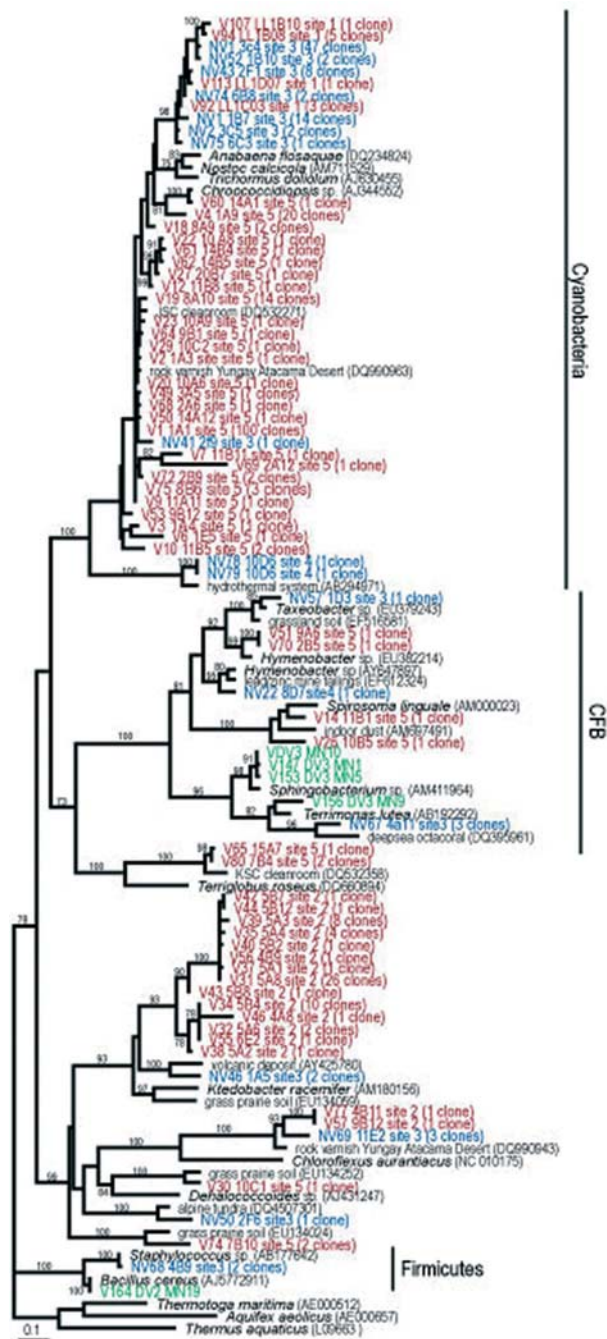


Figure 6.5



Figure 6.6



Figure 6.7

Figure 5.14



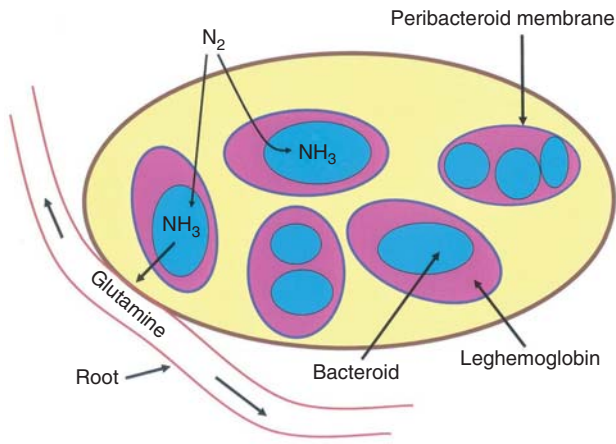


Figure 7.17



Figure 8.1

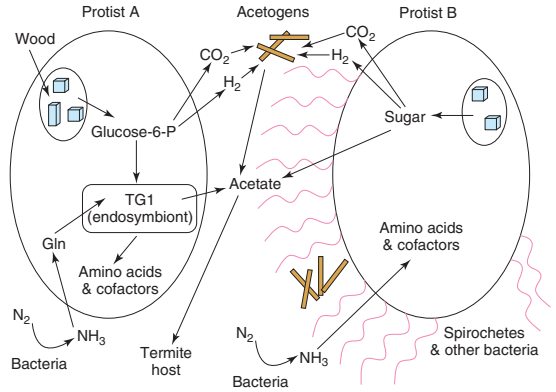


Figure 8.4

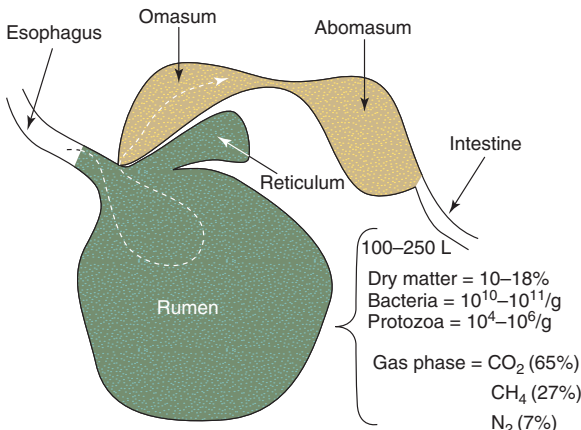


Figure 8.9



Figure 9.2

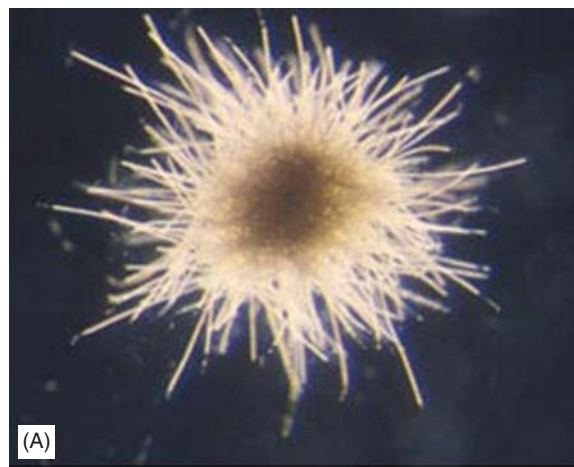


Figure 9.12

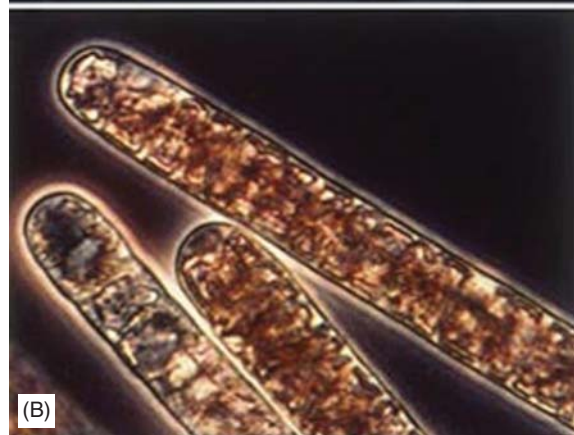


Figure 9.13

Figure 9.9

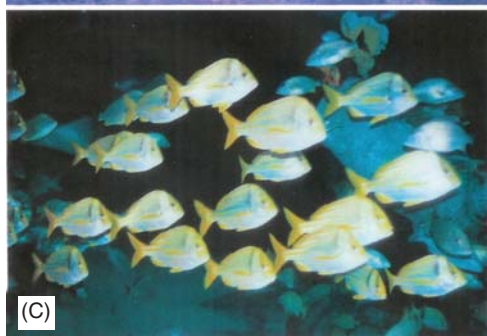
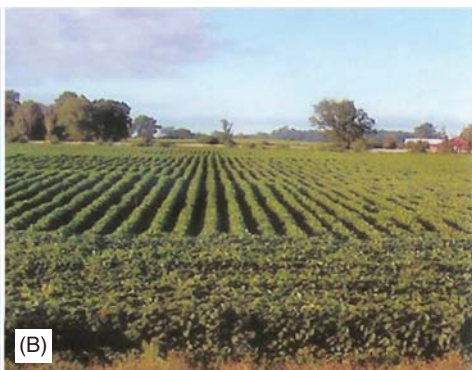


Figure 10.1





Figure 10.17

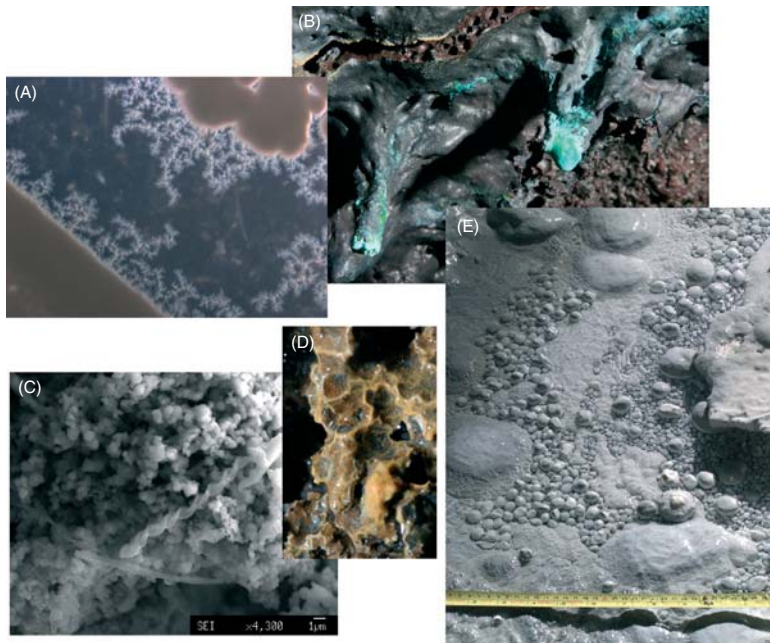


Figure 11.1



Figure 11.5



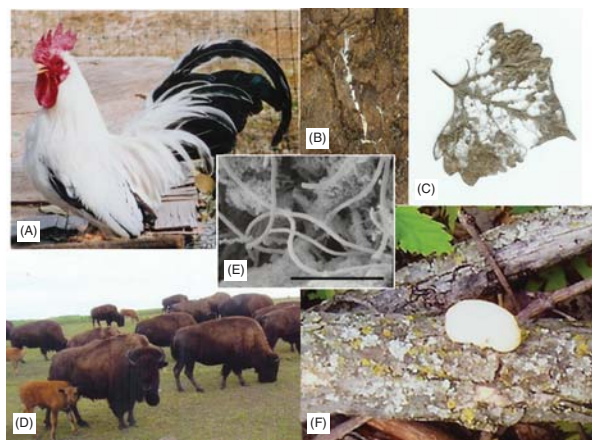


Figure 12.1



Figure 12.3

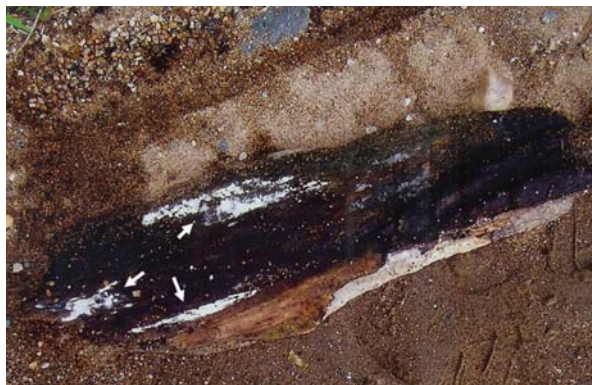


Figure 12.4

Figure 11.12



Figure 12.11

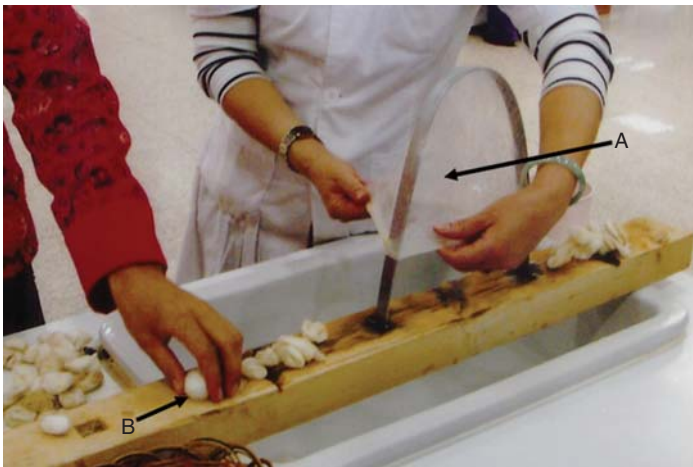


Figure 12.12



Figure 12.17





Figure 12.21



Figure 13.9



Figure 13.22